

## Teljesítménynyilatkozat száma: DOP\_IK\_ETA-17-0261\_v4\_HU

### 1. A terméktípus egyértelmű azonosító kódja:

Schöck Isokorb® beton nyomólapokkal

### 2. Felhasználás célja:

Teherhordó hőszigetelő elemek vasbeton szerkezeti elemek hőtechnikai elválasztásához

### 3. Gyártó:

Schöck Bauteile GmbH, Schöckstraße 1, 76534 Baden-Baden

### 4. Rendszer(ek) a teljesítmény állandóságának értékelésére és ellenőrzésére:

System 1+

### 5. Műszaki értékelés:

Európai értékelő dokumentum/harmonizált szabvány/Nemzeti szabvány:

EAD 050001-00-0301, kiadva: 2018. február

Európai műszaki értékelés/engedély:

ETA-17/0261, kiállítva 2022.09.07. napján

Műszaki értékelést végző szerv/Engedélyező intézmény:

Deutsches Institut für Bautechnik (DIBt), Kolonnenstr. 30B, 10829 Berlin

Bejelentett szerv/Külsős felügyeleti szerv:

Versuchsanstalt für Stahl, Holz und Stein, Universität Karlsruhe (TH), 76128 Karlsruhe: NB 0769

### 6. A nyilatkozatban szereplő teljesítmény(ek):

| Lényeges jellemzők                                 | Teljesítmény   |
|--|--|
| <b>Teherbírás</b>                                  |  |
| $f_{yd}$ ; $Z_{Rd}$                                | lásd C1. függelék: C.1. táblázat, C.2. táblázat  |
| $V_{Rd}$ ( $Z_{V,Rd}$ )                            | lásd C1. függelék: C.1. táblázat, C.3. táblázat  |
| $D_{Rd}$   | lásd C.2. és C.3. függelék: C.4. táblázat, C.5. táblázat, C.6. táblázat, C.7. táblázat       |
| <b>Az építőanyagok tűzzel szembeni viselkedése</b> |  |
| Osztály az EN 13501-1 szabvány szerint             | lásd A5. függelék  |
| Betonacél  | A1 osztály   |
| Rozsdamentes acél                                  | A1 osztály   |
| Beton a nyomott alátámasztáshoz                    | A1 osztály   |
| Hőszigetelő hézag                                  | E osztály  |
| Tűzvédelmi anyag                                   | A1 osztály   |
| HTE műanyag zsalu                                  | NPD  |
| Tűz esetén habosodó építőanyag                     | E osztály  |
| Műanyag sínek                                      | NPD  |
| <b>Tűzállóság</b>                                  |  |
| Tűzállóság időtartama (R teherbírás)               | lásd C4., C5. és C6. függelék: C.8. táblázat, C.9. táblázat<br>Kivétel a 28–32. ábra szerint |
| <b>Lépéshang-szigetelés</b>                        |  |
| NPD  |  |
| <b>Hőátbocsátási ellenállás</b>                    |  |
| $R_{eq, TI}$                                       | lásd C8. és C9. függelék: C.11. táblázat   |

---

**7. Megfelelő műszaki dokumentáció és/vagy egyedi műszaki dokumentáció:**

A Schöck Isokorb® beton nyomólapokkal európai műszaki értékeléshez kapcsolódó műszaki dokumentáció – a DIBt-nél leadásra került.

A fent azonosított termék teljesítménye megfelel a bejelentett teljesítményeknek. A 305/2011/EU rendeletnek megfelelően e teljesítménynyilatkozat kiadásáért kizárólag a fent meghatározott gyártó a felelős. A gyártó nevében és részéről aláíró személy:

Baden-Baden, 01.10.2022

(hely, dátum)

A handwritten signature in black ink, appearing to read 'i.v. N. Puttendörfer'.

(Dr.-Ing. Niklas Puttendörfer, Head of R&D)

Approval body for construction products  
and types of construction

Bautechnisches Prüfamt

An institution established by the Federal and  
Laender Governments



## European Technical Assessment

ETA-17/0261  
of 9 February 2021

English translation prepared by DIBt - Original version in German language

### General Part

Technical Assessment Body issuing the  
European Technical Assessment:

Deutsches Institut für Bautechnik

Trade name of the construction product

Schöck Isokorb® with concrete compression elements

Product family  
to which the construction product belongs

Load bearing thermal insulation elements which form a  
thermal break between balconies and internal floors

Manufacturer

Schöck Bauteile GmbH  
Vimbucher Straße 2  
76534 Baden-Baden  
DEUTSCHLAND

Manufacturing plant

Schöck Bauteile GmbH, Vimbucher Straße 2  
76534 Baden-Baden, Germany

Schöck Bauteile GmbH, Nordsternstraße 61  
45329 Essen, Germany

Schöck Bauteile Ges.m.b.H., Handwerkstraße 2  
4055 Pucking, Austria

Schöck Sp. z o.o., ul. Przejazdowa 99,  
43-100 Tychy, Poland

This European Technical Assessment  
contains

42 pages including 4 annexes which form an integral part  
of this assessment

This European Technical Assessment is  
issued in accordance with Regulation (EU)  
No 305/2011, on the basis of

EAD 050001-00-0301

This version replaces

ETA-17/0261 issued on 11 September 2017

The European Technical Assessment is issued by the Technical Assessment Body in its official language. Translations of this European Technical Assessment in other languages shall fully correspond to the original issued document and shall be identified as such.

Communication of this European Technical Assessment, including transmission by electronic means, shall be in full. However, partial reproduction may only be made with the written consent of the issuing Technical Assessment Body. Any partial reproduction shall be identified as such.

This European Technical Assessment may be withdrawn by the issuing Technical Assessment Body, in particular pursuant to information by the Commission in accordance with Article 25(3) of Regulation (EU) No 305/2011.

**Specific part**

**1 Technical description of the product**

The Schöck Isokorb® with concrete compression elements is used as load-bearing thermal insulation element to connect reinforced concrete slabs.

The product description is given in Annex A.

The characteristic material values, dimensions and tolerances of the Schöck Isokorb® with concrete compression elements not indicated in Annexes A1 to A5 shall correspond to the respective values laid down in the technical documentation<sup>[1]</sup> of this European Technical Assessment.

**2 Specification of the intended use in accordance with the applicable European Assessment Document**

The performances given in Section 3 are only valid if the Schöck Isokorb® with concrete compression elements is used in compliance with the specifications and conditions given in Annex B.

The verifications and assessment methods on which this European Technical Assessment is based lead to the assumption of a working life of the Schöck Isokorb® with concrete compression elements of at least 50 years. The indications given on the working life cannot be interpreted as a guarantee given by the producer, but are to be regarded only as a means for choosing the right products in relation to the expected economically reasonable working life of the works.

**3 Performance of the product and references to the methods used for its assessment**

**3.1 Mechanical resistance and stability (BWR 1)**

| Essential characteristic | Performance       |
|--------------------------|-------------------|
| Load bearing capacity    | See Annex C1 – C3 |

**3.2 Safety in case of fire (BWR 2)**

| Essential characteristic      | Performance       |
|-------------------------------|-------------------|
| Reaction to fire of materials | See Annex A5      |
| Resistance to fire            | See Annex C4 – C6 |

**3.3 Protection against noise (BWR 5)**

| Essential characteristic | Performance             |
|--------------------------|-------------------------|
| Impact sound insulation  | No performance assessed |

**3.4 Energy economy and heat retention (BWR 6)**

| Essential characteristic | Performance       |
|--------------------------|-------------------|
| Thermal resistance       | See Annex C8 – C9 |

<sup>[1]</sup> The technical documentation of this European technical approval is deposited at the Deutsches Institut für Bautechnik and, as far as relevant for the tasks of the approved bodies involved in the attestation of conformity procedure, is handed over to the approved bodies.

English translation prepared by DIBt

**4 Assessment and verification of constancy of performance (AVCP) system applied, with reference to its legal base**

In accordance with EAD No. 050001-00-0301, the applicable European legal act is: [1997/0597/EC].

The systems to be applied is: 1+

**5 Technical details necessary for the implementation of the AVCP system, as provided for in the applicable EAD**

Technical details necessary for the implementation of the AVCP system are laid down in the control plan deposited with Deutsches Institut für Bautechnik.

The following standards are referred to in this European Technical Assessment:

- EN 206:2013+A1:2016 Concrete: Specification, performance, production and conformity
- EN 1992–1–1:2004/A1:2014 Eurocode 2: Design of concrete structures – Part 1-1: General design rules and rules for buildings
- EN 1993-1-1:2005 + AC:2009 Eurocode 3: Design of steel structures – Part 1-1: General design rules and rules for buildings
- EN 1993-1-4:2006 + A1:2015 Eurocode 3: Design of steel structures – Part 1-4: General rules – Supplementary rules for stainless
- EN 10088-1:2014 Stainless steels – Part 1: List of stainless steels
- EN 12664:2001 Thermal performance of building materials and products – Determination of thermal resistance by means of guarded hot plate and heat flow meter methods – Dry and moist products of medium and low thermal resistance
- EN 13163:2012+A2:2016 Thermal insulation products for buildings – Factory made expanded polystyrene (EPS) products – Specification
- EN 13245-1:2010 Plastics – Unplasticized poly(vinyl chloride) (PVC-U) profiles for building applications – Part 1: Designation of PVC-U profiles
- EN 13245-2:2008 + AC:2009 Plastics – Unplasticized poly(vinyl chloride) (PVC-U) profiles for building applications – Part 2: PVC-U profiles and PVC-UE profiles for internal and external wall and ceiling finishes
- EN 13501-1:2018 Fire classification of construction products and building elements – Part 1: Classification using data from reaction to fire tests
- EN ISO 6946:2017 Building components and building elements – Thermal resistance and thermal transmittance – Calculation method (ISO 6946:2017)
- EN ISO 10211:2017 Thermal bridges in building construction – Heat flows and surface temperatures – Detailed calculations (ISO 10211:2017)

English translation prepared by DIBt

- EN ISO 10456:2007+AC:2009 Building materials and products – Hygrothermal properties – Tabulated design values and procedures for determining declared and design thermal values (ISO 10456:2007 + Cor. 1:2009)
- EN ISO 17660-1:2006 Welding – Welding of reinforcing steel – Part 1: Load-bearing welded joints (ISO 17660-1:2006)
- EN ISO 17855-1:2014 Plastics – Polyethylene (PE) moulding and extrusion materials - Part 1: Designation system and basis for specifications (ISO 17855-1:2014)
- EN ISO 17855-2:2016 Plastics - Polyethylene (PE) moulding and extrusion materials – Part 2: Preparation of test specimens and determination of properties (ISO 17855-2:2016)

Issued in Berlin on 9 February 2021 by Deutsches Institut für Bautechnik

Dipl.-Ing. Beatrix Wittstock  
Head of Section

*beglaubigt:*  
Kisan

## A.1 Type overview

- Type K/K-F:

Tension and compression elements to transfer bending moments as well as tilted bars passing through the insulation layer to transfer shear forces

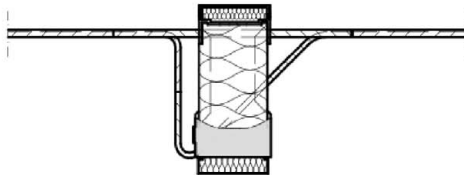

Fig. 1: Schöck Isokorb® type K

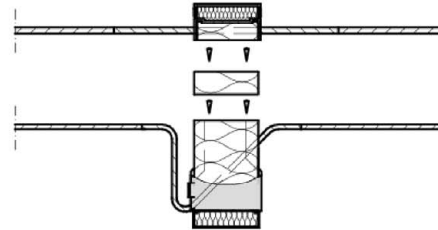

Fig. 2: Schöck Isokorb® type K-F  
(Variation in several parts)

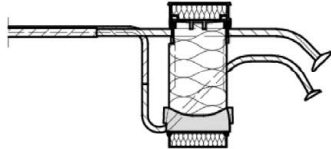

Fig. 3: Schöck Isokorb®  
type K-O for connection to  
walls or slabs made of  
reinforced concrete with or  
without height offset

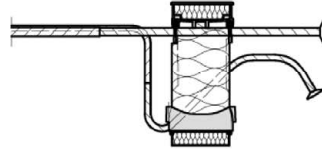

Fig. 4: Schöck Isokorb®  
type K-U for connection to  
walls or slabs made of  
reinforced concrete with  
height offset

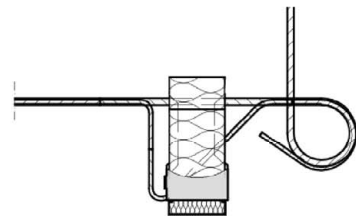

Fig. 5: Schöck Isokorb®  
type K-HV for connection to  
slabs made of reinforced  
concrete with height offset

- Type Q: inclined bars and compression elements in the insulation layer exclusively to transfer shear forces

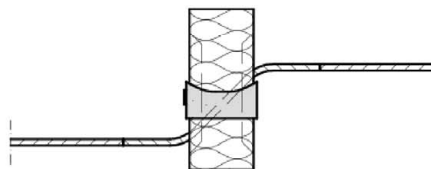

Fig. 6: Schöck Isokorb® type Q

Compression bearing (CCE) variants (Annex A2): HTE Modul, HTE30 or HTE20

### Schöck Isokorb® with concrete compression elements

**Product description**  
Type overview

Annex A1



### Concrete compression bearings HTE Modul and HTE30

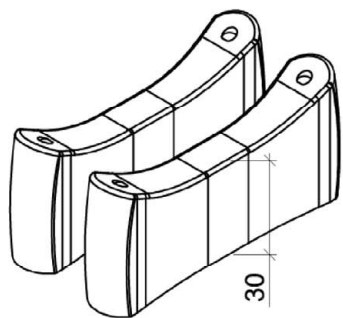

Fig. 7: Insulation thickness 80 mm

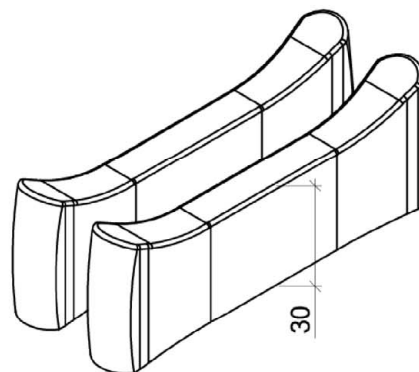

Fig. 8: Insulation thickness 120 mm

### Concrete compression bearing HTE20

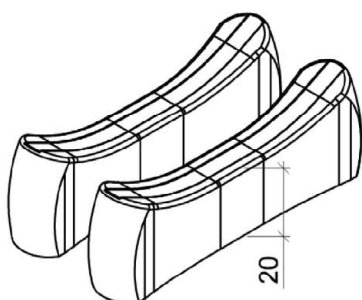

Fig. 9: Insulation thickness 80 mm

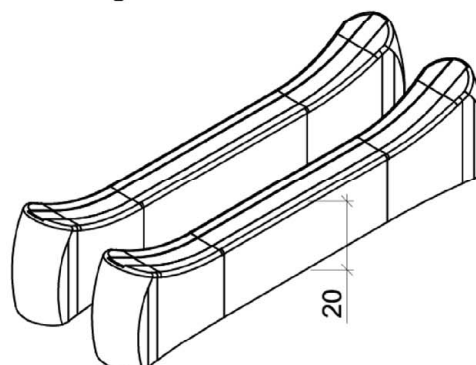

Fig. 10: Insulation thickness 120 mm

#### Schöck Isokorb® with concrete compression elements

##### Product description

Type overview  
Concrete compression bearing variants (CCE), Insulation thickness 80 - 120 mm

Annex A2

## A.2 Dimensions and positioning of the bars and compression elements in the area of the insulation joint

In the insulation joint (80 or 120 mm), tensile and shear force bars consist of stainless reinforcing round steel or stainless steel bars over a length of at least 10 cm within the connected concrete components. Reinforcing steel is welded to the end of these bars.

### Tension bars:

- Diameter:  $\varnothing \leq 20 \text{ mm}$   
stepped nominal diameter in accordance with Annex A4
- Number per meter:  $n \geq 4/m$
- axial distance:  $\leq 300 \text{ mm}$ , on average  $\leq 250 \text{ mm}$

### Shear force bars:

- Number per meter  $n \geq 4/m$
- Diameter:
  - o type Q:  $\varnothing \leq 14 \text{ mm}$
  - o Placement between the individual elements of the compression bearing pairs (type K, K-F):  $\varnothing \leq 8 \text{ mm}$
- inclination in the insulation layer: Usually  $\alpha = 45^\circ$  for an insulation thickness of 80 mm,  $\alpha = 35^\circ$  for an insulation thickness of 120 mm
- axial distance of the bars:  $\leq 300 \text{ mm}$ , on average  $\leq 250 \text{ mm}$
- concrete-free area: Bars must not have any curvature
- diameter of bending block around the compression element: In accordance with Annex B5, D6, D8, D9 and in compliance with the rules of EN 1992-1-1
- Starting point of the inner curvature:  $\geq 2 \varnothing$  von inside the concrete

### Concrete compression bearing (CCE):

- Number per meter:  $n \geq 4/m$
- Clear spacing:  $\leq 250 \text{ mm}$
- Minimum number per component to be connected  $n \geq 4$

## Schöck Isokorb® with concrete compression elements

Product description  
Dimensions

Annex A3

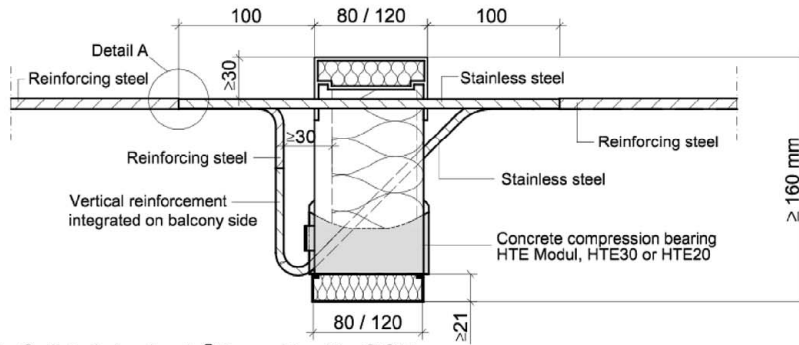

Fig. 11: Schöck Isokorb® type K with CCE

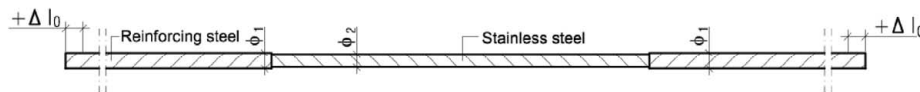

Fig. 12: Tension bar (type K) with diameter combination

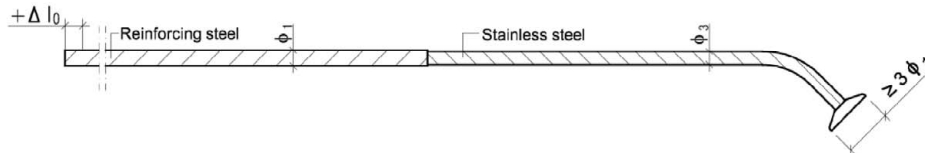

Fig. 13: Tension bar (type K-O) with diameter combination

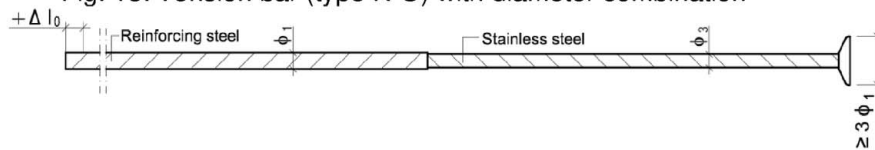

Fig. 14: Tension bar (type K-U) with diameter combination

Table A.1: Diameter combinations and additions to the overlap length

| Graduated tensile bars<br>$\varnothing_1 - \varnothing_2 - \varnothing_1$ | Reinforcing steel<br>$\varnothing_1$ (mm)<br>$R_{p0,2}$ (N/mm <sup>2</sup> ) | Stainless steel<br>$\varnothing_2$ (mm)<br>$R_{p0,2}$ (N/mm <sup>2</sup> ) | $\Delta l_0$ (mm) |
|---|--|--|-------------------|
| 8 - 6,5 - 8   | 8<br>500   | 6,5<br>800   | 20                |
| 8 - 7 - 8   | 8<br>500   | 7<br>700   | 13                |
| 10 - 8 - 10   | 10<br>500  | 8<br>700 / (820 optional)  | 20                |
| 12 - 9,5 - 12   | 12<br>500  | 9,5<br>820   | 20                |
| 12 - 10 - 12  | 12<br>500  | 10<br>700  | 17                |
| 12 - 11 - 12  | 12<br>500  | 11<br>700  | 9                 |
| 14 - 12 - 14  | 14<br>500  | 12<br>700  | 14                |

Material specification: see Section A.3

**Schöck Isokorb® with concrete compression elements**

**Product description**  
Dimensions

Annex A4

### A.3 Materials

The following materials must be used:

|   |   |
|---|---|
| Reinforcing steel:                      | B500B, class A1 according to EN 13501-1   |
| Stainless steel:                        | B500 NR or stainless steel round bars (S355, S460, S690) with corrosion resistance class III according to EN 1993-1-4, class A1 according to EN 13501-1 |
| Concrete compression bearing (CCE):     | High-performance fine-grained concrete, class A1 according to EN 13501-1  |
| Insulation joint:                       | Polystyrene rigid foam (EPS) according to EN 13163, class E as per EN 13501-1   |
| Fire protection material:               | Moisture repellent, weather-resistant and UV-resistant panels, class A1 according to EN 13501-1   |
| Plastic formwork CCE:                   | PE-HD plastic according to EN ISO 17855-1 and EN ISO 17855-2, performance according to EN 13501-1 is not determined                                     |
| Material that foams up in case of fire: | Halogen-free, three-dimensional foaming building material on graphite basis with foaming factor min. 14; class E according to EN 13501-1                |
| Plastic rail:                           | PVC-U according to EN 13245-1 and EN 13245-2, performance according to EN 13501-1 is not determined   |

**Schöck Isokorb® with concrete compression elements**

**Product description**  
Materials

Annex A5

## B.1 Intended use

- Static or quasi-static action loads
- Minimum concrete strength class of the reinforced concrete components to be connected made of normal strength concrete according to EN 206: C20/25, for external components C25/30
- For the connection of 16 cm to 50 cm thick reinforced concrete slabs

### B.1.1 Design

The provisions of EN 1992-1-1 in connection with EN 1993-1-1 and in accordance to Annex D shall apply.

- The connected slab shall be divided by joints (arranged in accordance with section B.2.1)
- Structural verification of the further transmission of the transferred forces shall be provided
- The deviations from the strain of a structurally identical slab without an insulation joint are limited to the joint area and the connecting edges through compliance with the provisions of this European technical assessment
- The undistributed strain may then be assumed to exist at a distance  $h$  from the joint edge
- Variable moments and shear forces along a connected edge shall be considered in the structural analysis
- Strain on the slab connections due to local twisting moments (torques) shall be excluded
- Small normal forces due to imposed deformation in the girder bars (at the end of the line supports, e.g. beside free edges or expansion joints) shall be neglected in the calculation, normal constraining forces in the direction of the bars of the slab connections shall be excluded (see Annex B2 for example)
- Connected components: ratio height/ width  $\leq 1/3$ , if no special verification is performed for the transfer of the transverse tensile stresses

## B.2 Installation requirements

### B.2.1 Centre and joint distances

- Tensile and compression members, shear force bars (The provisions according to section D.1.2.3):

$$5 \text{ cm} \leq s_1 \leq \frac{1}{2} \cdot s_{2,\max}$$

where:

$s_1$  center distance from the free edge or the expansion joint

$s_{2,\max}$  permissible maximum distance between the bars

- External reinforced concrete components: expansion joints shall be placed in a right angle to the insulation layer (see Annex B2)
- Joint distance: Table B.1

## Schöck Isokorb® with concrete compression elements

Intended use  
Installation requirements

Annex B1

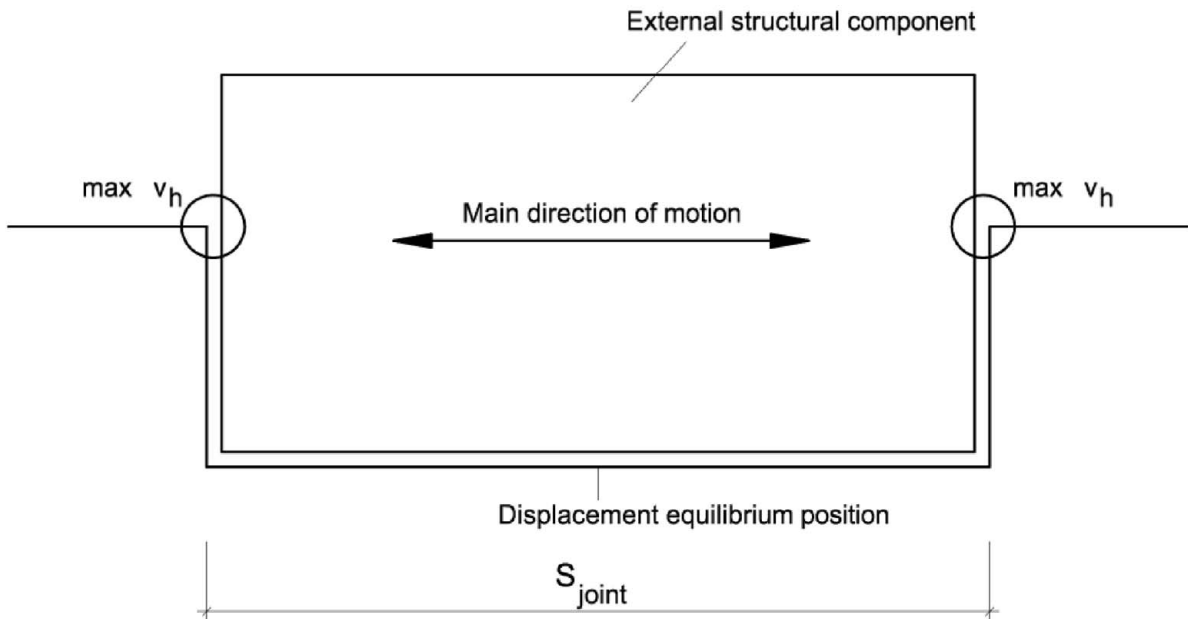

Fig. 15 Installation situation with support on opposite edges

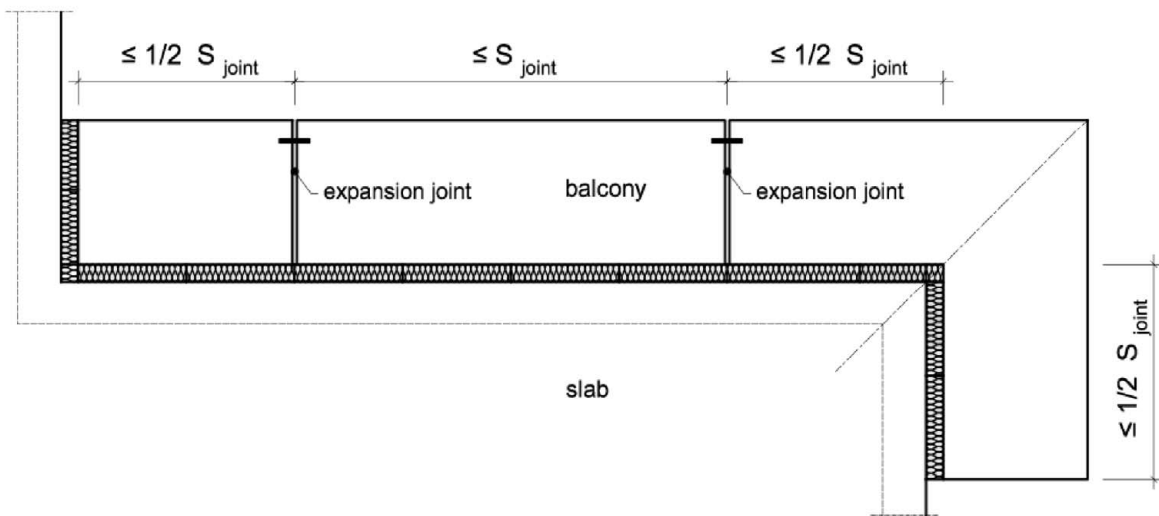

Fig. 16: Installation situation with expansion joint

**Schöck Isokorb® with concrete compression elements**

**Intended use**  
Installation Determination  
Representation of installation situation - insulation thickness 80 - 120 mm

Annex B2

Table B.1: Permitted joint spacing in [m]

| Thickness of the insulation joint [mm] | Bar diameter in the joint [mm] |      |      |      |      |      |      |
|--|--------------------------------|------|------|------|------|------|------|
|  | ≤ 9,5                          | 10   | 11   | 12   | 14   | 16   | 20   |
| 80                                     | 13,5                           | 13,0 | 12,2 | 11,7 | 10,1 | 9,2  | 8,0  |
| 120                                    | 23,0                           | 21,7 | 20,6 | 19,8 | 17,0 | 15,5 | 13,5 |

## B.2.2 Structural design

The minimum concrete cover in accordance with EN 1992-1-1 shall be observed. This applies to tensile bars, the shear reinforcement or existing installation reinforcement. The reinforcement of the concrete structures connected to the load bearing thermal insulation elements shall be extended to the insulation layer in consideration of the required concrete cover in accordance with EN 1992-1-1.

The transverse bars of the upper connection reinforcement shall generally lie on the outside on the longitudinal bars of the slab connections. In the case of bars with a nominal diameter  $\varnothing < 16$  mm an exception may be made if the following conditions are respected:

- The installation of the shear force bars directly underneath the longitudinal bars of the slab connection is possible
- The installation is monitored, e.g. by the construction engineer
- The necessary installation steps shall be described in the installation manual (see Annex B4)

The front surface of the components to be connected shall receive edge reinforcement in accordance with EN 1992-1-1, section 9.3.1.4. Edge reinforcement e.g. in the form of stirrups with at least  $\varnothing \geq 6$  mm,  $s \leq 25$  cm and 2 longitudinal bars each with  $\varnothing \geq 8$  mm shall be positioned on the front surface of the connected slabs parallel to the insulation joint. Including of vertical legs of the shear force bars for Isokorb® types K and K-F (see Annexes B5 and B6) as well as lattice girders with a maximum distance of 100 mm from the insulation joint in accordance with Annex B7 Fig. 27 shall be permitted.

Edge reinforcement on the component sides running parallel to the load-bearing thermal insulation elements should be installed as follows:

- Moments and shear forces are transferred:
  - o Shall overlap the tensile bars
- Uplift shear forces can also be transferred:
  - o Shall overlap the tensile and compression bars
- Exclusively shear forces are transferred:
  - o The required tensile reinforcement shall not be graded around the load-bearing thermal insulation element
  - o The tensile reinforcement shall be anchored in the compression zone on the frontal side with hooks
  - o Alternatively: stirrups at every shear force bar

Subsequent bending of the bars of the load-bearing thermal insulation element is not permissible.

**Schöck Isokorb® with concrete compression elements**

**Intended use**  
Installation requirements

Annex B3

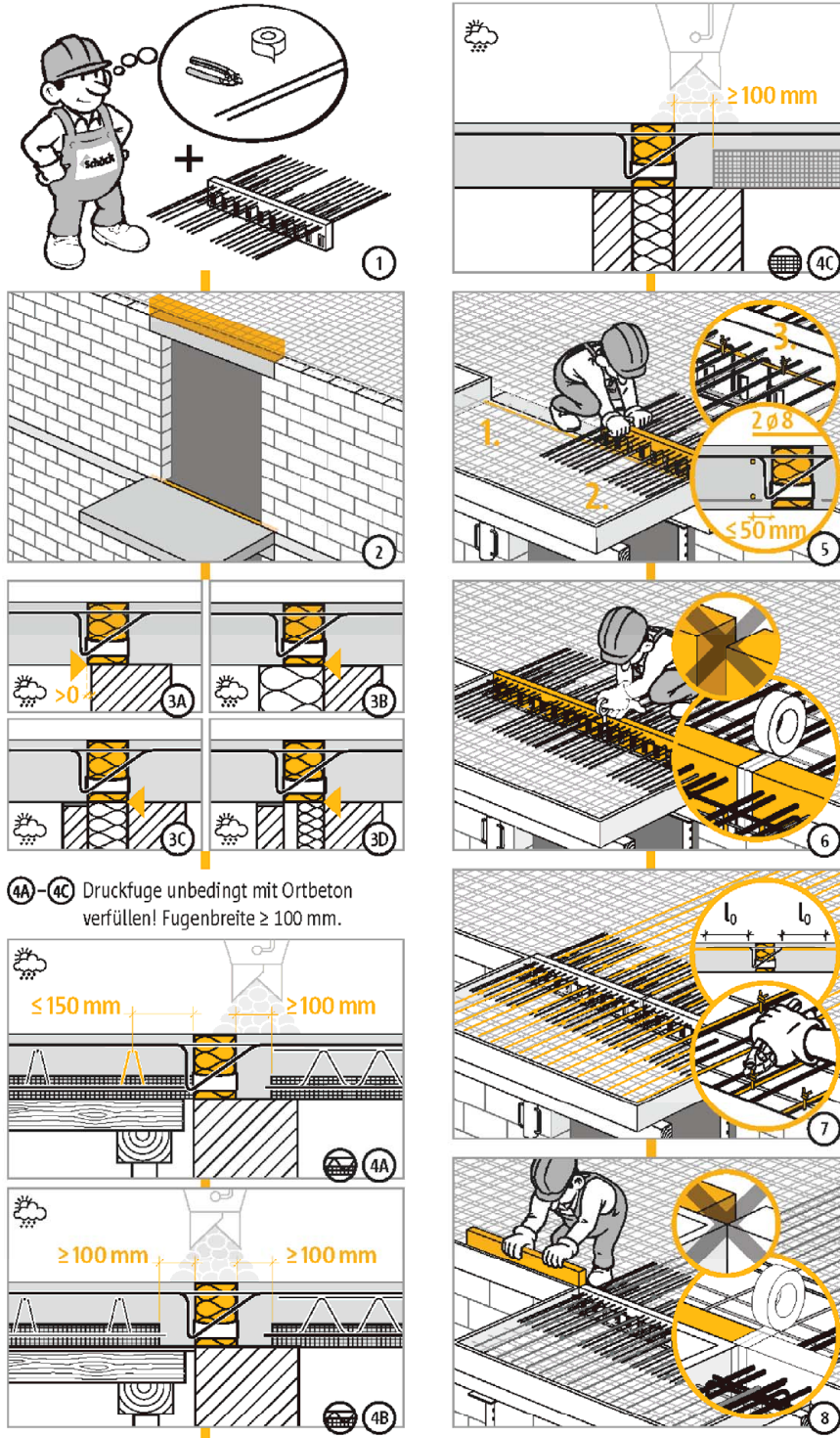

4A-4C Druckfuge unbedingt mit Ortbeton  
verfüllen! Fugenbreite  $\geq 100$  mm.

**Schöck Isokorb® with concrete compression elements**

**Intended use**  
Installation manual Type K

Annex B4



Schöck Isokorb® Type K and K-F

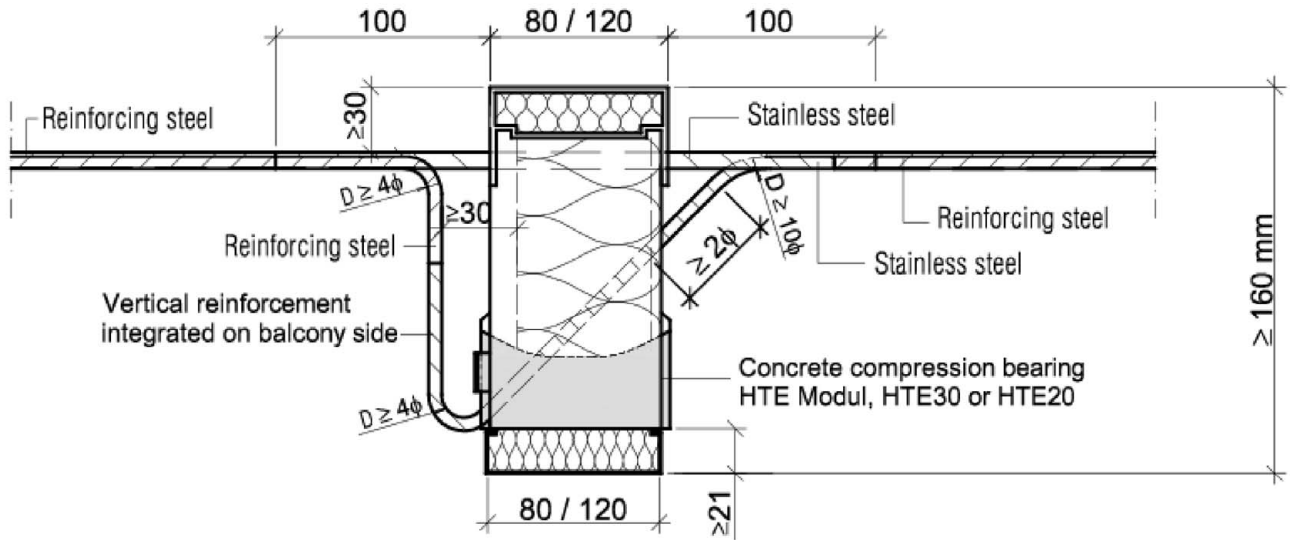

Fig. 17: Schöck Isokorb® type K with CCE

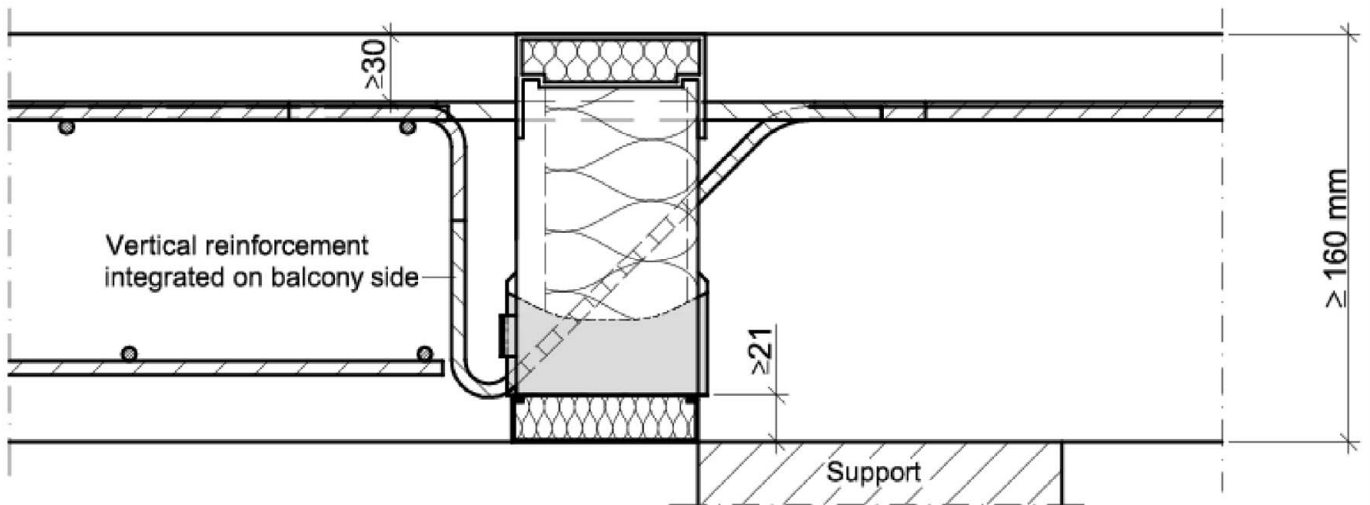

Fig. 18: Schöck Isokorb® type K with CCE in installed condition

**Schöck Isokorb® with concrete compression elements**

**Intended use**  
Installation Determination  
Type K and K-F with CCE - Insulation thickness 80 - 120mm

Annex B5

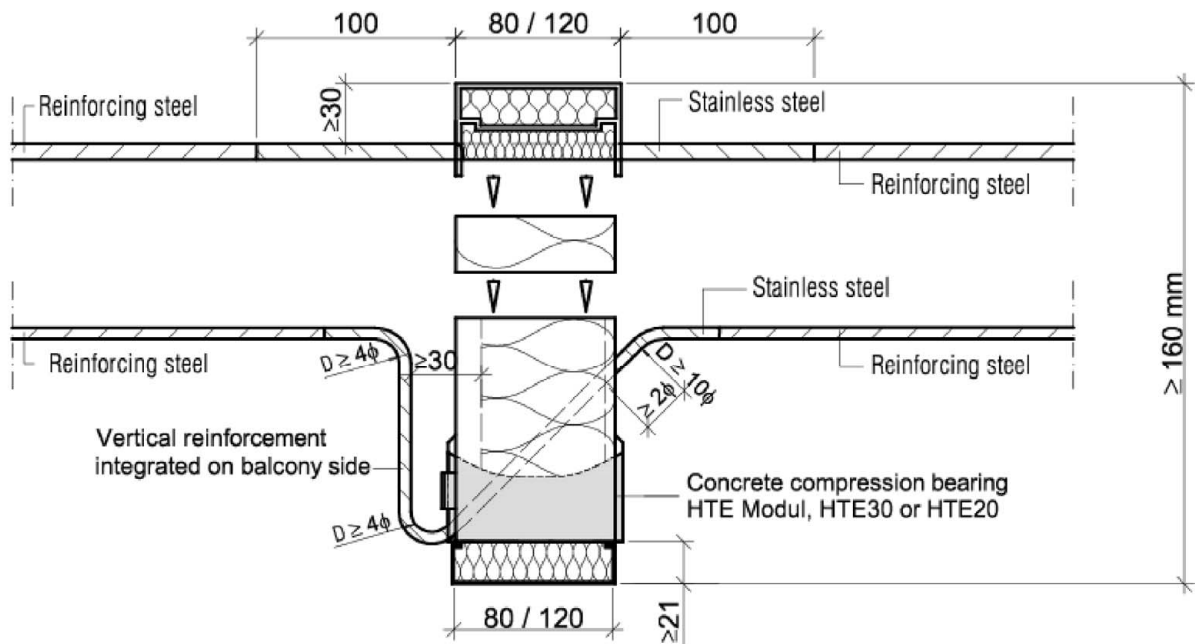

Fig. 19: Example: Schöck Isokorb® type K-F (multi-part variant) with CCE

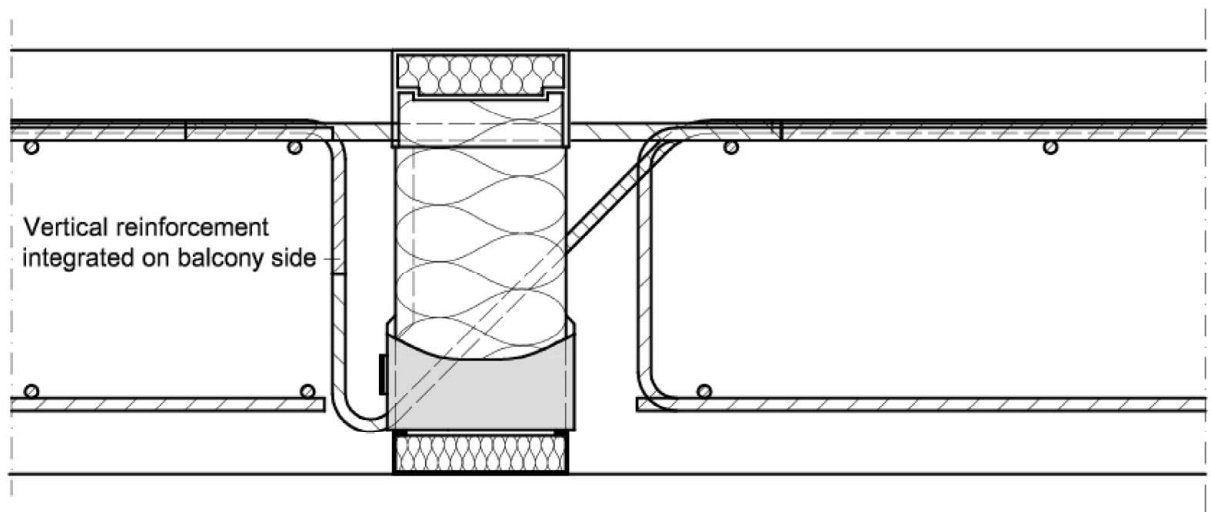

Fig. 20: Schöck Isokorb® according to Fig. 17 with CCE with indirect support

Material specification: see Section A.3

**Schöck Isokorb® with concrete compression elements**

**Intended use**

Installation Determination  
Type K and K-F with CCE - Insulation thickness 80 - 120mm

Annex B6

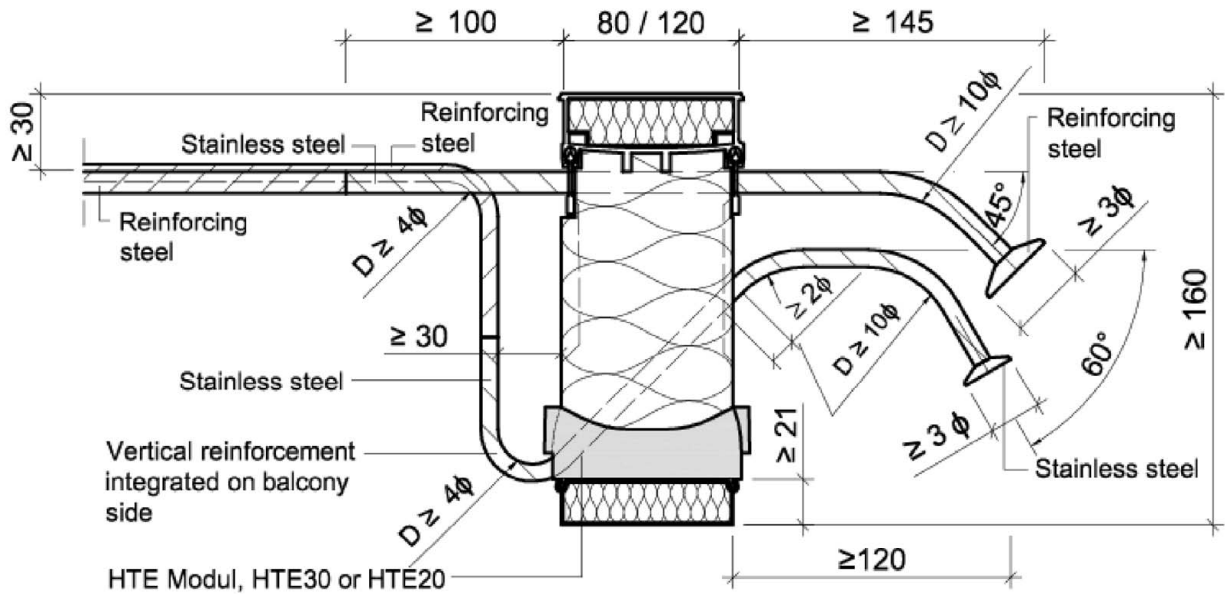

Fig. 21: Example: Schöck Isokorb® type K-O with CCE

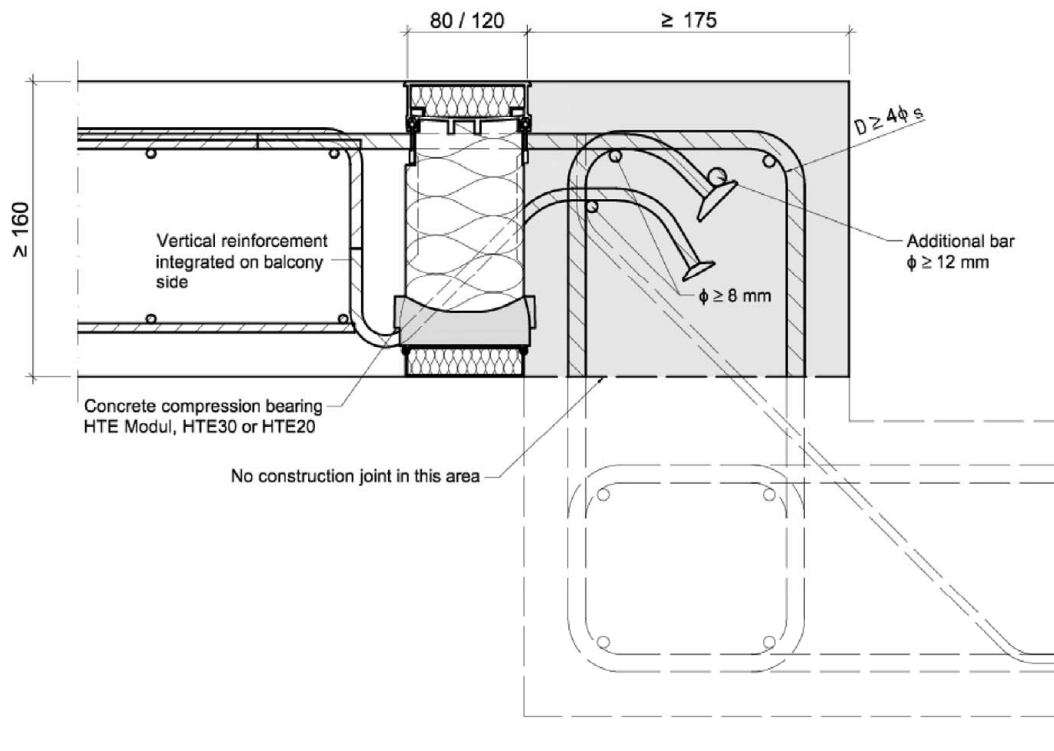

Fig. 22: Schöck Isokorb® type K-O with CCE in installed condition  
with connection to wall or height offset

**Schöck Isokorb® with concrete compression elements**

**Intended use**

Installation Determination  
Type K with CCE with indirect support and height offset variant - Insulation thickness 80 - 120mm

Annex B7

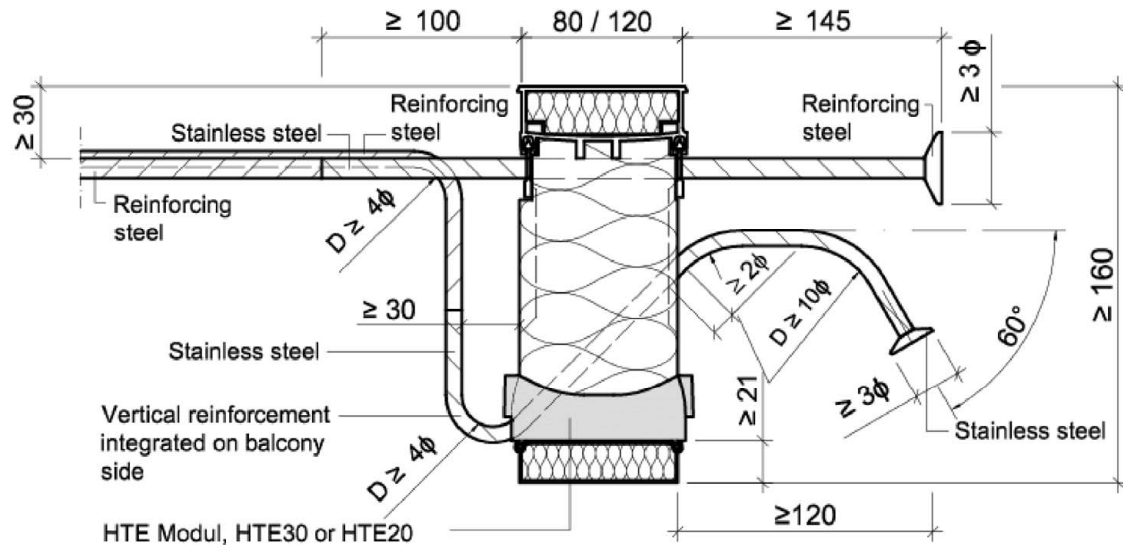

Fig. 23: Example: Schöck Isokorb® type K-U with CCE

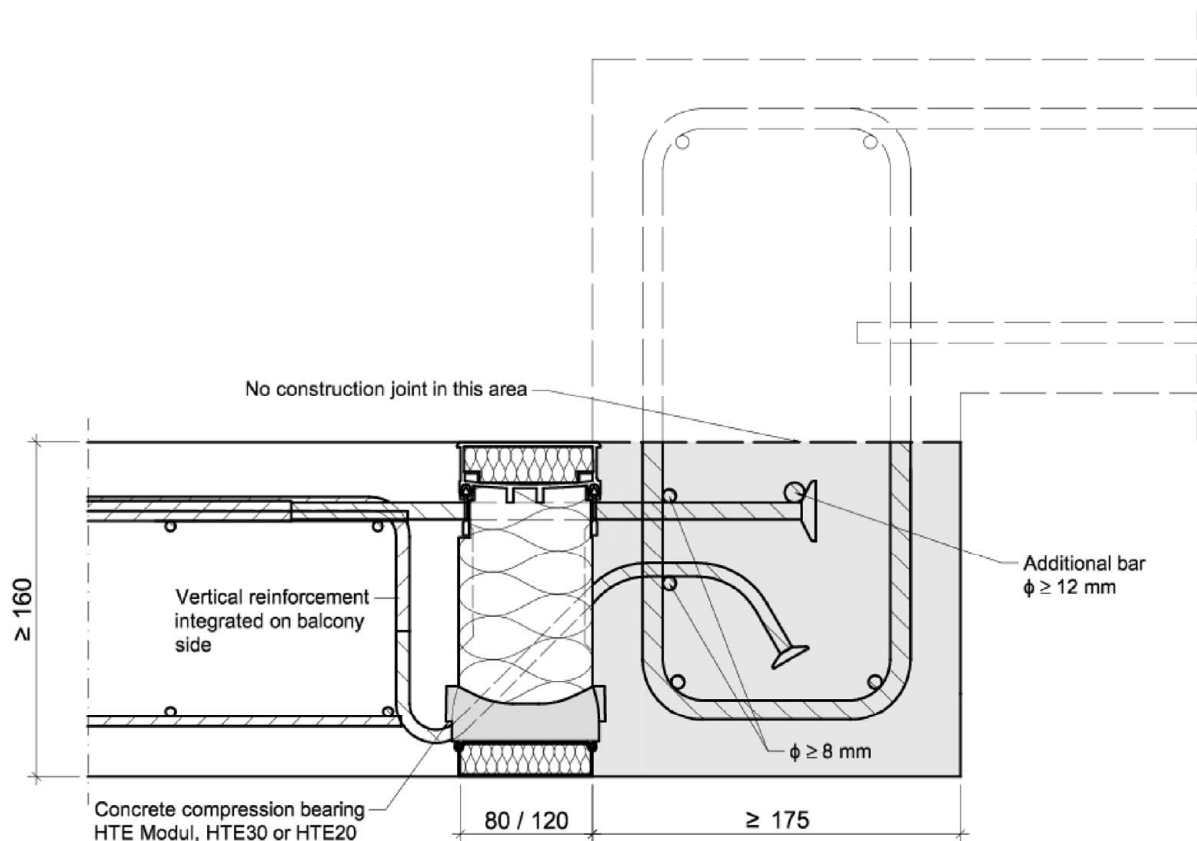

Fig. 24: Schöck Isokorb® type K-U with CCE in installed condition  
with connection to wall or height offset

**Schöck Isokorb® with concrete compression elements**

**Intended use**

Installation Determination

Type K with CCE with indirect support and height offset variant - Insulation thickness 80 - 120mm

Annex B8

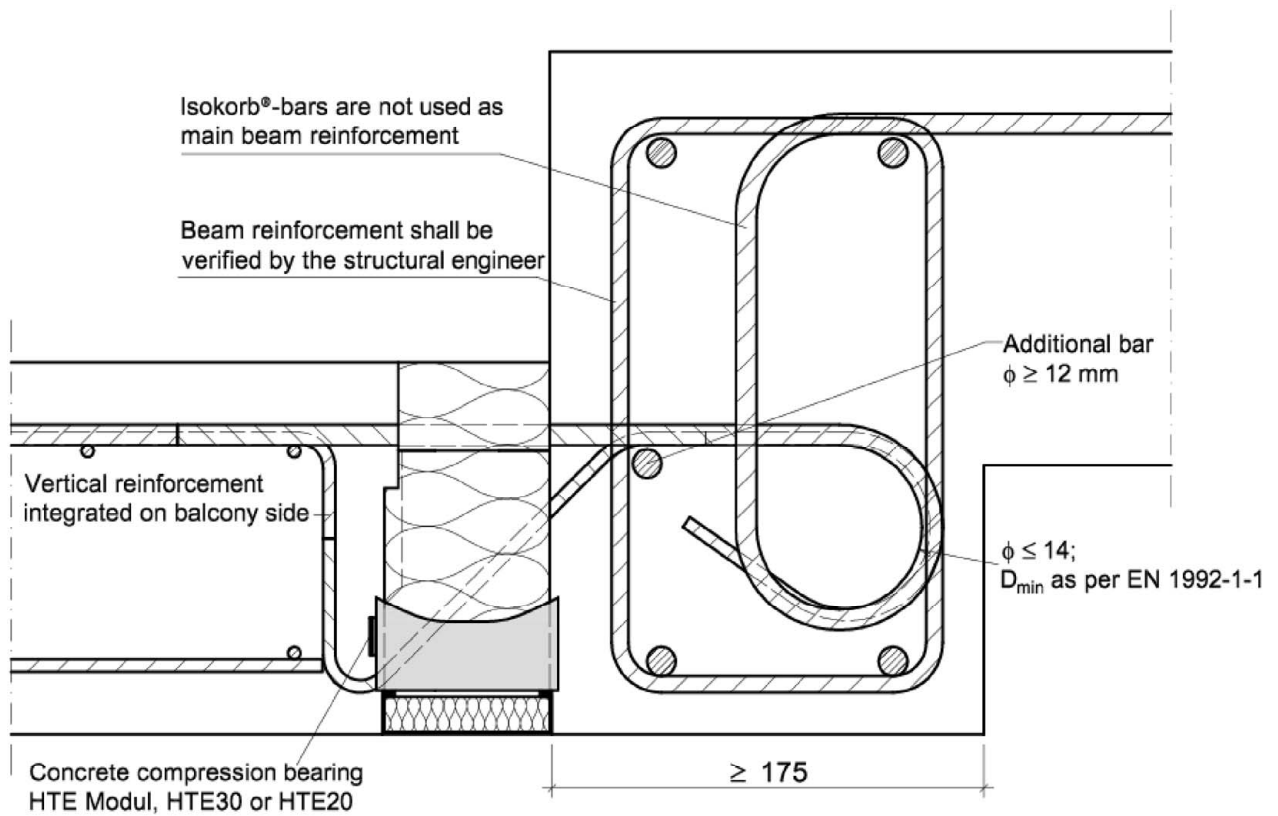

Fig. 25: Schöck Isokorb® type K-HV with CCE

**Schöck Isokorb® with concrete compression elements**

**Intended use**

Installation Determination

Type K with CCE with indirect support and height offset variant - Insulation thickness 80 - 120mm

Annex B9

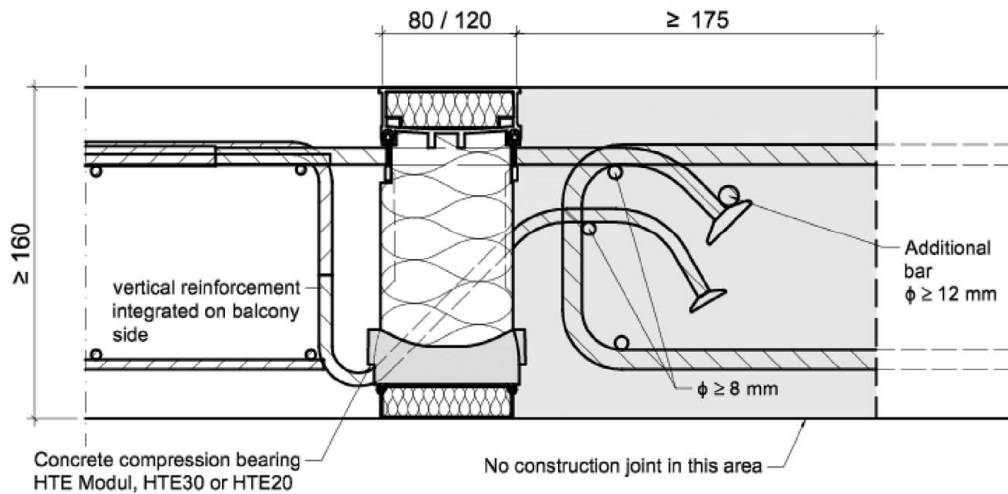

Fig. 26: Schöck Isokorb® type K-O with CCE in ceiling connection without offset

If the slabs connected to the load-bearing thermal insulation elements are implemented as prefabricated concrete slabs, the following conditions should be respected:

- In-situ concrete section (in accordance with Fig. 27: Schöck Isokorb® type K with CCE and prefabricated concrete slabs) with a width of at least 10 cm shall be carried out between the load bearing thermal insulation element and the prefabricated concrete slab
- The concrete composition of the in-situ concrete area (maximum aggregate size  $d_g$ ) shall be matched with this distance

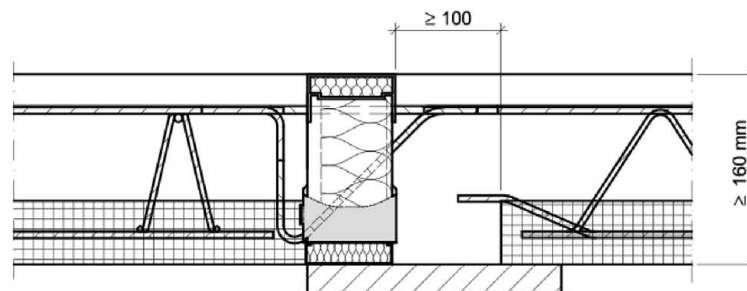

Fig. 27: Schöck Isokorb® type K with CCE and prefabricated concrete slabs

### B.2.3 Notes on use with fire protection requirements

When using the elements to connect reinforced concrete components (slabs) that are subject to fire protection requirements, the provisions of section C.2 shall be observed.

#### Schöck Isokorb® with concrete compression elements

Intended use  
Installation requirement

Annex B10

## C.1 Load-bearing capacity

### C.1.1 Load-bearing capacity of the used bars

#### C.1.1.1 Tension and shear bars

Table C.1: Design values of the yield strengths for tension loads for the bars used

| Bar made from:         | $f_{yd}$ in N/mm <sup>2</sup> |
|------------------------|-------------------------------|
| B500B NR               | 435                           |
| S355 round steel       | 323                           |
| S460 round steel       | 418                           |
| S690 round steel       | 627                           |
| B500 NR $R_{p0,2}$ 700 | 609 (for tension bars)        |
| B500 NR $R_{p0,2}$ 800 | 661 (for tension bars)        |
| B500 NR $R_{p0,2}$ 820 | 678 (for tension bars)        |

#### C.1.1.2 Tension bars with anchor heads (type K-O and type K-U)

The design value for the tensile force per bar results from the concrete strength class and anchorage of the anchor head according to Table C.2. A maximum of ten tensile bars with anchoring heads can be placed per meter.

Table C.2: Tensile capacity of tensile bars with anchor head depending on the anchorage

| Concrete strength class | Anchoring of the anchor head                              | $Z_{Rd}$ [kN] |
|-------------------------|---|---------------|
| C25/30                  | According to Fig. 47 and Fig. 48 within the hatched area  | 47,8          |
| C25/30                  | According to Fig. 47 and Fig. 48 outside the hatched area | 34,1          |
| C20/25                  | According to Fig. 47 and Fig. 48 within the hatched area  | 43,0          |
| C20/25                  | According to Fig. 47 and Fig. 48 outside the hatched area | 30,7          |

#### C.1.1.3 Shear bars with anchor heads (type K, variants -O and -U)

A maximum of six shear force bars with a nominal diameter of 8 mm with anchor head must be arranged per meter. The design values per bar are shown in Table C.3.

Table C.3: Design values per shear force bar

| Concrete strength class | $Z_{V,Rd}$ [kN] |
|-------------------------|-----------------|
| C25/30                  | 21,8            |
| C20/25                  | 19,6            |

**Schöck Isokorb® with concrete compression elements**

**Performance parameters**  
Load-bearing capacity

Annex C1

## C.1.2 Design value of the transmittable compression force $D_{Rd}$

### C.1.2.1 General

The design value of the transmittable compression force  $D_{Rd}$  is calculated depending on the compression bearing variant:

$$D_{Rd} = \min \begin{cases} n \cdot D_{Rd,c} \\ n \cdot D_{Rd,CCE} \end{cases}$$

mit:

|              |     |  |
|--------------|-----|--|
| $D_{Rd}$     | ... | Design value of the transmittable compression force in kN/m          |
| $n$          | ... | Existing number of thrust compression bearings per meter             |
| $D_{Rd,c}$   | ... | Design value for concrete edge bearing capacity in kN/ bearing pair  |
| $D_{Rd,CCE}$ | ... | Design value of the compression bearing capacity in kN/ bearing pair |

### C.1.2.2 HTE Modul

$$D_{Rd,CCE} = 34,4 \text{ kN}$$

Table C.4: Design values for the HTE Modul (alternatively HTE30)

| Minimum center distance CCE,<br>compression bearing number/m | Concrete<br>strength<br>class | $D_{Rd,c}$ in<br>kN/ bearing pair |
|--|-------------------------------|-----------------------------------|
| 5,0 cm<br>11 - 18  | C20/25                        | 25,5                              |
|  | C25/30                        | 31,8                              |
|  | $\geq$ C30/37                 | 34,4                              |
| 5,5 cm<br>11 - 16  | C20/25                        | 26,6                              |
|  | C25/30                        | 33,3                              |
|  | $\geq$ C30/37                 | 34,4                              |
| 6,0 cm<br>11 - 14  | C20/25                        | 27,8                              |
|  | C25/30                        | 34,4                              |
|  | $\geq$ C30/37                 | 34,4                              |
| 10,0 cm<br>4-10  | C20/25                        | 34,4                              |
|  | C25/30                        | 34,4                              |
|  | $\geq$ C30/37                 | 34,4                              |

For connection situations as shown in Fig. 24 and Fig. 25, the design values according to Table C.4 must be determined under consideration of  $a_{c,uz}$  and  $a_{c,h}$  and a maximum of 16 compression bearings have to be used:

with:

|            |     |               |
|------------|-----|---------------|
| $a_{c,uz}$ | ... | see Table C.5 |
| $a_{c,z}$  | ... | see Table C.6 |

If the design values exceed a compression force of 350 kN/m, four stirrups per meter shall be installed evenly on the bearing side in accordance with Annex D6 along the length of the connection.

**Schöck Isokorb® with concrete compression elements**

**Performance parameters**  
Load-bearing capacity

Annex C2



### C.1.2.3 HTE30 and HTE20

$$D_{Rd,c} = \frac{1}{1000} \cdot a_{cd} \cdot a_{c,uz} \cdot a_{c,z} \cdot c_1 \cdot \min \left( 2 \cdot c_1 + \frac{a}{44} \text{ mm} \right) \cdot (f_{ck,cube})^{1/2}$$

mit:

- $a_{cd}$  ... see Table C.7
- $c_1$  ... edge distance of the load resultant in mm according to Annex D3 and D4
- $a$  ... edge distance of the compression bearings in mm
- $f_{ck,cube}$  ... characteristic cube compressive strength in  $N/mm^2 \leq C30/37$
- $a_{c,uz}$  ... see Table C.5
- $a_{c,z}$  ... see Table C.6

Table C.5: Factor  $a_{c,uz}$  for consideration of the beam width for height offsets

| Connection situation | beam width [mm]       | $a_{c,uz}$             |
|----------------------|-----------------------|------------------------|
| Fig. 24 and Fig. 25  | $175 \leq b \leq 240$ | $0,0245 \cdot b^{2/3}$ |
|                      | $b > 240$             | 0,95                   |
| others               | -                     | 1,0                    |

Table C.6: Factor  $a_{c,z}$  for consideration of the internal lever arm

| compression force $D_{Rd}$ in kN/m | connection situation | internal lever arm $z$ [mm] | $a_{c,z}$ |
|------------------------------------|----------------------|-----------------------------|-----------|
| $\geq 350$                         | Fig. 24 and Fig. 25  | $80 \leq z \leq 150$        | 1,0       |
|                                    |                      | $z > 150$                   | $150/z$   |
|                                    | others               | -                           | 1,0       |
| $< 350$                            | general              | -                           | 1,0       |

Table C.7: Design values for HTE30 and HTE20

|   | CCE HTE20                | CCE HTE30                |                        |
|---|--------------------------|--------------------------|------------------------|
|   | without special stirrups | without special stirrups | with special stirrups* |
| $a_{cd}$  | 1,70                     | 1,80                     | 2,23                   |
| Minimum center distance CCE, compression bearing number/m | 10,0 cm<br>4 - 10        | 10,0 cm<br>4 - 10        | 8,0 cm<br>9 - 12       |
| $D_{Rd,CCE}$ [kN/bearing pair]                            | 38,0                     | 45,0                     | 45,0                   |

\* four special stirrups per meter shall be installed evenly on the bearing side in accordance with Annex D6

If the number of compression bearings is exceeded or the minimum distance between the compression bearings not reached according to Table C.7, the design values for HTE30 can be taken from Table C.4.

**Schöck Isokorb® with concrete compression elements**

**Performance parameters**  
Load-bearing capacity

Annex C3

## C.2 Fire resistance

### C.2.1 Performance features regarding load-bearing capacity In case of fire

the performance characteristics specified in Annexes C1 to C3 for verification according to the intended use under normal temperatures are met, the load bearing capacity of connections with Schöck Isokorb® is also guaranteed in case of fire for the fire resistance period indicated in Table C.9. This applies to a reduction coefficient  $\eta_{fi}$  according to EN 1992-1-2, section 2.4.2 to  $\eta_{fi} = 0,7$ , for designs according to Fig. 28 to Fig. 32 and subject to the following boundary conditions..

- The connection joint provided with the Schöck Isokorb® is completely covered with fire protection plates in accordance with Annex A5 on the top and bottom side respectively (see Appendix C5 and C6).
- The fire protection plates in the area of planned tensile loads shall be realized either with a lateral overhang on the side of 10 mm opposite the insulation body (see Annex C5, Fig. 29 and Annex C6, Fig. 32) or with additional intumescent seals on both lateral surfaces (see Annex C5, Fig. 28 and Fig. 30 and Annex C6, Fig. 31).
- The required thickness  $t$  of the fire protection plates, the minimum axis spacing  $u$  and  $v$  and the minimum concrete cover of the steel reinforcement shall be taken from Table C.8.

Table C.8: Minimum dimensions of  $c$ ,  $u$  and  $v$  and required fire protection plate thickness  $t$  in [mm]

|              |                         |
|--------------|-------------------------|
| min $c$ [mm] | 30                      |
| min $u$ [mm] | 35                      |
| min $t$ [mm] | According to data sheet |
| $v_1/v_2$ *  | 20/21                   |

\* See Annex C5

Table C.9: Fire resistance duration (load bearing capacity)

| Design variant in accordance to | Fire resistance period (load bearing capacity) in minutes |
|---------------------------------|---|
| Fig. 28                         | 120   |
| Fig. 29                         | 120   |
| Fig. 30                         | 120   |
| Fig. 31                         | 60  |
| Fig. 32                         | 60  |

**Schöck Isokorb® with concrete compression elements**

**Performance parameters**  
Load bearing capacity in case of fire

Annex C4

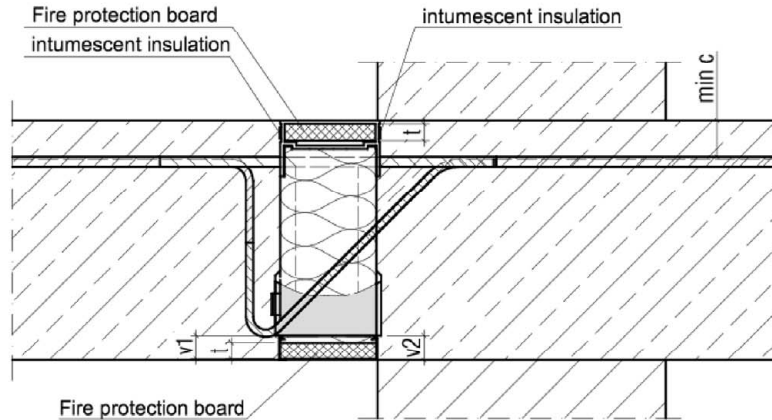

Fig. 28: Schöck Isokorb® type K and K-F with CCE

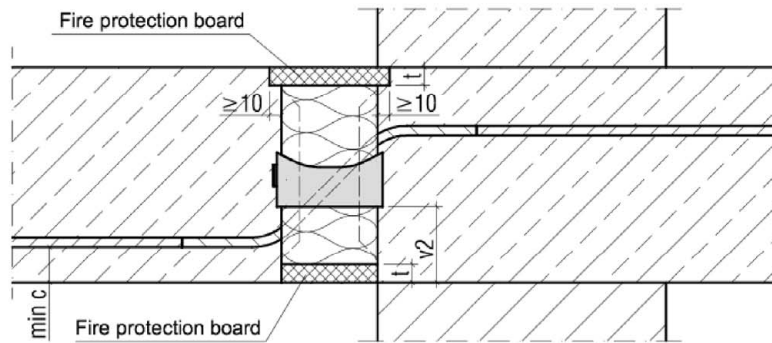

Fig. 29: Schöck Isokorb® type Q with CCE

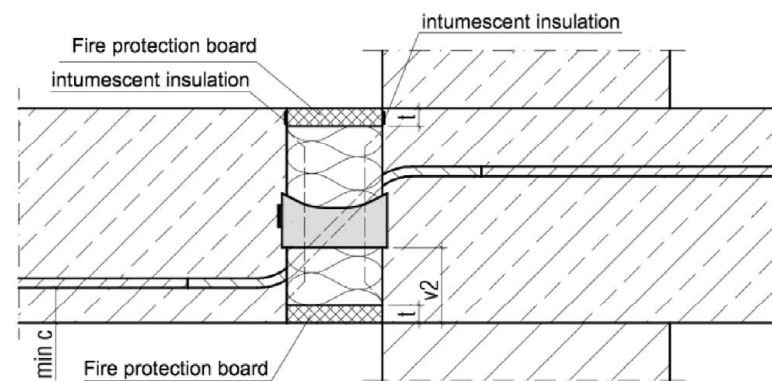

Fig. 30: Schöck Isokorb® type Q with CCE

**Schöck Isokorb® with concrete compression elements**

**Performance parameters**  
Load bearing capacity in case of fire

Annex C5

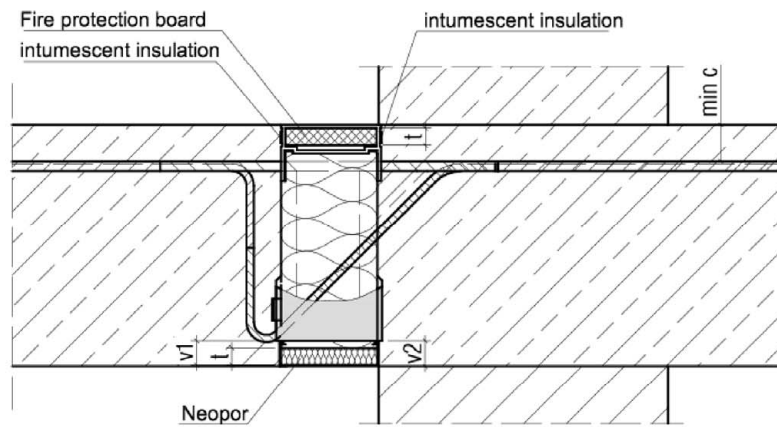

Fig. 31: Schöck Isokorb® type K and K-F with CCE

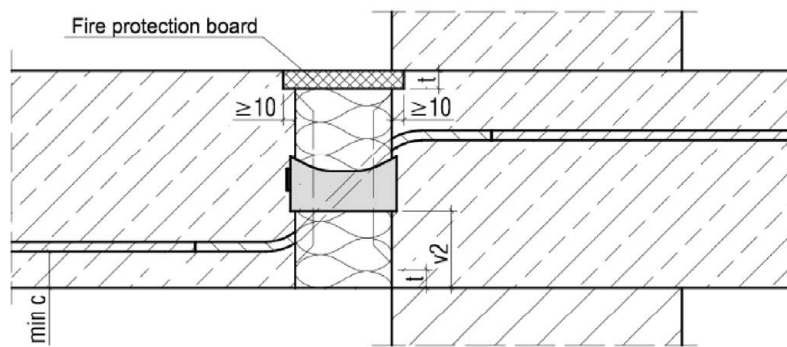

Fig. 32: Schöck Isokorb® type Q with CCE

**Schöck Isokorb® with concrete compression elements**

**Performance parameters**  
Load bearing capacity in case of fire

Annex C6

### C.2.2 Resistance to fire of building elements (informative)

Floor or roof structures as well as balcony and walkways connected to reinforced concrete components with Schöck Isokorb® as per the intended use can be classified as specified in Table C.10 in terms of fire resistance in accordance with EN 13501-2, see Annex C5 and C6. The following boundary conditions must be observed:

- The load-bearing capacity in case of fire has been declared for the Schöck Isokorb®.
- See Annex C4, bullet 1 to 3 and Table C.8.
- Connections of the remaining edges of floor or roof structures, which are not connected with the Schöck Isokorb® to adjacent or supporting components, shall be verified in accordance with the provisions of the Member States for the corresponding fire resistance.

Table C.10: Component classification

| Design variant | Floor or roof construction with fire separating function | Balcony and walkway |
|----------------|--|---------------------|
| Fig. 28        | REI 120  | R 120               |
| Fig. 29        | REI 120  | R 120               |
| Fig. 30        | REI 120  | R 120               |
| Fig. 31        | REI 60   | R 60                |
| Fig. 32        | REI 60   | R 60                |

**Schöck Isokorb® with concrete compression elements**

**Classification of building element (informative)**  
Fire resistance

Annex C7

### C.3 Thermal resistance

The equivalent thermal resistance  $R_{eq,TI}$  of Schöck Isokorb® is determined according to EN ISO 6946 and EN ISO 10211 by using finite element method and a detailed 3D model of the thermal insulation element for the configuration shown in Fig. 33:

$$R_{cal} = R_{eq,TI} + R_{con}$$

$$R_{eq,TI} = R_{cal} - R_{con} = R_{cal} - \frac{0,06 \text{ m}}{2,3 \text{ W/(m} \cdot \text{K)}}$$

$$\lambda_{eq,TI} = \frac{d_{n,TI}}{R_{eq,TI}}$$

with

$R_{cal}$  calculated thermal resistance for configuration shown in Fig. 33

$R_{eq,TI}$  equivalent thermal resistance of thermal insulation element

$R_{con}$  thermal resistance of concrete block

$d_{n,TI}$  nominal thickness of thermal insulation element

$\lambda_{eq,TI}$  equivalent thermal conductivity of thermal insulation element

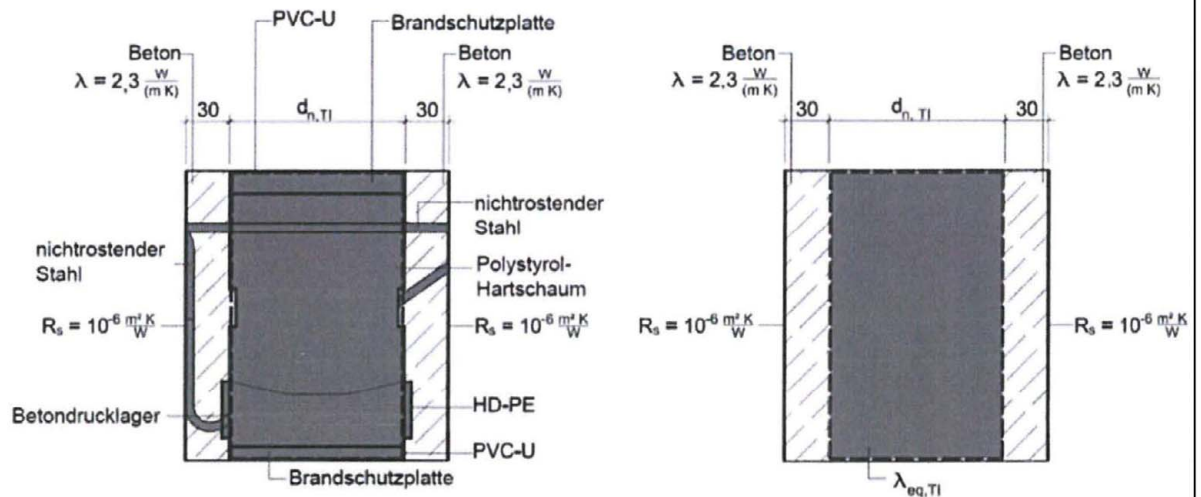

Fig. 33: cross section of configuration to calculate the equivalent thermal resistance  $R_{eq,TI}$  and simplified analogous model  $\lambda_{eq,TI}$

The design thermal conductivities of the components are given in Table C.11.

**Schöck Isokorb® with concrete compression elements**

**Performance parameters**  
Thermal resistance

Annex C8

Table C.11: Used materials and their design thermal conductivity

| Material                        | Design thermal Conductivity $\lambda$ [W/(m*K)] | Source of data  |
|---------------------------------|---|---|
| Ultra-High-Performance Concrete | According to technical documentation            | Determined according to EN 12664 and EN ISO 10456     |
| Rigid polystyrene foam (EPS)    | 0,031   | Determined according to EN ISO 13163 and EN ISO 10456 |
| Stainless steel                 | 13-15   | According to EN 10088-1                               |
| PE-HD                           | 0,5   | According to EN ISO 10456                             |
| PVC-U                           | 0,17  | According to EN ISO 10456                             |
| Fire protection plate           | According to technical documentation            | According to EN ISO 12664 and EN ISO 10456            |

**Schöck Isokorb® with concrete compression elements**

**Performance parameters**  
Thermal resistance

Annex C9

## D.1 Structural analysis

### D.1.1 General

- EN 1992-1-1 and EN 1993-1-1 shall apply to design and structural analysis (in the joint)
- Structural verification shall be performed for each individual case
- Type-tested design tables may be used

Determining of the initial forces:

- Only with linear-elastic analysis
- Analysis with redistribution, plastic analysis and non-linear analysis may not be used
- The principles for the design of frameworks in accordance with EN 1992-1-1 section 5.6.4 shall be used
- Strut-and-tie models in accordance with Annex D3 and D4 with  $z = z_{\text{strut-and-tie}}$
- Internal forces  $M_{Ed}$  and  $V_{Ed}$  shall be applied on the reference axis
- Shear reinforcements only receive tensile forces
- Variable moments and shear forces along the slab edges shall be taken into account (see section B.1.1)
- The shear force reinforcement required in the insulation layer does not determine the minimum slab thickness in accordance with EN 1992-1-1, section 9.3.2(1)

On-site vertical reinforcement on the adjacent surfaces facing the insulation of the components:

- The required vertical reinforcement results from the supporting and splitting tensile reinforcement, whereby at least a subsidiary structural edge reinforcement in accordance with section B.2.2 shall be provided

$$V = \max \left\{ \begin{array}{l} R \\ A+S \end{array} \right.$$

where:

- V ... on-site vertical reinforcement
- R ... subsidiary structural edge reinforcement in accordance with section B.2.2
- A ... supporting reinforcement
- S ... splitting reinforcement

#### - A – Supporting reinforcement

A supporting reinforcement is needed on the balcony side, if the number of the compression or tension elements is higher than the number of the shear bars. The required supporting reinforcement (and subsidiary structural edge reinforcement) covers the entire height up to the tension chord of the connected component.,

positive shear forces (directed downwards):

negative shear forces (directed upwards):

$$A = \frac{V_{Ed}}{f_{yd}} \cdot \left( 1 - \frac{n_{Q\text{-Stab}(+)}}{n_{CE}} \right) \text{ where } \frac{n_{Q\text{-Stab}(+)}}{n_{CE}} \leq 1$$

$$A = \frac{V_{Ed}}{f_{yd}} \cdot \left( 1 - \frac{n_{Q\text{-Stab}(-)}}{n_{ZS}} \right) \text{ where } \frac{n_{Q\text{-Stab}(-)}}{n_{ZS}} \leq 1$$

where:

- A ... required supporting reinforcement
- $n_{Q\text{-Stab}}$  ... number of positive (+) or negative (-) shear force bars
- $n_{CE}$  ... number of compression elements
- $n_{ZS}$  ... number of tension elements
- $V_{Ed}$  ... total acting shear force

## Schöck Isokorb® with concrete compression elements

### Structural analysis General

Annex D1



- S – splitting reinforcement

- Balcony side:

$$Z_{Sd} = 0,25 \cdot D_{Ed} \left(1 - \frac{a}{2 \cdot e^*}\right)$$

$$S_B = \frac{Z_{Sd}}{f_{yd}}$$

where:

- $Z_{Sd}$  ... resultant splitting tensile force
- $D_{Ed}$  ... orthogonal and cantered compression force acting on the subarea in accordance with Annex D3 and D4
- $a$  ... Side length of the subarea on which  $D_{Ed}$  is acting  
20 mm for HTE20  
30 mm for HTE30 and HTE Modul
- $e^*$  ... distance of the HTE to the nearest edge;  $e^* = \min(c_1; h - c_1)$
- $c_1$  ... edge distance of the load resultants in accordance with Annex D3 and D4
- $h$  ... element height
- $S_B$  ... required splitting reinforcement on the balcony side

- Floor side:

$$S_D = \begin{cases} 0 & \text{for direct support} \\ S_B & \text{for indirect support} \end{cases}$$

where:

- $S_D$  ... required splitting reinforcement on the slab side

- If the shear force is pointing up (lifting) or the compression chord is above, and the tension chord is underneath, the statements for the on-site vertical reinforcement shall be analogously adapted for the contrary load transfer
- Inclusion as a vertical reinforcement:
  - Subsidiary structural edge reinforcement in accordance with section B.2.2
  - Lattice girders with a maximum distance of 100 mm from the insulation joint
  - Special stirrups (inclusion for splitting tensile reinforcement)
  - Vertical legs of the shear force bars for Isokorb® types K, K-F, K-O, K-U and K-HV if the axial edge distance between shear reinforcement and tension reinforcement  $\leq 2\text{cm}$

**Schöck Isokorb® with concrete compression elements**

**Structural analysis**  
General

Annex D2

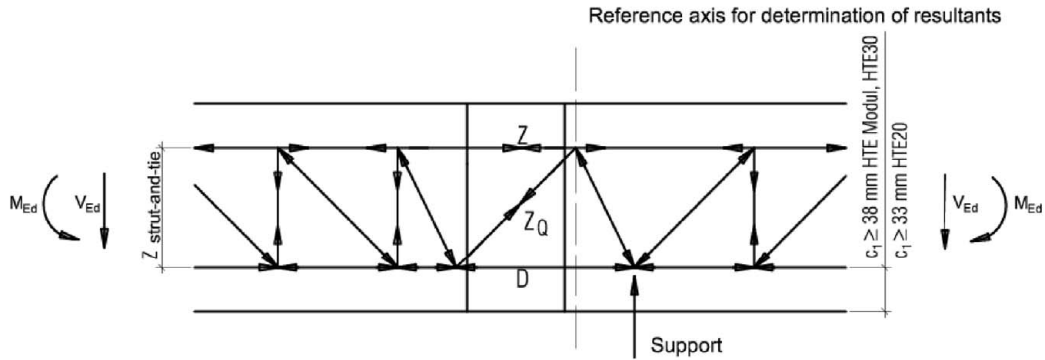

Fig. 34: Schöck Isokorb® type K and K-F (version segmented)

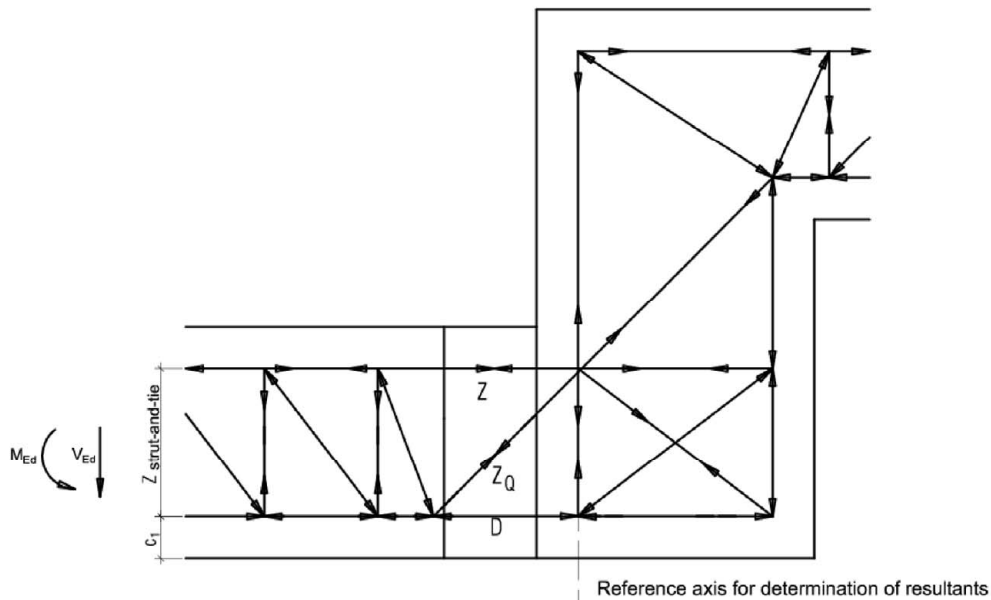

Fig. 35: Schöck Isokorb® type K (variant -HV)

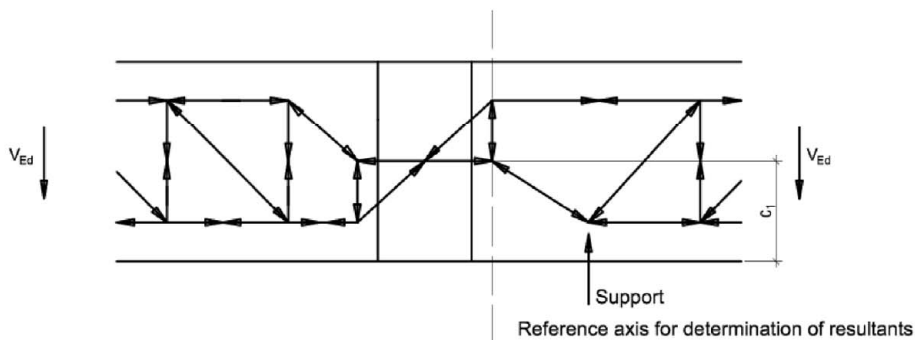

Fig. 36: Schöck Isokorb® type Q

**Schöck Isokorb® with concrete compression elements**

**Structural analysis**  
Ultimate limit states

Annex D3

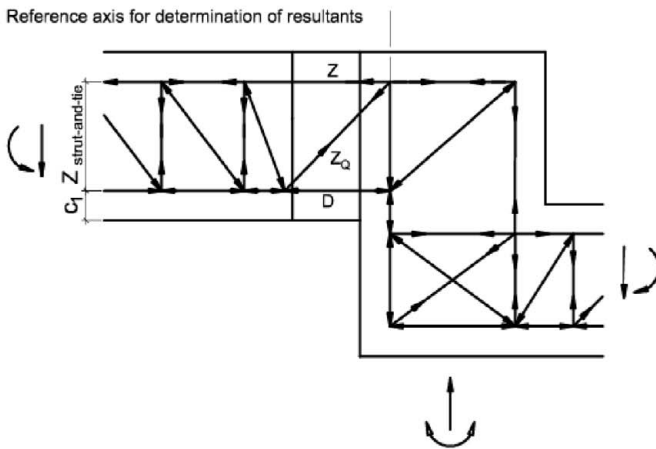

Fig. 37: Schöck Isokorb® type K-O and K-O-F with connection to height offset

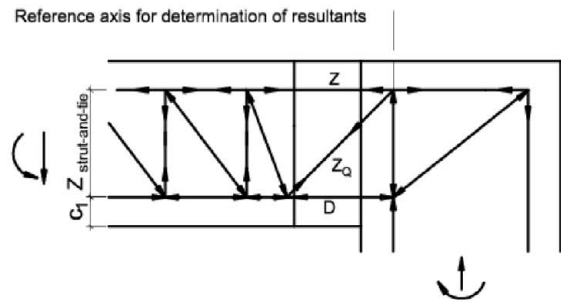

Fig. 38: Schöck Isokorb® type K-O and K-O-F with connection to wall

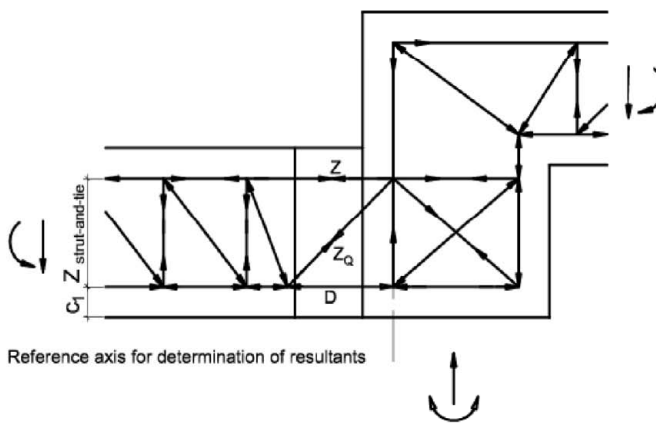

Fig. 39: Schöck Isokorb® type K-U and K-U-F with connection to height offset

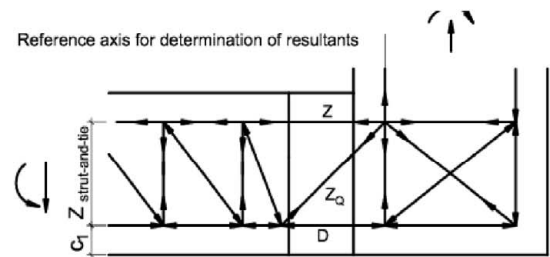

Fig. 40: Schöck Isokorb® type K-U and K-U-F with connection to wall

**Schöck Isokorb® with concrete compression elements**

**Structural analysis**  
Ultimate limit states

Annex D4

## D.1.2 Ultimate limit states

### D.1.2.1 Verification of the compression members

#### D.1.2.1.1 HTE Modul concrete compression bearing

- Design value  $D_{Rd}$  in accordance with section C.1.2.1 and in consideration of section C.1.2.2
- These design value also applies conservatively to HTE30 concrete compression bearings

#### D.1.2.1.2 HTE30 and HTE20 concrete compression bearings

- Design value of the compression bearing forces in accordance with section C.1.2.1 and in consideration of section C.1.2.3

#### D.1.2.2 Verification of the tensile bars and shear force bars

- Verification in accordance with EN 1993-1-4 and with design values in accordance with Table C.1
- Load-bearing capacity of the welded joint between reinforcing steel and stainless reinforcing steel or round steel does not need to be performed separately

#### D.1.2.3 Shear force resistance in the area of the insulation joint

- force resistance of the connecting slabs shall be carried out in consideration of EN 1992-1-1, section 6.2
- The required verification of the mandrel diameter can be omitted if the following conditions are observed:
  - o Mandrel diameter specifications given in Annexes B5, D6, D8 and D9
  - o The shear force bar axis spacing on average in the center and to the free edge or the expansion is  $\geq 10$  cm (section A.2).
- Axis spacing  $< 10$  cm: verification of the necessary mandrel diameter in accordance with EN 1992-1-1, section 8.3 shall be provided

#### D.1.2.4 Verification of the fatigue due to temperature difference

- Verification through the limitation of the joint spacing in the external structural components in accordance with Table B.1

**Schöck Isokorb® with concrete compression elements**

**Structural analysis**  
Ultimate limit states

Annex D5

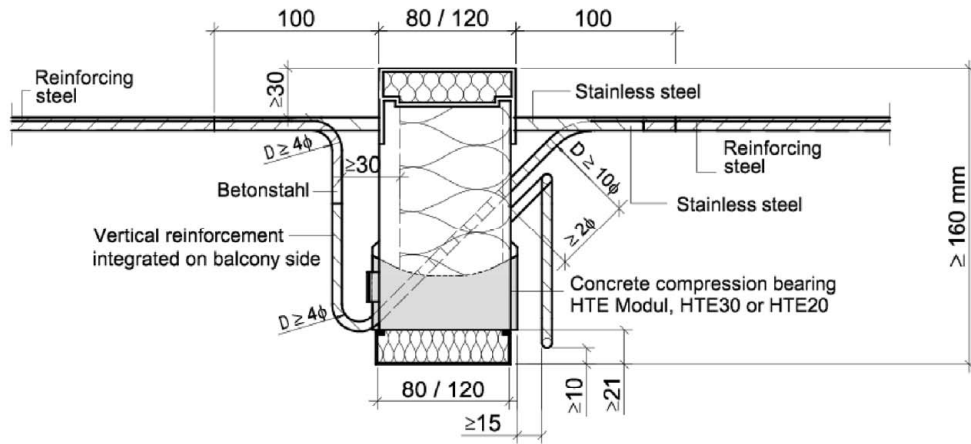

Fig. 41: Schöck Isokorb® type K <sup>1)</sup> with integrated reinforcement stirrups as per Section. D.1.1 and special stirrup

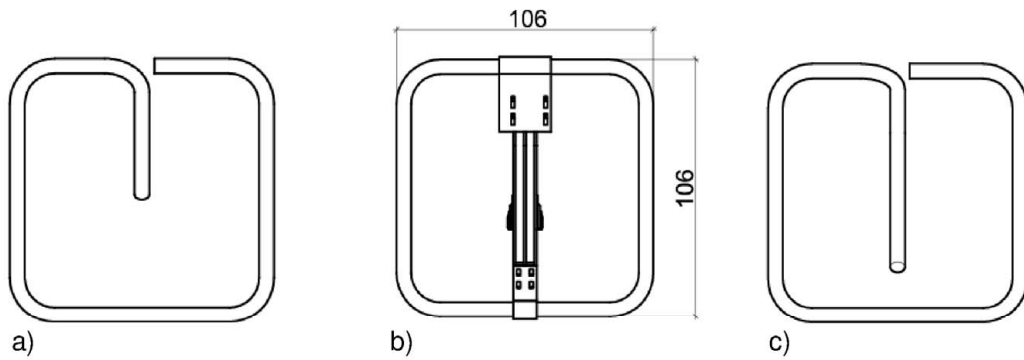

Fig. 42: Stainless steel special stirrup

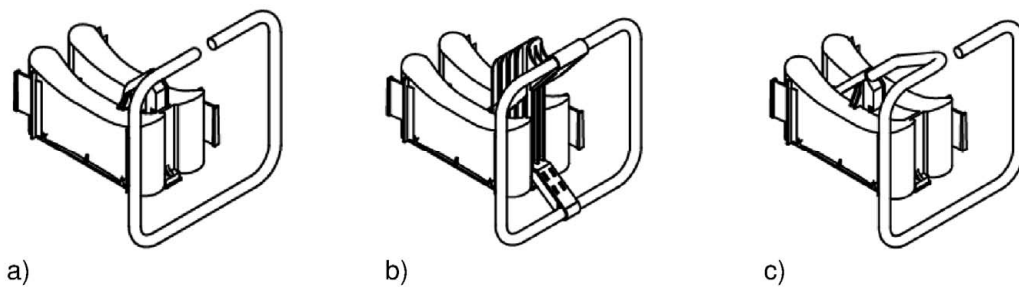

Fig. 43: Concrete compression bearing with special stirrup

<sup>1)</sup> Material specification: see Section A.3

**Schöck Isokorb® with concrete compression elements**

**Structural analysis**

Type K - Special stirrup mount variants - Insulation thickness 80 - 120 mm

Annex D6

D.1.2.5 Provisions of the verifications in the load introduction area of the concrete components

- Shear force load-bearing capacity of the undisturbed slabs in accordance with EN 1992-1-1, section 6.2
- A shear force distributed evenly across the concrete compression area shall be taken as a basis, especially for the design value of the shear force load-bearing capacity of the slabs without shear force reinforcement. Therefor the elements shall be installed with uniform spacing
- The on-site stirrup reinforcement in the anchorage area (edge beam) when using tension and shear bars with anchor head according to Annex B7 and B8 shall be designed as follows. A stirrup shall be arranged at least between two and next to the external tension or shear bars. The cross-section of the stirrups shall be designed taking into account the truss models in Annex D4 for the total acting longitudinal force of the tension and shear force bars and may be taken into account for the static checks of the edge beam.

D.1.2.6 Anchorage lengths and overlap joints of the bars leading through the thermal insulation layer

- Only ribbed steel can be taken into account for anchorage lengths and overlap joints
- The tensile bars shall be lapped to the tensile bars of the adjacent slabs
- With use of graduated tensile bars (see Annex A4) the increase in the overlap length  $\Delta l_0$  in accordance with Annex A4 Table A.1 shall be taken into account
- Anchorage of the shear force bars in the slabs in accordance with Annex D8, insofar as higher values are not yielded in accordance with EN 1992-1-1, equation (8.10)
- In cases in which shear force bars and compression members are not placed on a plane, the anchorage length for shear force bars shall also be determined in the compression zone as in the tensile zone

Shear reinforcement in accordance with EN 1992-1-1, section 8.7.4.1 shall be placed in the overlap area of the bars at an axial distance  $> 20$  mm and anchored to the section edge to resist the arising transverse tensile forces in addition to the shear reinforcement in accordance with EN1992-1-1 section 8.7.4.

Grading of the tensile reinforcement in the areas of the Schöck Isokorb® shall not be permitted.

Slab connections exclusively transfer shear forces:

- The tensile reinforcement of the slab to be connected shall be anchored in the compression zone on the frontal side with hooks
- Alternatively, stirrups on every shear force bar or lattice girders, with use of lattice girders, the tensile reinforcement must lie over the lower chords of the lattice girders (see also section B.2.2)
- The version of the shear force bar in bent form shall be possible, if the design details specified in Annex D8 are implemented

**Schöck Isokorb® with concrete compression elements**

Structural analysis  
Ultimate limit states

Annex D7

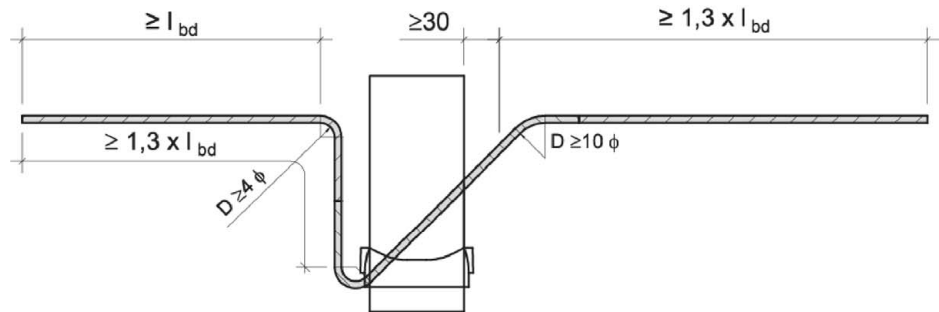

Fig. 44: Schöck Isokorb® type K / K-F (Version segmented)

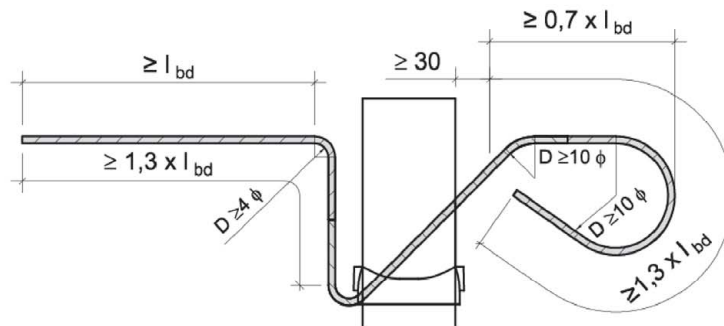

Fig. 45: Schöck Isokorb® type K / K-F (height offset variant)

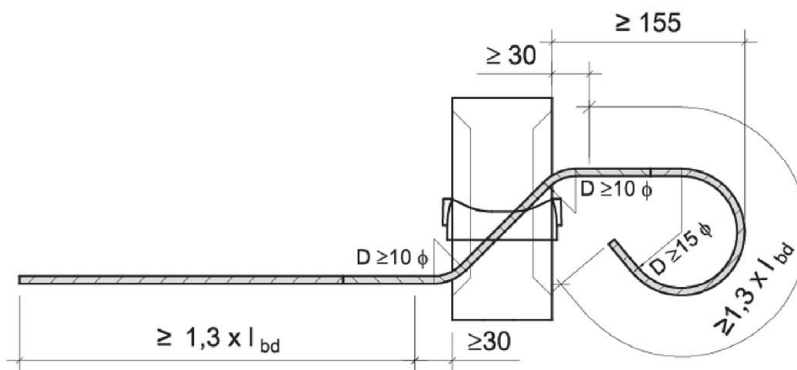

Fig. 46: Schöck Isokorb® type Q

with  $l_{bd} \geq l_{b,min}$  as per EN 1992-1-1

**Schöck Isokorb® with concrete compression elements**

**Structural analysis**

shear force bar anchoring and overlap length with CCE  
Insulation thickness 80 - 120 mm

Annex D8

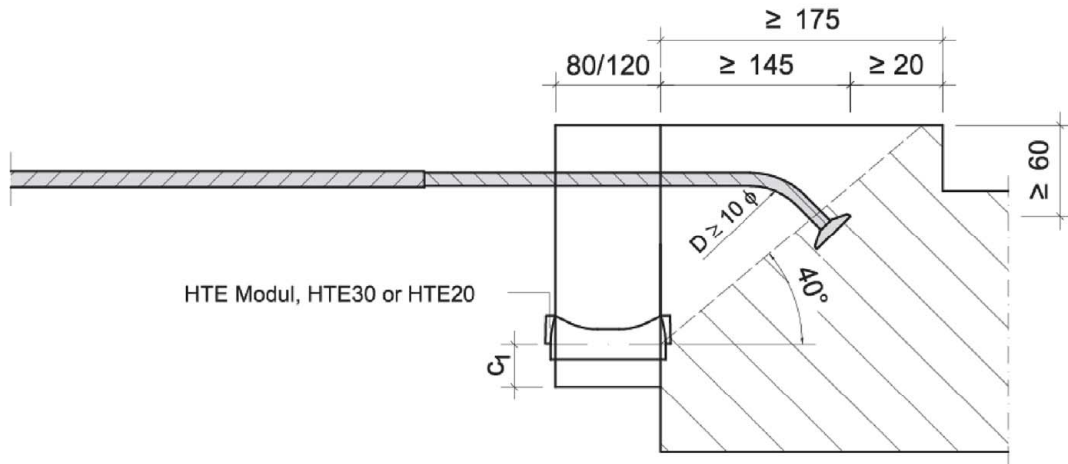

Fig. 47: Schöck Isokorb® type K-O and K-O-F

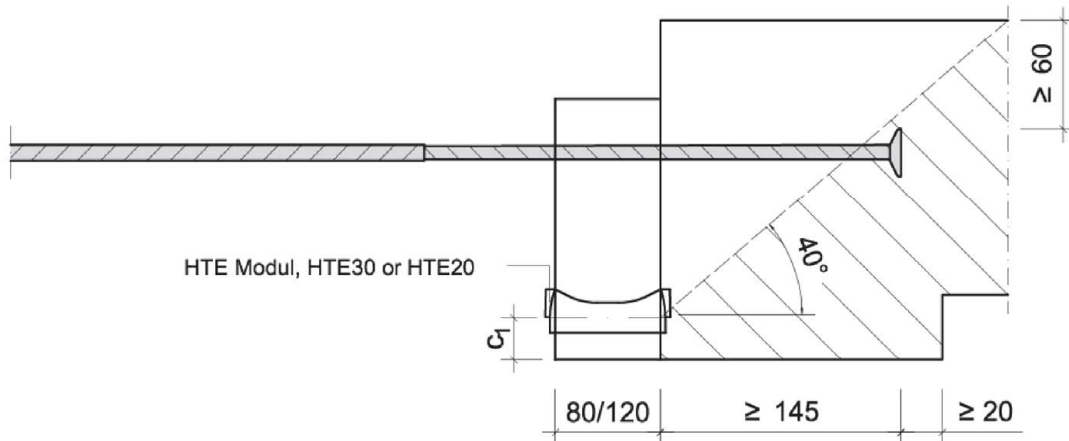

Fig. 48: Schöck Isokorb® type K-U and K-U-F

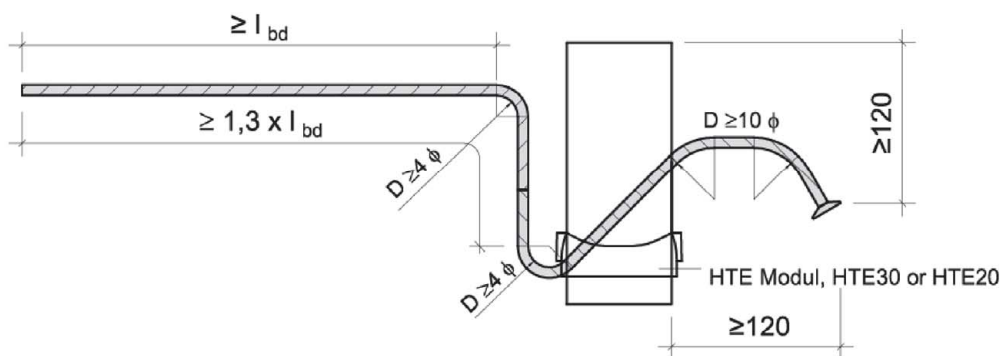

Fig. 49: Schöck Isokorb® type K-U, K-U-F, K-O and K-O-F

with  $l_{bd} \geq l_{b,min}$  as per EN 1992-1-1

**Schöck Isokorb® with concrete compression elements**

**Structural analysis**

Tension and shear force bars anchoring and overlap lengths with anchor head  
Insulation thickness 80 - 120 mm

Annex D9



Schöck Isokorb® type Q

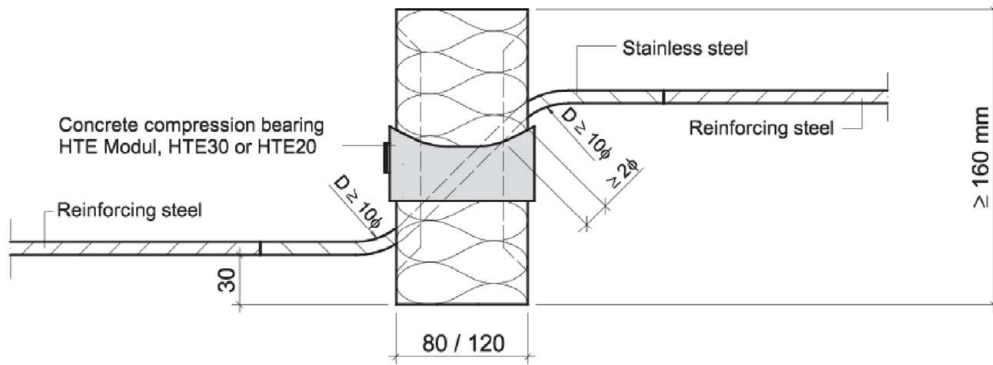

Fig. 50: Schöck Isokorb® type Q with CCE

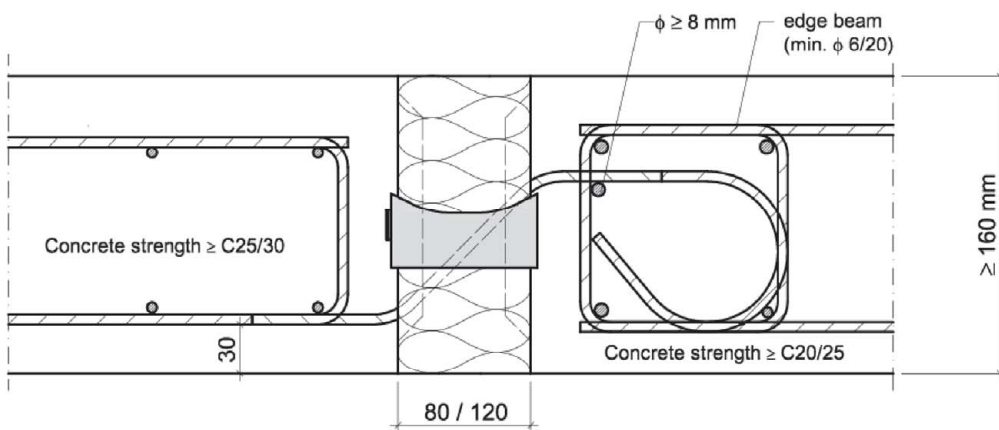

Fig. 51: Beispiel Schöck Isokorb® type Q with CCE and execution as edge beam

**Schöck Isokorb® with concrete compression elements**

**Structural analysis**

Type Q with CCE, Insulation thickness 80 - 120 mm

Annex D10

### D.1.3 Serviceability limit states

#### D.1.3.1 Control of cracking

- EN 1992-1-1 section 7.3
- No additional verification is required on the front faces of the joints or in the load introduction area if the provisions of this European technical assessment are complied with.

#### D.1.3.2 Deflection control

In the calculation of the vertical deformations, the following influential factors shall be taken into account:

- Elastic deformations of the load-bearing thermal insulation element and of the adjacent slab concrete
- Thermal expansions

Verification of the deflections:

- Quasi-continuous combination in accordance with Annexes D12 and D13
- Model for determining the bending deformation in the joint in accordance with Annexes D12 and D13
- Calculation of the elastic deformations of the tension bars depending on the yield strength that can be applied (Table C.1)

**Schöck Isokorb® with concrete compression elements**

**Structural analysis**  
Serviceability limit states

Annex D11

- Tension strap:  $\Delta l_t = \epsilon_t \cdot l_{\text{eff},t}$   
with  $E_t = 160.000 \text{ N/mm}^2$  see Fig. 53  
with  $E_t = 170.000 \text{ N/mm}^2$  see Fig. 54
- Compression bearing:  $\Delta l_d = \epsilon_d \cdot l_{\text{eff},d}$  with  $E_d = 45.000 \text{ N/mm}^2$
- Adjacent materials:  $\Delta l_{d2,GZG} = 0,275\text{mm}$
- Compression flange:  $\Delta l_d = \Delta l_{d1} + \Delta l_{d2}$
- Angle of rotation in the joint:  $\alpha_{\text{Fuge}} = (\Delta l_t + \Delta l_d)/z$

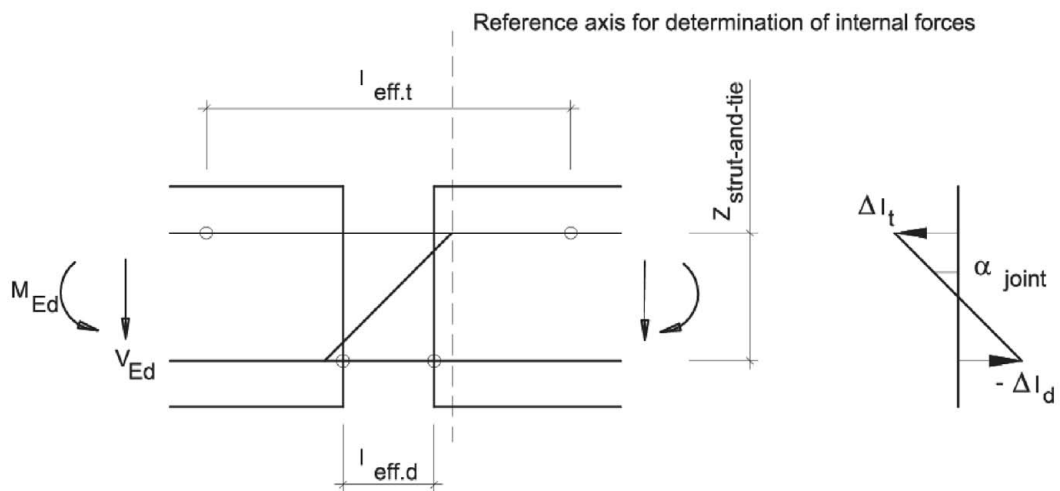

Fig. 52: Model for determining the bending deformation in the joint

Schöck Isokorb® with concrete compression elements

**Structural analysis**

Model for determining the bending deformation in the joint  
insulation thickness 80 – 120 mm

Annex D12

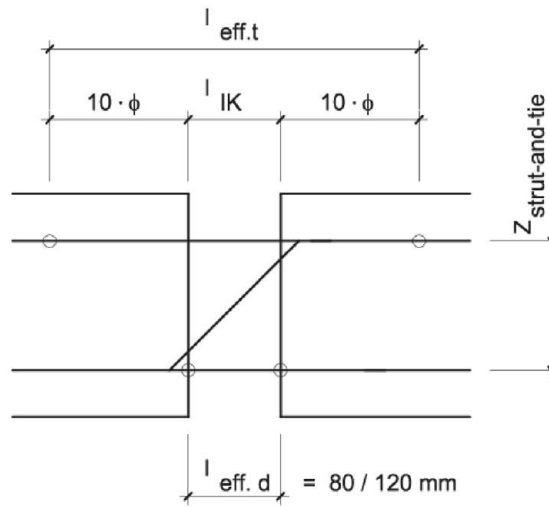

Fig. 53  $l_{\text{eff}}$  for ribbed stainless-steel bar, as per section A.3 and CCE

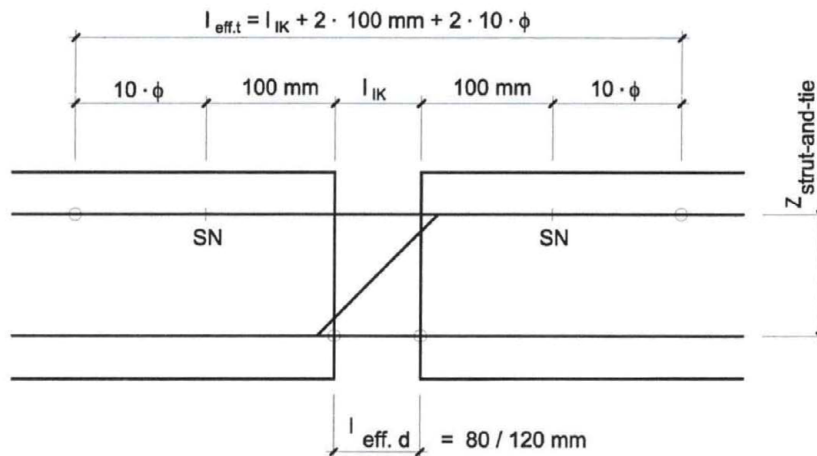

Fig. 54:  $l_{\text{eff}}$  for plain stainless-steel bar with strength classes S355, S460, S690 as per section A.3 and CCE

SN = welded joint

**Schöck Isokorb® with concrete compression elements**

**Structural analysis**

Determination of  $l_{\text{eff}}$ , - Insulation thickness 80 - 120 mm

Annex D13