

## Schöck Isokorb® T Type S



### Schöck Isokorb® T Type S

Load-bearing thermal insulation elements for the connection of freely cantilevered steel constructions to steel structures. The element consists of the S-N and S-V modules and, depending on the module arrangement, transfers moments, shear forces and normal forces.

## Assembly Section Details

S

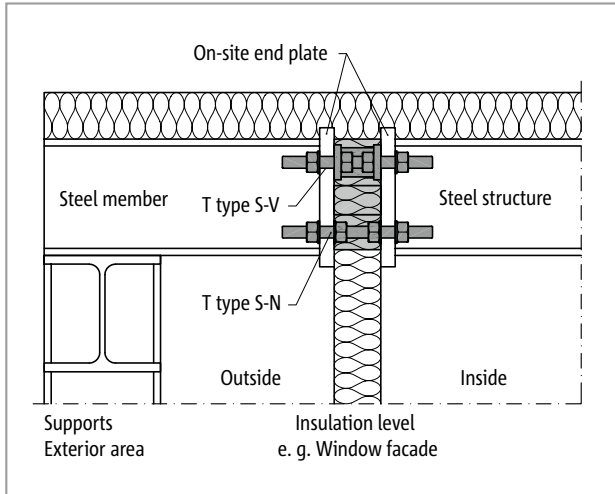

Fig. 1: Schöck Isokorb® T Type S for thermal separation within the structural system

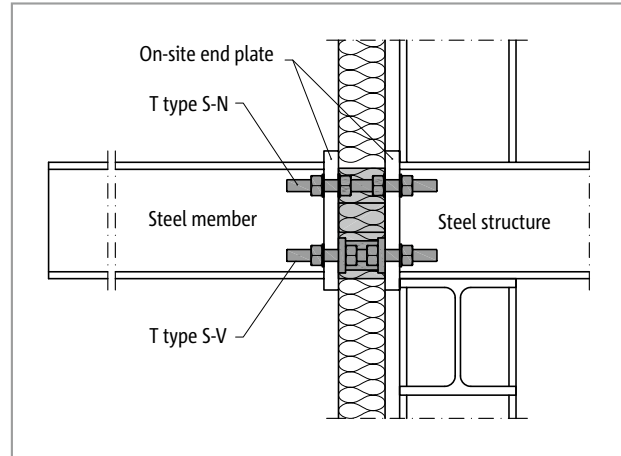

Fig. 2: Schöck Isokorb® T Type S for cantilevered steel structures

Products

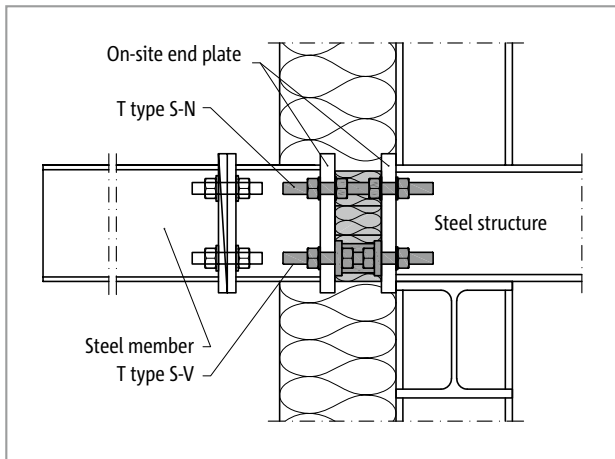

Fig. 3: Schöck Isokorb® T Type S for cantilevered steel structures ; including first fix bracket

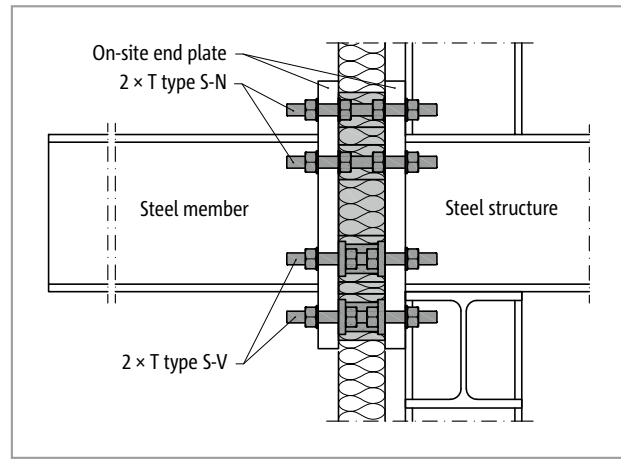

Fig. 4: Schöck Isokorb® T Type S for cantilevered steel structures

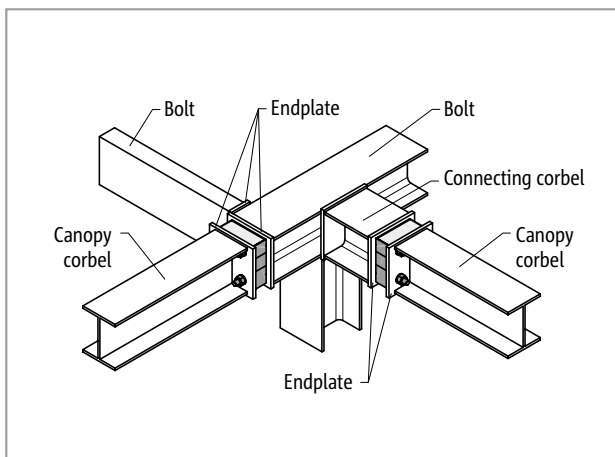

Fig. 5: Schöck Isokorb® T Type S for outer corner detail

## Assembly Section Details

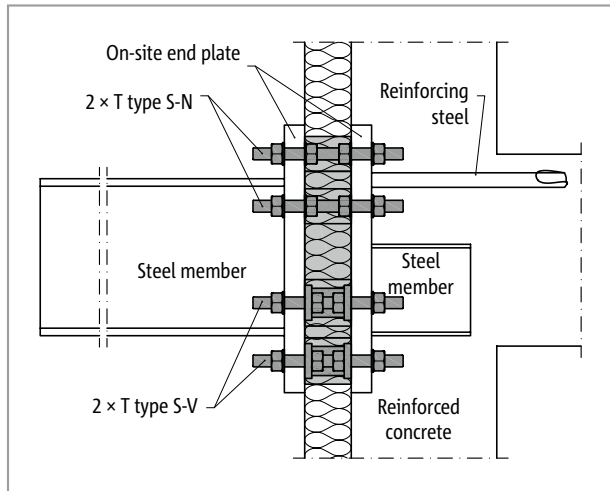

Fig. 6: Schöck Isokorb® T Type S-N and T type S-V modules for connection of steel structure to reinforced concrete frame

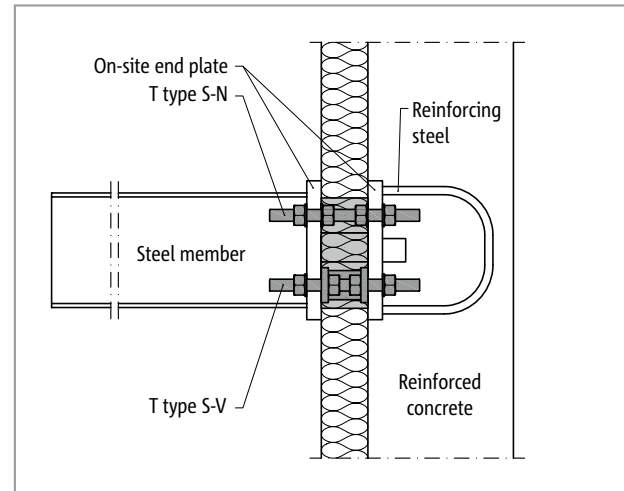

Fig. 7: Schöck Isokorb® T Type S-N and T type S-V modules for connection of steel structure to reinforced concrete frame

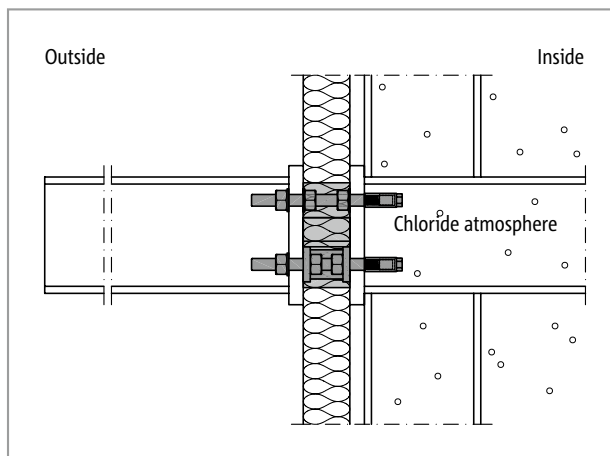

Fig. 8: Schöck Isokorb® T Type S with protective caps for cantilevered steel structure in an internal atmosphere containing chloride

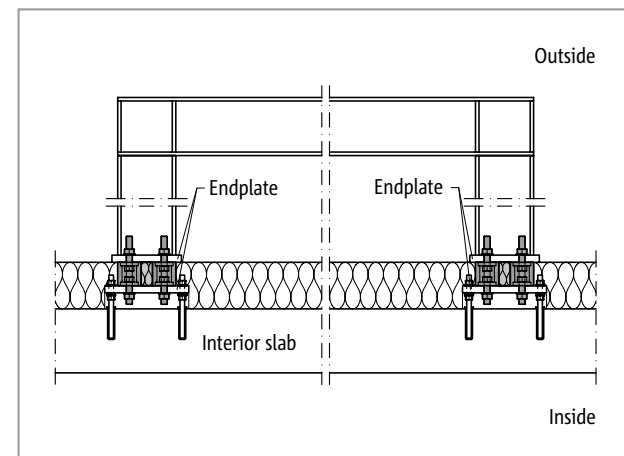

Fig. 9: Schöck Isokorb® T Type S-V for rigid frame connection for secondary structures (additional moments from imperfections are to be taken into account)

### Position of Schöck Isokorb®

For optimal thermal performance the Schöck Isokorb® should be aligned with the insulation layer.

#### **i** Notes

- When using the Schöck Isokorb® type S for roof structures, the connection must be calculated for flexural stiffness. Please contact the Schöck design department.
- Special boundary conditions must be taken into consideration when used in columns as a result of slab rotating angles and imperfections. Please contact the Schöck design department.
- The Schöck Isokorb® can only be used for relatively light vertical loads that do not influence the stability of the building.
- End plate not provided by Schöck

## Product Variants

### Schöck Isokorb® T Type S variants

The configuration of the Schöck Isokorb® T Type S can vary as follows:

- Static connection variants:
  - N: Transfers normal force
  - V: Transfers normal force and shear force: Absorbs compressive forces
- Fire resistance class:
  - R 0
- Insulating element thickness:
  - X80 = 80 mm [3 1/8"]
- Thread diameter:
  - M16, M22
- Generation:
  - 2.0
- Height:
 

T Type S-N	H = 60 mm [2.4"]
T Type S-V	H = 80 mm [3.15"]
- Height with truncated insulation elements:
 

T Type S-N	H = 40 mm [1.6"]
T Type S-V	H = 60 mm [2.4"]

(Insulation element cut off up to the steel plates; see page 8)
- Modular combination of Schöck Isokorb® T Type S-N and T Type S-V:
  - Determine according to geometric and static requirements.
  - Please take into account the number of required Schöck Isokorb® T Type S-N, T Type S-V modules in the request for proposal and with the order.

## Type Designation | Special Designs

### Type designation

The following product naming system is used to specify the attributes of the Schöck Isokorb® product as required in the structural design. This naming system ensures that the product is manufactured in accordance with the required specification. There is also a short-form of each product name to facilitate recognition of the product on the construction site during installation. Every Schöck Isokorb® product comes with both its full production designation and short-form name printed on the label on each unit to ensure the product type is clearly represented.

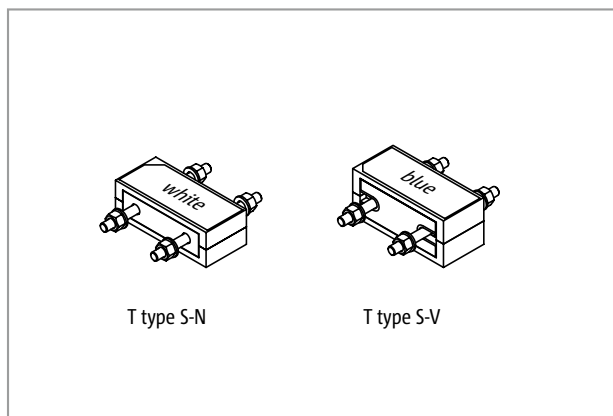
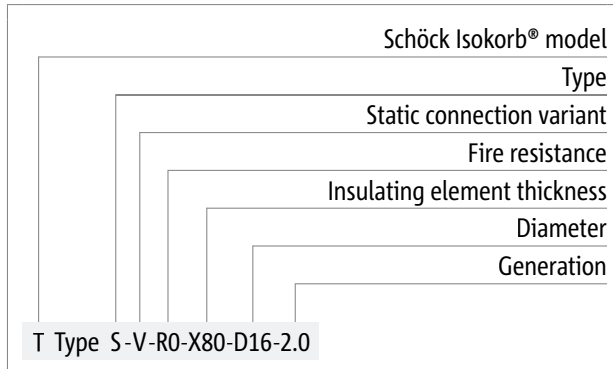

Fig. 10: Schöck Isokorb® T Type S-N and T Type S-V

### Special designs

Please contact the Technical Design Department if you have connections that are not possible with the standard product variants shown in this technical information.

## Product Description

### Schöck Isokorb® T Type S-N

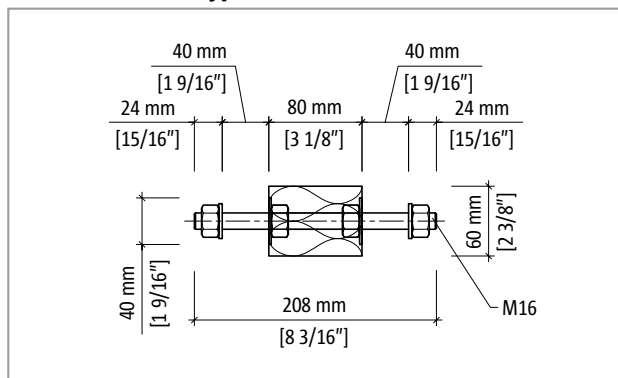

Fig. 11: Schöck Isokorb® T Type S-N-D16: Cross section of the product

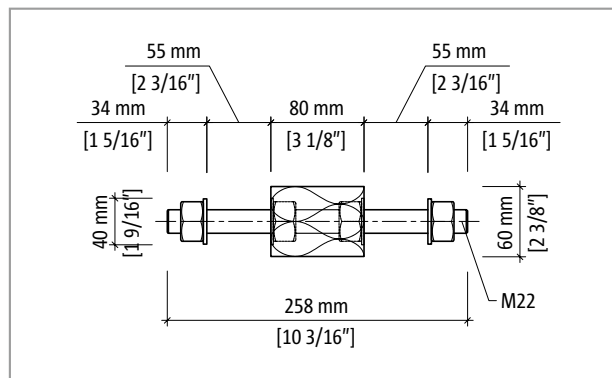

Fig. 12: Schöck Isokorb® T Type S-N-D22: Cross section of the product

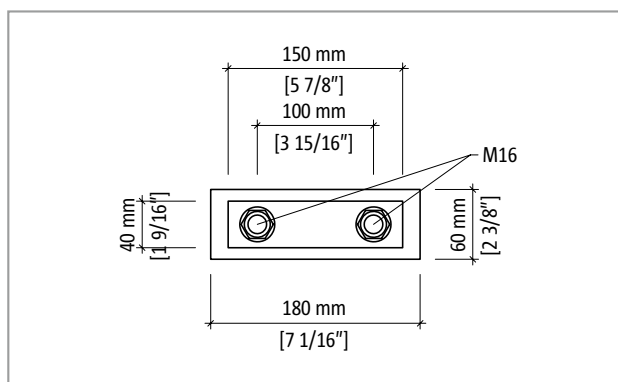

Fig. 13: Schöck Isokorb® T Type S-N-D16: Elevation of the product

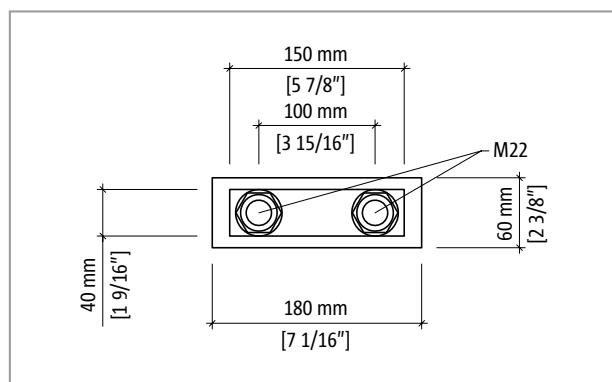

Fig. 14: Schöck Isokorb® T Type S-N-D22: Elevation of the product

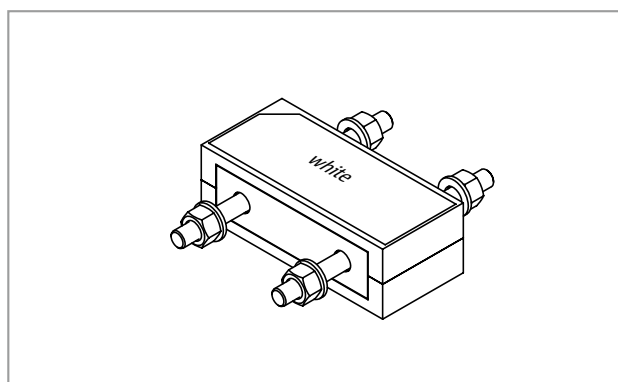

Fig. 15: Schöck Isokorb® T Type S-N-D16: Isometric view; colour code T Type S-N: White

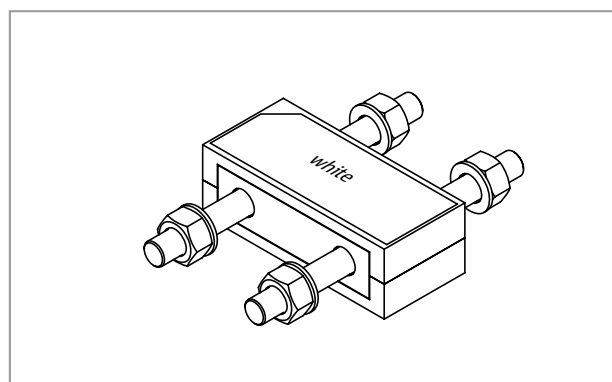

Fig. 16: Schöck Isokorb® T Type S-N-D22: Isometric view; colour code T Type S-N: White

### Product information

- The insulating element, as required, can be cut up to the steel plates.
- The free clamp length is 40 mm with threaded rods M16 and 55 mm with threaded rods M22.
- The Schöck Isokorb® and the insulation spacers can be combined according to geometric and static requirements. For this please take into account both the number of required Schöck Isokorb® and also the number of required insulation spacers

## Product Description

### Schöck Isokorb® T type S-V

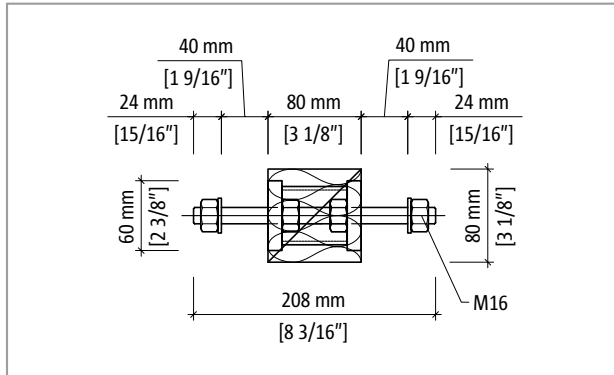

Fig. 17: Schöck Isokorb® T Type S-N-D16: Cross section of the product

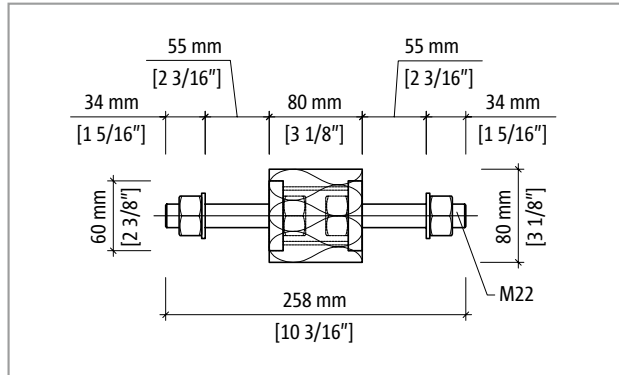

Fig. 18: Schöck Isokorb® T Type S-N-D22: Cross section of the product

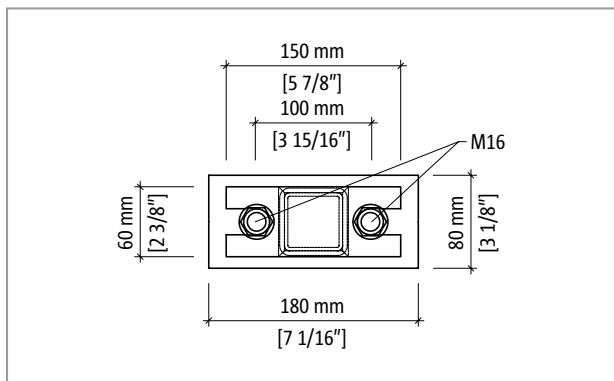

Fig. 19: Schöck Isokorb® T Type S-V-D16: Elevation of the product

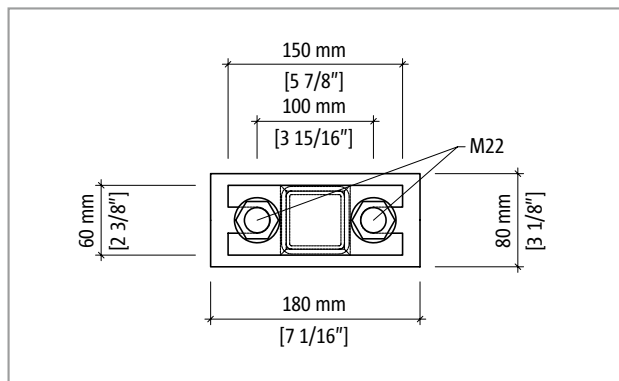

Fig. 20: Schöck Isokorb® T Type S-V-D22: Elevation of the product

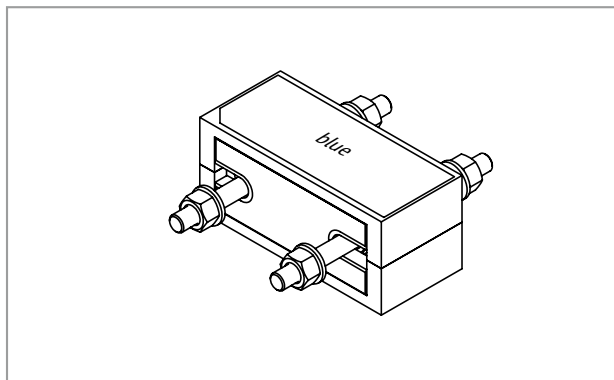

Fig. 21: Schöck Isokorb® T Type S-V-D16: Isometric view; colour code T Type S-V: Blue

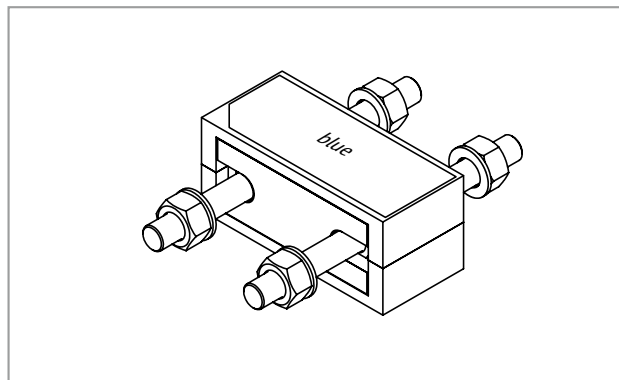

Fig. 22: Schöck Isokorb® T Type S-V-D22: Isometric view; colour code T Type S-V: Blue

### Product information

- The insulating element, as required, can be cut up to the steel plates.
- The free clamp length is 40 mm with threaded rods M16 and 55 mm with threaded rods M22.
- The Schöck Isokorb® and the insulation spacers can be combined according to geometric and static requirements. For this please take into account both the number of required Schöck Isokorb® and also the number of required insulation spacers

## Product Description | On-site fire resistance

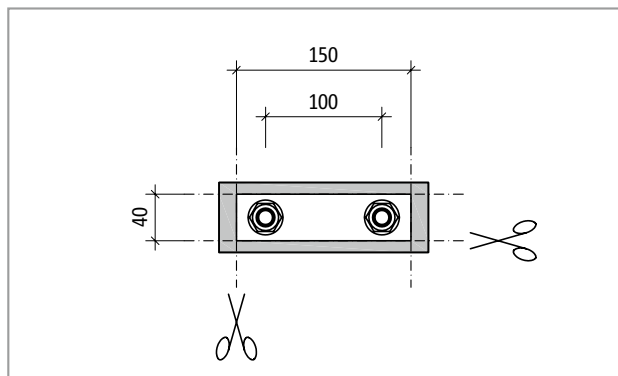

Fig. 23: Schöck Isokorb® T Type S-N: Dimensions according to cutting of insulating element

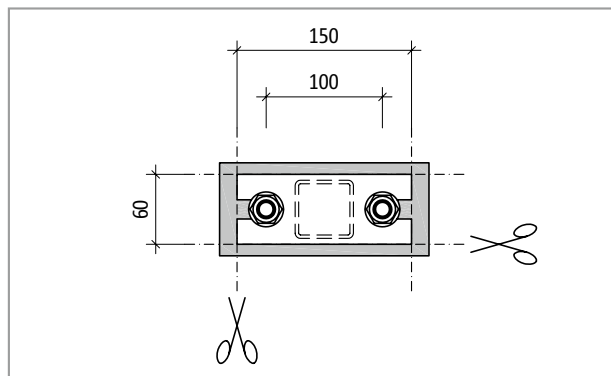

Fig. 24: Schöck Isokorb® T Type S-V: Dimensions according to cutting of insulating element

### Product information

- The insulating element, as required, can be cut up to the steel plates.
- With the combination 1 Schöck Isokorb® T Type S-N with 1 T Type S-V it applies that:  
If the insulating elements are cut around the steel plates, the lowest height is 100 mm [4"] with a vertical spacing of the threaded rods of 50 mm [2"].

### Fire protection

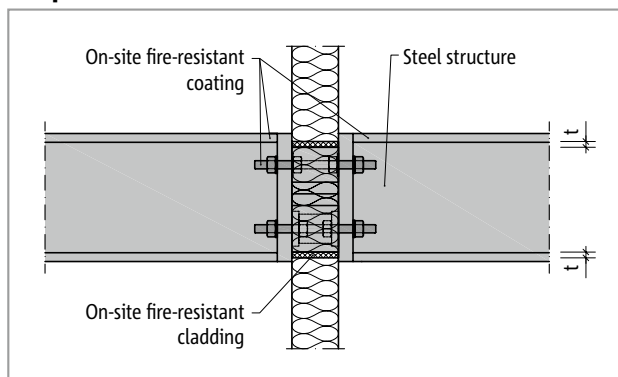

Fig. 25: Fire protection Schöck Isokorb® T Type S: On-site fire protection cladding T Type S, fire protection coated steel structure; section

### Fire protection

- The Schöck Isokorb® is available only as variant without fire protection (-R0).
- Fire-resistant cladding of the Schöck Isokorb® must be planned and installed on site. The same on-site fire safety measures apply as for the overall load-bearing structure.

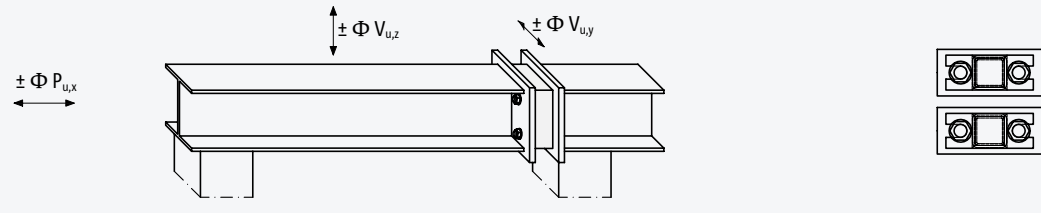
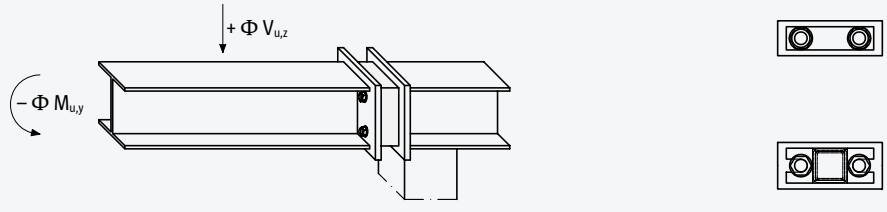
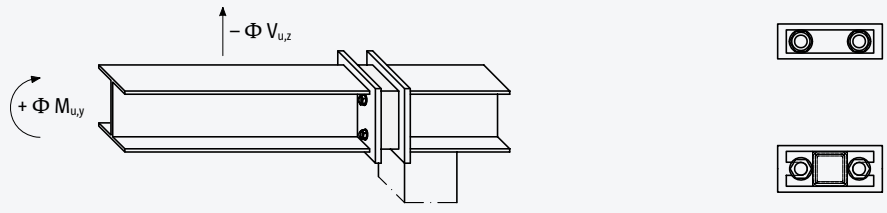
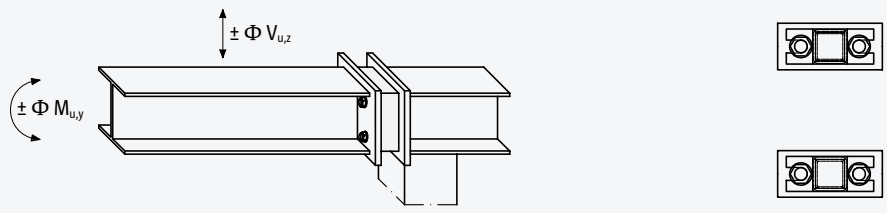

## Design overview

Normal force $\pm \Phi P_{u,x}$ , shear force $\pm \Phi V_{u,z}$ , $\pm \Phi V_{u,y}$ ; several T type S-V	Page	21
		
Shear force $+ \Phi V_{u,z}$ , moment $- \Phi M_{u,y}$ ; 1 T type S-N + 1 T type S-V	Page	16
		
Shear force $- \Phi V_{u,z}$ , moment $+ \Phi M_{u,y}$ ; 1 T type S-N + 1 T type S-V	Page	15
		
Shear force $\pm \Phi V_{u,z}$ , moment $\pm \Phi M_{u,y}$ ; 2 x T type S-V	Page	16
		

### i Design

- The design software is available for a rapid and efficient design:  
[www.schoeck.com/resources/na](http://www.schoeck.com/resources/na)
- Further information can be requested from the Technical Design Department.

## Design overview

Normal force  $\pm \Phi P_{u,x}$ , shear force  $\pm \Phi V_{u,z}$ ,  $\pm \Phi V_{u,y}$ , moment  $\pm \Phi M_{u,y}$ ,  $\pm \Phi M_{u,z}$ ; 1 T type S-N + 1 T type S-V Page 21

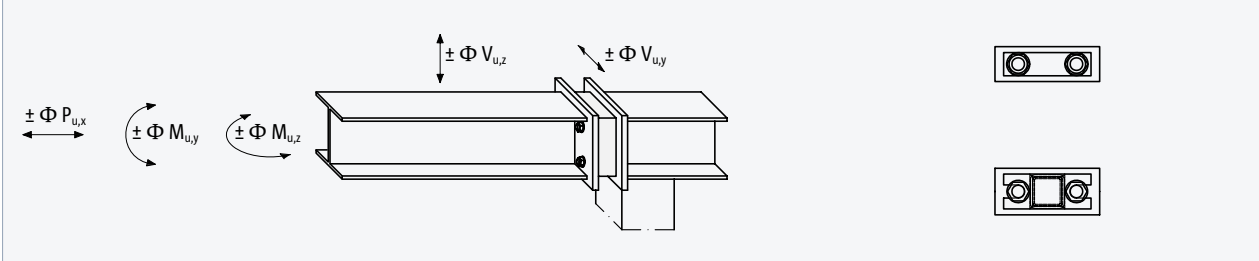

S

Normal force  $\pm \Phi P_{u,x}$ , shear force  $\pm \Phi V_{u,z}$ ,  $\pm \Phi V_{u,y}$ , moment  $\pm \Phi M_{u,y}$ ,  $\pm \Phi M_{u,z}$ ; 2 x T type S-V Page 18

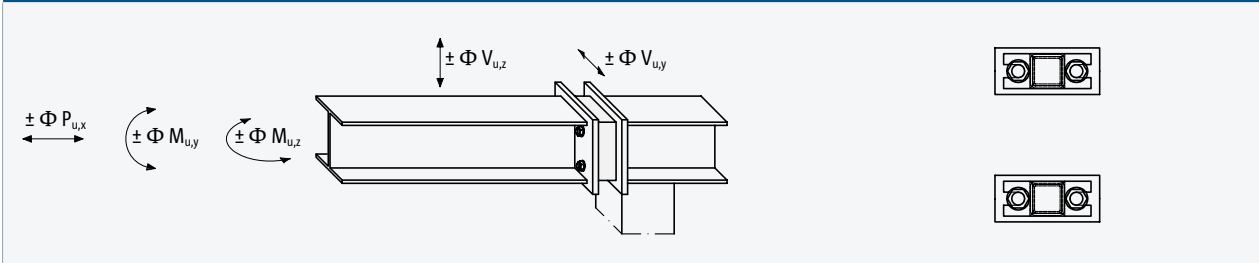

Products

### **i** Design

- The design software is available for a rapid and efficient design:  
[www.schoeck.com/resources/na](http://www.schoeck.com/resources/na)
- Further information can be requested from the Technical Design Department.

## Design overview

Normal force $\pm \Phi P_{u,x}$ , shear force $\pm \Phi V_{u,z}$ , $\pm \Phi V_{u,y}$ , moment $\pm \Phi M_{u,y}$ , $\pm \Phi M_{u,z}$ ; n × (T type S-N + T type S-V)	Page
	21

Normal force $\pm \Phi P_{u,x}$ , shear force $\pm \Phi V_{u,z}$ , $\pm \Phi V_{u,y}$ , moment $\pm \Phi M_{u,y}$ , $\pm \Phi M_{u,z}$ ; n × T type S-V	Page
	21

### i Design

- The design software is available for a rapid and efficient design:  
[www.schoeck.com/resources/na](http://www.schoeck.com/resources/na)
- Further information can be requested from the Technical Design Department.

## Sign Convention | Notes

### Sign convention for structural system

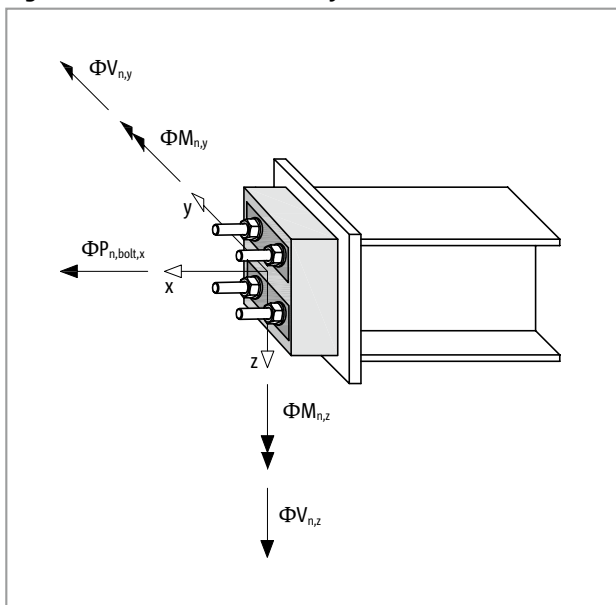

Fig. 26: Schöck Isokorb® T Type S: Sign convention for the design

### Notes on design

- The Schöck Isokorb® T Type S is intended for use with primarily static loads.
- Design takes place in accordance with approval document No. Z-14.4-518

### Design of the shear force

- It is to be decided in which zone the Schöck Isokorb® T type S-V is arranged:
  - Compression:** Both threaded rods are compression loaded.
  - Compression/tension:** One threaded rod is compression loaded, the other threaded rod is tension loaded, e. g. from  $M_{u,z}$ .
  - Tension:** Both threaded rods are tension loads.
- Interaction for all zones:
  - Allowable shear force in z-direction  $\Phi V_{n,z}$  is dependent on the shear force acting in the y-direction  $\Phi V_{n,y}$  and vice versa.
- Interaction in the compression/tension and tension zones:
  - Allowable shear force is dependent on the normal force acting  $P_{u,x}$  or the normal force from the force acting from the moment  $P_{u,x}(M_{u,z})$ .

## Design normal force and shear force

### Normal force $\phi P_{n,x}$ and shear force $\phi V_n$ - n Schöck Isokorb® T Type S-V

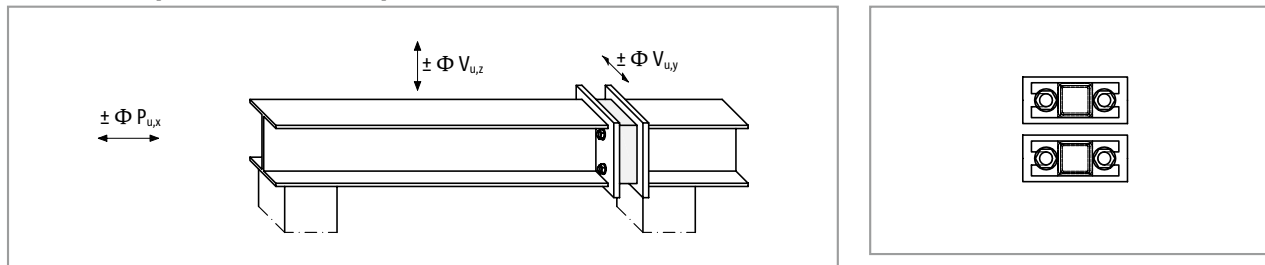

#### **i** Notes on design

- For  $P_{u,x} = 0$ , in accordance with approval, a Schöck Isokorb® T Type S-V module is allocated in the tension zone. Further Schöck Isokorb® T type S-V may be assigned to the compression zone.
- The design values given in this table apply for a pure supported connection. It is to be ensured that a flexible connection is also available with the arrangement of several Schöck Isokorb® T Type S-V modules.
- The design values apply only for supported steel constructions and with a two-sided rigid connection of the on-site end plates.
- The 4 Teflon sheets installed for each type S-V in use add approximately 4 mm [5/32"]. In particular with low balcony loading and with small centre-to-center distance between type S-N and type S-V, these additional 4 mm [5/32"] in the compression zone have an impact relevant to the camber of the steel beams connected with Schöck Isokorb®. Should shims be necessary for on-site levelling in the tension zone, this would be taken into account with the construction planning.

## Design normal force and shear force

Schöck Isokorb® T type	n × S-V-D16		n × S-V-D22			
Design value per	$\phi P_{n,x}$ [kN/module]					
Module	±116.8		±225.4			
Shear force compression zone						
Module	$\phi V_{n,z}$ [kN/module]					
	±(46 - $ \phi V_{u,y} $ )		±(50 - $ \phi V_{u,y} $ )			
	$\phi V_{n,y}$ [kN/module]					
	±min {23; 46 - $ \phi V_{u,z} $ }		±min {25; 50 - $ \phi V_{u,z} $ }			
Shear force tension zone						
Module	$\phi V_{n,y}$ [kN/module]					
	for	$0 < \phi N_{u,x} \leq 26.8$	±(30 - $ \phi V_{u,y} $ )	for	$0 < \phi N_{u,x} \leq 117.4$	±(36 - $ \phi V_{u,y} $ )
	for	$26.8 < \phi N_{u,x} \leq 116.8$	±(1/3 (116.8 - $\phi N_{u,x}$ ) - $ \phi V_{u,y} $ )	for	$117.4 < \phi N_{u,x} \leq 225.4$	±(1/3 (225.4 - $\phi N_{u,x}$ ) - $ \phi V_{u,y} $ )
	$\phi V_{n,y}$ [kN/module]					
	for	$0 < \phi N_{u,x} \leq 26.8$	±min {23; 30 - $ \phi V_{u,z} $ }	for	$0 < \phi N_{u,x} \leq 117.4$	±min {25; 36 - $ \phi V_{u,z} $ }
for	$26.8 < \phi N_{u,x} \leq 116.8$	±min {23; 1/3 (116.8 - $\phi N_{u,x}$ ) - $ \phi V_{u,z} $ }	for	$117.4 < \phi N_{u,x} \leq 225.4$	±min {25; 1/3 (225.4 - $\phi N_{u,x}$ ) - $ \phi V_{u,z} $ }	

Schöck Isokorb® T type	n × S-V-D16		n × S-V-D22			
Design value per	$\phi P_{n,x}$ [kip/module]					
Module	±26.3		±50.7			
Shear force compression zone						
Module	$\phi V_{n,z}$ [kip/Module]					
	±(10.3 - $ \phi V_{u,y} $ )		±(11.2 - $ \phi V_{u,y} $ )			
	$\phi V_{n,y}$ [kip/module]					
	±min {5.2; 10.3 - $ \phi V_{u,z} $ }		±min {5.6; 11.2 - $ \phi V_{u,z} $ }			
Shear force tension zone						
Module	$\phi V_{n,y}$ [kip/module]					
	for	$0 < \phi N_{u,x} \leq 6$	±(6.7 - $ \phi V_{u,y} $ )	for	$0 < \phi N_{u,x} \leq 26.4$	±(8.1 - $ \phi V_{u,y} $ )
	for	$6 < \phi N_{u,x} \leq 26.3$	±(1/3 (26.3 - $\phi N_{u,x}$ ) - $ \phi V_{u,y} $ )	for	$26.4 < \phi N_{u,x} \leq 50.7$	±(1/3 (50.7 - $\phi N_{u,x}$ ) - $ \phi V_{u,y} $ )
	$\phi V_{n,y}$ [kip/module]					
	for	$0 < \phi N_{u,x} \leq 6$	±min {5.2; 6.7 - $ \phi V_{u,z} $ }	for	$0 < \phi N_{u,x} \leq 26.4$	±min {5.6; 8.1 - $ \phi V_{u,z} $ }
for	$6 < \phi N_{u,x} \leq 26.3$	±min {5.2; 1/3 (26.3 - $\phi N_{u,x}$ ) - $ \phi V_{u,z} $ }	for	$26.4 < \phi N_{u,x} \leq 50.7$	±min {5.6; 1/3 (50.7 - $\phi N_{u,x}$ ) - $ \phi V_{u,z} $ }	

## Design shear force and moment

### Positive shear force $\phi V_{n,z}$ and negative moment $\phi M_{n,y}$ - 1 Schöck Isokorb® T Type S-N and 1 Schöck Isokorb® T Type S-V

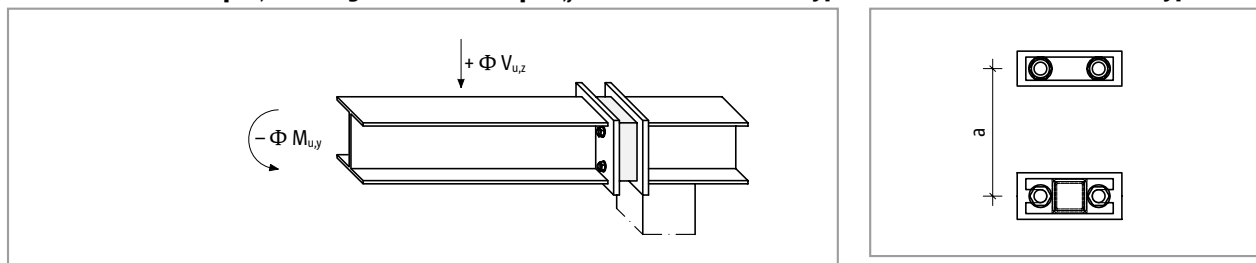

Schöck Isokorb® T type S-N, S-V 2.0	1 × S-N-D16 + 1 × S-V-D16	1 × S-N-D22 + 1 × S-V-D22
Design value per	$\phi M_{n,y}$ [kNm/connection]	
Connection	$-116.8 \cdot a$	$-225.4 \cdot a$
	$\phi V_{n,z}$ [kN/connection]	
Connection	46	50

Schöck Isokorb® T type S-N, S-V 2.0	1 × S-N-D16 + 1 × S-V-D16	1 × S-N-D22 + 1 × S-V-D22
Design value per	$\phi M_{n,y}$ [kip.ft/connection]	
Connection	$-26.3 \cdot a$	$-50.7 \cdot a$
	$\phi V_{n,z}$ [kip/connection]	
Connection	10.3	11.2

#### **i** Notes on design

- Minimum lever arm  $a = 50$  mm [2"] (without insulation spacers and after cutting insulation element to size see page 8)
- The load case presented here (positive shear force and negative moment) can be combined with the load case presented next (negative shear force and positive moment) for the same connection.

## Design shear force and moment

### Negative shear force $\phi V_{n,z}$ and positive moment $\phi M_{n,y}$ - 1 Schöck Isokorb® T Type S-N and 1 Schöck Isokorb® T Type S-V

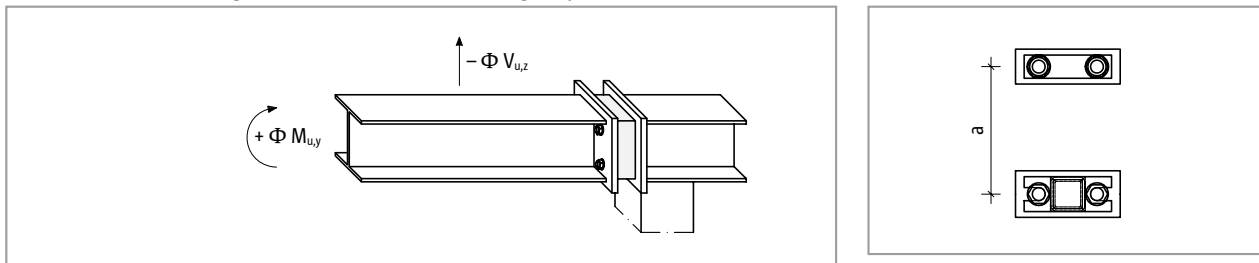

Schöck Isokorb® T type	1 × S-N-D16 + 1 × S-V-D16			1 × S-N-D22 + 1 × S-V-D22		
Design value per	$\phi M_{n,y}$ [kNm/connection]					
Connection	63.4 · a			149.6 · a		
	$\phi V_{n,z}$ [kN/connection]					
Connection	for	$0 < \phi N_{u,x} (\phi M_{u,y}) \leq 26.8$	-30	for	$0 < \phi N_{u,x} (\phi M_{u,y}) \leq 117.4$	-36
	for	$26.8 < \phi N_{u,x} (\phi M_{u,y}) < 63.4$	$-1/3 (116.8 - \phi N_{u,x} (\phi M_{u,y}))$	for	$117.4 < \phi N_{u,x} (\phi M_{u,y}) < 149.6$	$-1/3 (225.4 - \phi N_{u,x} (\phi M_{u,y}))$
	for	63.4	-17.8	for	149.6	-25.3

Schöck Isokorb® T type	1 × S-N-D16 + 1 × S-V-D16			1 × S-N-D22 + 1 × S-V-D22		
Design value per	$\phi M_{n,y}$ [kip.ft/connection]					
Connection	14.2 · a			33.6 · a		
	$\phi V_{n,z}$ [kip/connection]					
Connection	for	$0 < \phi N_{u,x} (\phi M_{u,y}) \leq 6$	-6.7	for	$0 < \phi N_{u,x} (\phi M_{u,y}) \leq 26.4$	-8.1
	for	$6 < \phi N_{u,x} (\phi M_{u,y}) < 14.2$	$-1/3 (26.3 - \phi N_{u,x} (\phi M_{u,y}))$	for	$26.4 < \phi N_{u,x} (\phi M_{u,y}) < 33.6$	$-1/3 (50.7 - \phi N_{u,x} (\phi M_{u,y}))$
	for	14.2	-4	for	33.6	-5.7

#### Notes on design

- $N_{u,x} (M_{u,y}) = M_{u,y} / a$
- a [m] or [inch]: Lever arm (separation between tension loaded and compression loaded threaded rods).
- Minimum lever arm a = 50 mm [2"] (without insulation spacers and after cutting insulation element to size see page 8)
- If the lifting loads for the Schöck Isokorb® T Type are relevant then the reverse is recommended, T Type S-V arranged above and T Type S-N arranged below.
- The load case presented here (negative shear force and positive moment) for the same connection can be combined with load case presented previously (positive shear force and negative moment).



## Design shear force and moment

### Positive and negative shear force $\phi V_{n,z}$ and negative and positive moment $\phi M_{n,y}$ - 2 modules Schöck Isokorb® T Type S-V

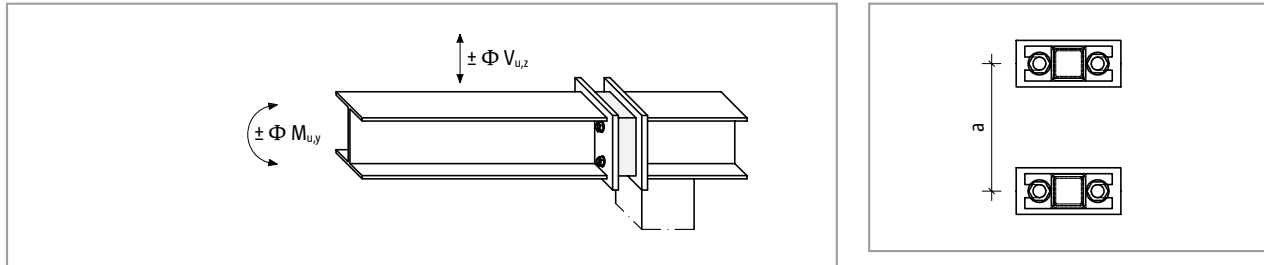

Schöck Isokorb® T type S-V 2.0	2 × S-V-D16		2 × S-V-D22		
Design value per	$\phi M_{n,y}$ [kNm/connection]				
Connection	$\pm 116.8 \cdot a$		$\pm 225.4 \cdot a$		
Shear force compression zone					
Module	$\phi V_{n,z}$ [kN/module]				
	$\pm 46$		$\pm 50$		
Shear force tension zone					
Module	$\phi V_{n,z}$ [kN/module]				
for	$0 < \phi P_{u,x} (\phi M_{u,y}) \leq 26.8$	$\pm 30$	for	$0 < \phi P_{u,x} (\phi M_{u,y}) \leq 117.4$	$\pm 36$
for	$26.8 < \phi P_{u,x} (\phi M_{u,y}) < 116.8$	$\pm 1/3 (116.8 - \phi N_{u,x} (\phi M_{u,y}))$	for	$117.4 <  \phi P_{u,x} (\phi M_{u,y})  \leq 225.4$	$\pm 1/3 (225.4 - \phi P_{u,x} (\phi M_{u,y}))$

Schöck Isokorb® T type S-V 2.0	2 × S-V-D16		2 × S-V-D22		
Design value per	$\phi M_{n,y}$ [kip.ft/connection]				
Connection	$\pm 26.3 \cdot a$		$\pm 50.7 \cdot a$		
Shear force compression zone					
Module	$\phi V_{n,z}$ [kip/Modul]				
	$\pm 10.3$		$\pm 11.2$		
Shear force tension zone					
Module	$\phi V_{n,z}$ [kip/Modul]				
for	$0 < \phi P_{u,x} (\phi M_{u,y}) \leq 6$	$\pm 6.7$	for	$0 < \phi N_{u,x} (\phi M_{u,y}) \leq 26.4$	$\pm 8.1$
for	$6 < \phi N_{u,x} (\phi M_{u,y}) < 26.3$	$\pm 1/3 (26.3 - \phi N_{u,x} (\phi M_{u,y}))$	for	$26.4 <  \phi N_{u,x} (\phi M_{u,y})  \leq 50.7$	$\pm 1/3 (50.7 - \phi P_{u,x} (\phi M_{u,y}))$

#### **i** Notes on design

- $\phi P_{u,x} (\phi M_{u,y}) = \phi M_{u,y} / a$
- $a$  [m] or [inch]: Lever arm (separation between tension loaded and compression loaded threaded rods).
- Minimum lever arm  $a = 50 \text{ mm}$  [2"] (without insulation spacers and after cutting insulation element to size see page 8)

## Design normal force, shear force and moment

Normal force  $\phi P_{n,x}$  and shear force  $\phi V_{n,z}$ ,  $\phi V_{n,y}$  and moments  $\phi M_{n,y}$ ,  $\phi M_{n,z}$  - 2 x Schöck Isokorb® T Type S-V

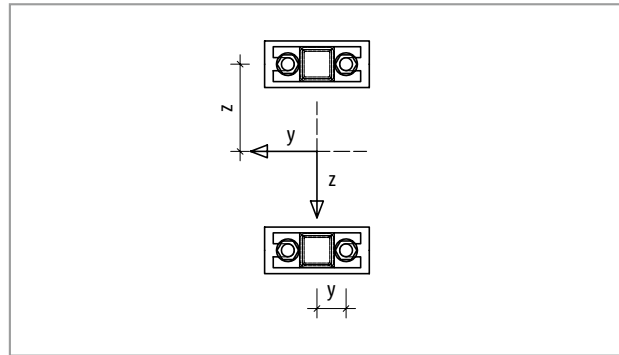
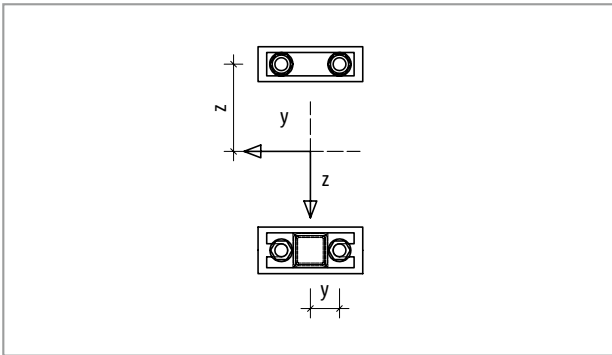
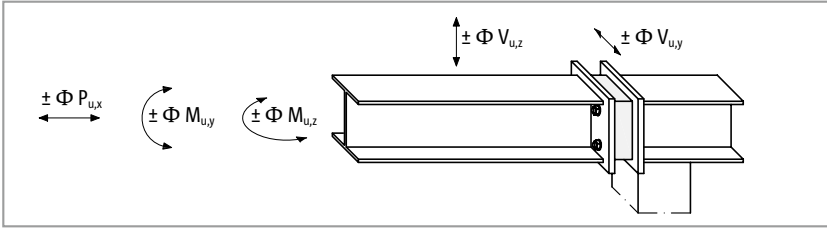

Allowable normal force  $\phi P_{n,x}$  per threaded rod, allowable moments  $\phi M_{n,y}$ ,  $\phi M_{n,z}$  per connection

Schöck Isokorb® T type	S-N-D16	S-N-D22	S-V-D16	S-V-D22
Design value per	$\phi P_{n,bolt}$ [kN/threaded rod]			
Threaded rod	+58.4/-31.7	+112.7/-74.8	±58.4	±112.7
	$\phi P_{n,Mz,bolt}$ [kN/threaded rod]			
	±29.2	±56.3	±29.2	±56.3

Schöck Isokorb® T type	S-N-D16	S-N-D22	S-V-D16	S-V-D22
Design value per	$\phi P_{n,bolt}$ [kip/threaded rod]			
Threaded rod	+13.2/-7.1	+25.3/-16.8	±13.1	±25.3
	$\phi P_{n,Mz,bolt}$ [kip/threaded rod]			
	±6.5	±12.6	±6.5	±12.6

**Algebraic sign definition**  
 $+\phi P_{n,bolt}$ : Threaded rod is in tension.  
 $-\phi P_{n,bolt}$ : Threaded rod is in compression.

Each threaded rod is loaded by a normal force  $P_{u,bolt}$ . This is made up of 3 subcomponents.

### Subcomponents

from normal force  $P_{u,x}$ :  $P_{u,1,bolt} = P_{u,x} / 4$   
 from moment  $M_{u,y}$ :  $P_{u,2,bolt} = \pm M_{u,y} / (4 \cdot z)$   
 from moment  $M_{u,z}$ :  $P_{u,3,bolt} = \pm M_{u,z} / (4 \cdot y)$

**Condition 1:**  $|P_{u,1,bolt} + P_{u,2,bolt} + P_{u,3,bolt}| \leq |\phi P_{n,bolt}|$  [kN/threaded rod]  
 The maximum or minimum loaded threaded rod is critical.

**Condition 2:**  $|P_{u,1,bolt} + P_{u,3,bolt}| \leq |\phi P_{n,Mz,bolt}|$  [kN/threaded rod]

## Design normal force, shear force and moment

### Allowable shear force per module and per connection

Schöck Isokorb® T type	S-V-D16				S-V-D22			
Design value per	Shear force compression zone							
Module	$\phi V_{i,n,z}$ [kN/module]							
	$\pm(46 -  \phi V_{i,u,y} )$				$\pm(50 -  \phi V_{i,u,y} )$			
	$\phi V_{i,n,y}$ [kN/module]							
	$\pm \min \{23; 46 -  \phi V_{i,u,z} \}$				$\pm \min \{25; 50 -  \phi V_{i,u,z} \}$			
Shear force tension zone/compression and tension								
Module	$\phi V_{i,n,z}$ [kN/module]							
	for	$0 < \phi P_{i,u,bolt} \leq 13.4$	$\pm(30 -  \phi V_{i,u,y} )$		for	$0 < \phi P_{i,u,bolt} \leq 58.7$	$\pm(36 -  \phi V_{i,u,y} )$	
	for	$13.4 < \phi P_{i,u,bolt} \leq 58.4$	$\pm 2/3 (58.4 - \phi P_{i,u,bolt}) -  \phi V_{i,u,y} $		for	$58.7 < \phi P_{i,u,bolt} \leq 112.7$	$\pm 2/3 (112.7 - \phi P_{i,u,bolt}) -  \phi V_{i,u,y} $	
	$\phi V_{i,n,y}$ [kN/module]							
	for	$0 < \phi P_{i,u,bolt} \leq 13.4$	$\pm \min \{23; 30 -  \phi V_{i,u,z} \}$		for	$0 < \phi P_{i,u,bolt} \leq 58.7$	$\pm \min \{25; 36 -  \phi V_{i,u,z} \}$	
	for	$13.4 < \phi P_{i,u,bolt} \leq 58.4$	$\pm \min \{23; 2/3 (58.4 - \phi P_{i,u,bolt}) -  \phi V_{i,u,z} \}$		for	$58.7 < \phi P_{i,u,bolt} \leq 112.7$	$\pm \min \{25; 2/3 (112.7 - \phi P_{i,u,bolt}) -  \phi V_{i,u,z} \}$	

Schöck Isokorb® T type	S-V-D16				S-V-D22			
Design value per	Shear force compression zone							
Module	$\phi V_{i,n,z}$ [kip/module]							
	$\pm(10.3 -  \phi V_{i,u,y} )$				$\pm(11.2 -  \phi V_{i,u,y} )$			
	$\phi V_{i,n,y}$ [kip/module]							
	$\pm \min \{5.2; 10.3 -  \phi V_{i,u,z} \}$				$\pm \min \{5.6; 11.2 -  \phi V_{i,u,z} \}$			
Shear force tension zone/compression and tension								
Module	$\phi V_{i,n,z}$ [kip/module]							
	for	$0 < \phi P_{i,u,bolt} \leq 3$	$\pm(6.7 -  \phi V_{i,u,y} )$		for	$0 < \phi P_{i,u,bolt} \leq 13.2$	$\pm(8.1 -  \phi V_{i,u,y} )$	
	for	$3 < \phi P_{i,u,bolt} \leq 13.1$	$\pm 2/3 (13.1 - \phi P_{i,u,bolt}) -  \phi V_{i,u,y} $		for	$13.2 < \phi P_{i,u,bolt} \leq 25.3$	$\pm 2/3 (25.3 - \phi P_{i,u,bolt}) -  \phi V_{i,u,y} $	
	$\phi V_{i,n,y}$ [kip/module]							
	for	$0 < \phi P_{i,u,bolt} \leq 3$	$\pm \min \{5.2; 6.7 -  \phi V_{i,u,z} \}$		for	$0 < \phi P_{i,u,bolt} \leq 13.2$	$\pm \min \{5.6; 8.1 -  \phi V_{i,u,z} \}$	
	for	$3 < \phi P_{i,u,bolt} \leq 13.1$	$\pm \min \{5.2; 2/3 (13.1 - \phi P_{i,u,bolt}) -  \phi V_{i,u,z} \}$		for	$13.2 < \phi P_{i,u,bolt} \leq 25.3$	$\pm \min \{5.6; 2/3 (25.3 - \phi P_{i,u,bolt}) -  \phi V_{i,u,z} \}$	

S

Products

## Design normal force, shear force and moment

**Determination of the effective normal force  $P_{i,u,bolt}$  per threaded rod**

$$P_{i,u,bolt} = P_{u,x} / 4 \pm |M_{u,y}| / (4 \cdot z) \pm |M_{u,z}| / (4 \cdot y)$$

Determination of the allowable shear force per Schöck Isokorb® T Type S-V module

The allowable shear force per Schöck Isokorb® T type S-V depends on the load on the threaded rods.

Zones are defined for this purpose:

<b>Compression:</b>	Both threaded rods are subjected to compression.
<b>Compression/tension:</b>	One threaded rod is subjected to compression, the other is subjected to tension.
<b>Tension:</b>	Both threaded rods are tension loaded.

(In the area, compression/tension and in the tension area the maximum positive normal force  $+P_{i,u,bolt}$  is to be applied in the design table)

$\phi V_{i,n,z}$ : Allowable shear force in the z-direction of the individual Schöck Isokorb® T Type S-V module independent on  $+P_{i,u,bolt}$  in the respective module i.

$\phi V_{i,n,y}$ : Allowable shear force in the y-direction of the individual Schöck Isokorb® T Type S-V module, depending on  $+P_{i,u,bolt}$  in the respective module i.

Determine  $\phi V_{i,n,z}$

Determine  $\phi V_{i,n,y}$

The vertical shear force  $V_{u,z}$  and the horizontal shear force  $V_{u,y}$  are in the ratio  $V_{u,z} / V_{u,y} = \text{constant}$  distributed on the individual Schöck Isokorb® T Type S-V.

**Condition:**  $V_{u,z} / V_{u,y} = \phi V_{i,n,z} / \phi V_{i,n,y} = \phi V_{n,z} / \phi V_{n,y}$

If this condition is not met,  $\phi V_{i,n,z}$  oder  $\phi V_{i,n,y}$  is reduced, so that the ratio is maintained.

**Verification:**  $V_{u,z} \leq \sum \phi V_{i,n,z}$

$$V_{u,y} \leq \sum \phi V_{i,n,y}$$

### **i** Design

- The design software is available for a rapid and efficient design:  
[www.schoeck.com/resources/na](http://www.schoeck.com/resources/na)
- Further information can be requested from the Technical Design Department.

## Design normal force, shear force and moment

Normal force  $\phi P_{n,x}$  and shear force  $\phi V_{n,z}$ ,  $\phi V_{n,y}$  and moments  $\phi M_{n,y}$ ,  $\phi M_{n,z}$  - n x T Type S-V

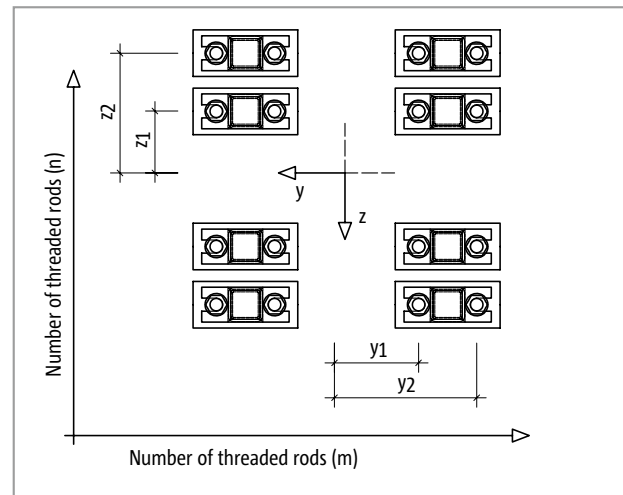
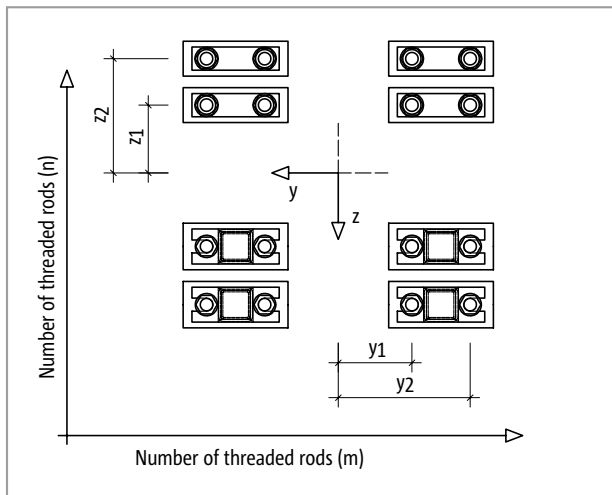
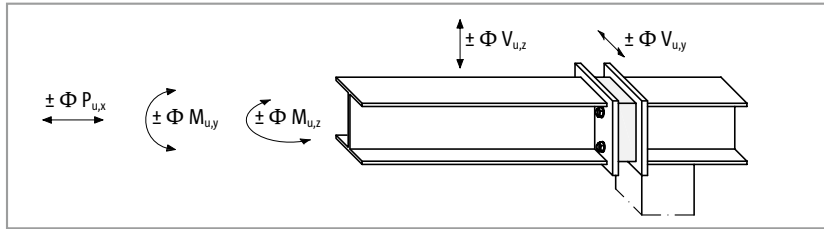

Allowable normal force  $\phi P_{n,x}$  per threaded rod, allowable moments  $\phi M_{n,y}$ ,  $\phi M_{n,z}$  per connection

Schöck Isokorb® T type	S-N-D16	S-N-D22	S-V-D16	S-V-D22
Design value per	$\phi P_{n,bolt}$ [kN/threaded rod]			
Threaded rod	+58.4/-31.7	+112.7/-74.8	±58.4	±112.7
	$\phi P_{n,Mz,bolt}$ [kN/threaded rod]			
	±29.2	±56.3	±29.2	±56.3

Schöck Isokorb® T type	S-N-D16	S-N-D22	S-V-D16	S-V-D22
Design value per	$\phi P_{n,bolt}$ [kip/threaded rod]			
Threaded rod	+13.2/-7.1	+25.3/-16.8	±13.1	±25.3
	$\phi P_{n,Mz,bolt}$ [kip/threaded rod]			
	±6.5	±12.6	±6.5	±12.6

## Design normal force, shear force and moment

**Algebraic sign definition**

$+\phi P_{n,bolt}$ : Threaded rod is in tension.  
 $-\phi P_{n,bolt}$ : Threaded rod is in compression.

m: Number of threaded rods per connection in z-direction  
n: Number of threaded rods per connection in y-direction

Each threaded rod is loaded by a normal force  $P_{u,bolt}$ . This is made up of 3 subcomponents.

### Subcomponents

from normal force  $P_{u,x}$ :  $P_{u,1,bolt} = P_{u,x} / m \cdot n$   
from moment  $M_{u,y}$ :  $P_{u,2,bolt} = \pm M_{u,y} / (2 \cdot m \cdot z_2 + 2 \cdot m \cdot z_1 / z_2 \cdot z_1)$   
from moment  $M_{u,z}$ :  $P_{u,3,bolt} = \pm M_{u,z} / (2 \cdot n \cdot y_2 + 2 \cdot n \cdot y_1 / y_2 \cdot y_1)$

**Condition 1:**  $|P_{u,1,bolt} + P_{u,2,bolt} + P_{u,3,bolt}| \leq |\phi P_{n,bolt}|$  [kN/threaded rod]  
The maximum or minimum loaded threaded rod is critical.

**Condition 2:**  $|P_{u,1,bolt} + P_{u,3,bolt}| \leq |\phi P_{n,Mz,bolt}|$  [kN/threaded rod]

## Design normal force, shear force and moment

### Allowable shear force per module and per connection

Schöck Isokorb® T type	S-V-D16				S-V-D22			
Design value per	Shear force compression zone							
Module	$\phi V_{i,n,z}$ [kN/module]							
	$\pm(46 -  \phi V_{i,u,y} )$				$\pm(50 -  \phi V_{i,u,y} )$			
	$\phi V_{i,n,y}$ [kN/module]							
	$\pm \min \{23; 46 -  \phi V_{i,u,z} \}$				$\pm \min \{25; 50 -  \phi V_{i,u,z} \}$			
Shear force tension zone/compression and tension								
Module	$\phi V_{i,n,z}$ [kN/module]							
	for	$0 < \phi P_{i,u,bolt} \leq 13.4$	$\pm(30 -  \phi V_{i,u,y} )$		for	$0 < \phi P_{i,u,bolt} \leq 58.7$	$\pm(36 -  \phi V_{i,u,y} )$	
	for	$13.4 < \phi P_{i,u,bolt} \leq 58.4$	$\pm 2/3 (58.4 - \phi P_{i,u,bolt}) -  \phi V_{i,u,y} $		for	$58.7 < \phi P_{i,u,bolt} \leq 112.7$	$\pm 2/3 (112.7 - \phi P_{i,u,bolt}) -  \phi V_{i,u,y} $	
	$\phi V_{i,n,y}$ [kN/module]							
	for	$0 < \phi P_{i,u,bolt} \leq 13.4$	$\pm \min \{23; 30 -  \phi V_{i,u,z} \}$		for	$0 < \phi P_{i,u,bolt} \leq 58.7$	$\pm \min \{25; 36 -  \phi V_{i,u,z} \}$	
	for	$13.4 < \phi P_{i,u,bolt} \leq 58.4$	$\pm \min \{23; 2/3 (58.4 - \phi P_{i,u,bolt}) -  \phi V_{i,u,z} \}$		for	$58.7 < \phi P_{i,u,bolt} \leq 112.7$	$\pm \min \{25; 2/3 (112.7 - \phi P_{i,u,bolt}) -  \phi V_{i,u,z} \}$	

Schöck Isokorb® T type	S-V-D16				S-V-D22			
Design value per	Shear force compression zone							
Module	$\phi V_{i,n,z}$ [kip/module]							
	$\pm(10.3 -  \phi V_{i,u,y} )$				$\pm(11.2 -  \phi V_{i,u,y} )$			
	$\phi V_{i,n,y}$ [kip/module]							
	$\pm \min \{5.2; 10.3 -  \phi V_{i,u,z} \}$				$\pm \min \{5.6; 11.2 -  \phi V_{i,u,z} \}$			
Shear force tension zone/compression and tension								
Module	$\phi V_{i,n,z}$ [kip/module]							
	for	$0 < \phi P_{i,u,bolt} \leq 3$	$\pm(6.7 -  \phi V_{i,u,y} )$		for	$0 < \phi P_{i,u,bolt} \leq 13.2$	$\pm(8.1 -  \phi V_{i,u,y} )$	
	for	$3 < \phi P_{i,u,bolt} \leq 13.1$	$\pm 2/3 (13.1 - \phi P_{i,u,bolt}) -  \phi V_{i,u,y} $		for	$13.2 < \phi P_{i,u,bolt} \leq 25.3$	$\pm 2/3 (25.3 - \phi P_{i,u,bolt}) -  \phi V_{i,u,y} $	
	$\phi V_{i,n,y}$ [kip/module]							
	for	$0 < \phi P_{i,u,bolt} \leq 3$	$\pm \min \{5.2; 6.7 -  \phi V_{i,u,z} \}$		for	$0 < \phi P_{i,u,bolt} \leq 13.2$	$\pm \min \{5.6; 8.1 -  \phi V_{i,u,z} \}$	
	for	$3 < \phi P_{i,u,bolt} \leq 13.1$	$\pm \min \{5.2; 2/3 (13.1 - \phi P_{i,u,bolt}) -  \phi V_{i,u,z} \}$		for	$13.2 < \phi P_{i,u,bolt} \leq 25.3$	$\pm \min \{5.6; 2/3 (25.3 - \phi P_{i,u,bolt}) -  \phi V_{i,u,z} \}$	

S

Products

## Design normal force, shear force and moment

**Determination of the effective normal force  $P_{i,u,bolt}$  per threaded rod**

$$P_{i,u,bolt} = P_{u,x} / (m \cdot n) \pm |M_{u,y}| / (2 \cdot m \cdot z_2 + 2 \cdot m \cdot z_i / z_2 \cdot z_1) \pm |M_{u,z}| / (2 \cdot n \cdot y_2 + 2 \cdot n \cdot y_i / y_2 \cdot y_1)$$

Determination of the allowable shear force per Schöck Isokorb® T Type S-V module

The allowable shear force per Schöck Isokorb® T type S-V depends on the load on the threaded rods.

Zones are defined for this purpose:

<b>Compression:</b>	Both threaded rods are subjected to compression.
<b>Compression/tension:</b>	One threaded rod is subjected to compression, the other is subjected to tension.
<b>Tension:</b>	Both threaded rods are tension loaded.

(In the area, compression/tension and in the tension area the maximum positive normal force  $+P_{i,u,bolt}$  is to be applied in the design table)

$\phi V_{i,n,z}$ : Allowable shear force in the z-direction of the individual Schöck Isokorb® T Type S-V module independent on  $+P_{i,u,bolt}$  in the respective module i.

$\phi V_{i,n,y}$ : Allowable shear force in the y-direction of the individual Schöck Isokorb® T Type S-V module, depending on  $+P_{i,u,bolt}$  in the respective module i.

Determine  $\phi V_{i,n,z}$

Determine  $\phi V_{i,n,y}$

The vertical shear force  $V_{u,z}$  and the horizontal shear force  $V_{u,y}$  are in the ratio  $V_{u,z} / V_{u,y} = \text{constant}$  distributed on the individual Schöck Isokorb® T Type S-V.

**Condition:**  $V_{u,z} / V_{u,y} = \phi V_{i,n,z} / \phi V_{i,n,y} = \phi V_{n,z} / \phi V_{n,y}$

If this condition is not met,  $\phi V_{i,n,z}$  oder  $\phi V_{i,n,y}$  is reduced, so that the ratio is maintained.

**Verification:**  $V_{u,z} \leq \sum \phi V_{i,n,z}$

$$V_{u,y} \leq \sum \phi V_{i,n,y}$$

### **i** Design

- The design software is available for a rapid and efficient design:  
[www.schoeck.com/resources/na](http://www.schoeck.com/resources/na)
- Further information can be requested from the Technical Design Department.



## Deformation

### Deflection of Schöck Isokorb® Modul connection due to axial forces $P_{u,x}$

Tension zone:  $\Delta l_T = | + P_{u,x} | \cdot k_T$

Compression zone:  $\Delta l_C = | - P_{u,x} | \cdot k_C$

Stiffness constant in tension:  $k_T$

Stiffness constant in compression:  $k_C$

Schöck Isokorb® T type		S-N		S-V	
Reciprocal spring constant		Thread diameter			
		D16	D22	D16	D22
per	Zone	k [cm/kN]			
Module	Tension	$2.27 \cdot 10^{-4}$	$1.37 \cdot 10^{-4}$	$1.69 \cdot 10^{-4}$	$1.15 \cdot 10^{-4}$
	Compression	$1.33 \cdot 10^{-4}$	$0.69 \cdot 10^{-4}$	$0.40 \cdot 10^{-4}$	$0.29 \cdot 10^{-4}$

Schöck Isokorb® T type		S-N		S-V	
Reciprocal spring constant		Thread diameter			
		D16	D22	D16	D22
per	Zone	k [inch/kips]			
Module	Tension	$0.40 \cdot 10^{-4}$	$0.24 \cdot 10^{-4}$	$0.30 \cdot 10^{-4}$	$0.20 \cdot 10^{-4}$
	Compression	$0.23 \cdot 10^{-4}$	$0.12 \cdot 10^{-4}$	$0.07 \cdot 10^{-4}$	$0.05 \cdot 10^{-4}$

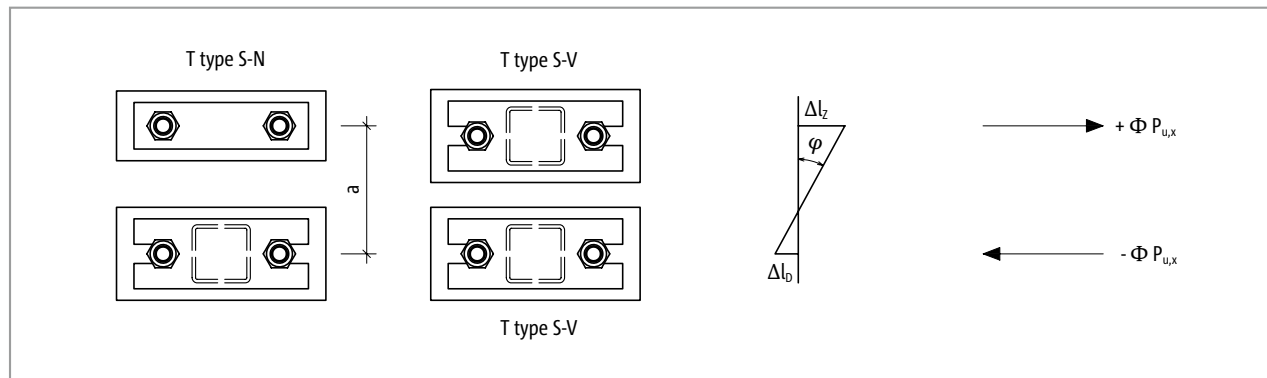

Fig. 27: Schöck Isokorb® T Type S-N + T Type S-V and 2 x T Type S-V: Deflection angle  $\varphi \approx \tan \varphi = (\Delta l_z + \Delta l_b) / a$

A moment  $M_{u,y}$  causes rotation of the Schöck Isokorb®. The deflection angle of the Schöck Isokorb® T Type S or a Schöck Isokorb® connection with 2 x T Type S-V modules can be given approximately as follows:

$$\varphi = M_{u,y} / C \text{ [rad]}$$

$\varphi$  [rad]

$M_{u,y}$  [kN·cm] oder [kip·inch]

$C$  [kN·cm/rad] oder [kip·inch/rad]

$a$  [cm] oder [inch]

deflection angle

characteristic moment for verification in the load case usability

torsion spring stiffness

lever arm

### Conditions

- End plate is infinitely stiff
- Load due to moment  $M_y$
- Deflection from shear force can be ignored
- In addition, deflections can result in the adjoining structural components.

## Deformation | Expansion Joint Spacing

Schöck Isokorb® T type	1 × S-N-D16 + 1 × S-V-D16	1 × S-N-D22 + 1 × S-V-D22	2 × S-V-D16	2 × S-V-D22
Torsion spring stiffness per	C [kN · cm/rad]			
Connection	$3700 \cdot a^2$	$6000 \cdot a^2$	$4700 \cdot a^2$	$6900 \cdot a^2$

Schöck Isokorb® T type	1 × S-N-D16 + 1 × S-V-D16	1 × S-N-D22 + 1 × S-V-D22	2 × S-V-D16	2 × S-V-D22
Torsion spring stiffness per	C [kip · inch/rad]			
Connection	$327 \cdot a^2$	$531 \cdot a^2$	$416 \cdot a^2$	$611 \cdot a^2$

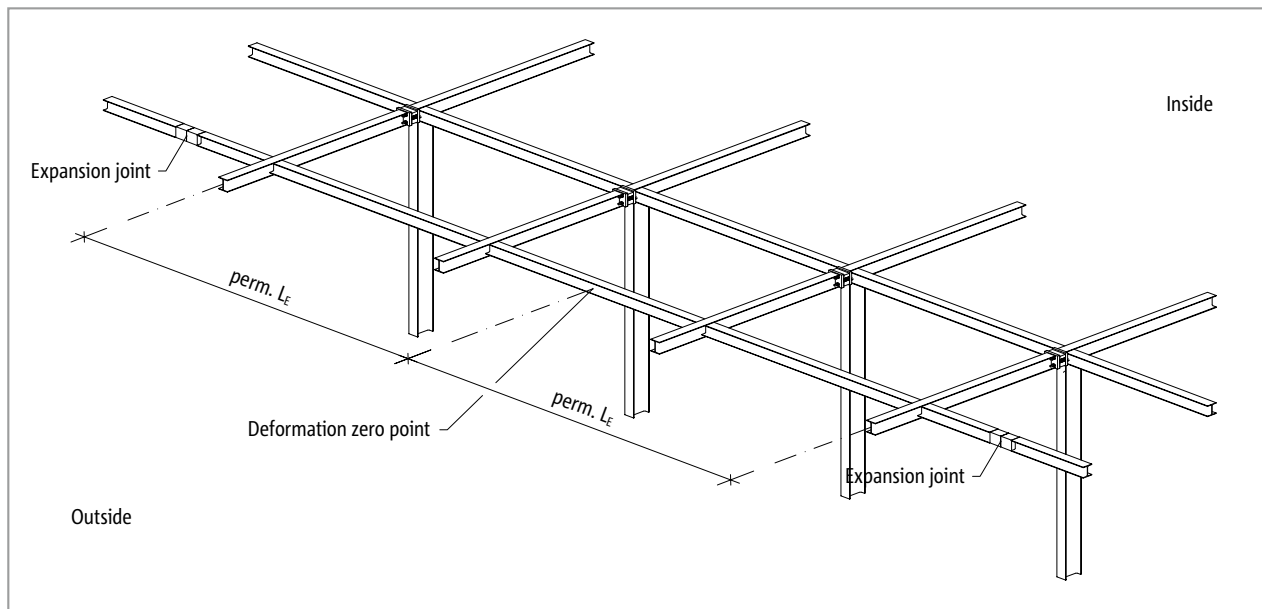

Fig. 28: Schöck Isokorb® T Type S: Example showing arrangement of expansion joints

Schöck Isokorb® T type	S-N, S-V
Permissible deformation length with	perm. $L_{\epsilon}$ [m]
Nominal hole tolerance [mm]	
2	5.24

Schöck Isokorb® T type	S-N, S-V
Permissible deformation length with	perm. $L_{\epsilon}$ [ft]
Nominal hole tolerance [inch]	
0.0787	17.19

## Implementation planning

### **i** Implementation planning

- To avoid installation errors it is recommended, besides the type designation of the selected modules, their colour code is also to be entered in the implementation plans:  
Schöck Isokorb® T Type S-N: white  
Schöck Isokorb® T Type S-V: blue
- The tightening torque of the nuts are also to be entered in the implementation plan; the following tightening torques apply:  
T Type S-N-D16, T Type S-V-D16 (threaded rod M16 - wrench width  $s = 24$  mm):  $M_t = 50$  Nm [37 lb-ft]  
T Type S-N-D22, T Type S-V-D22 (threaded rod M22 - wrench width  $s = 32$  mm):  $M_t = 80$  Nm [59 lb-ft]
- After tightening the nuts are to be peened over.
- The 4 Teflon sheets installed for each type S-V in use add approximately 4 mm [5/32"]. In particular with low balcony loading and with small centre-to-center distance between type S-N and type S-V, these additional 4 mm [5/32"] in the compression zone have an impact relevant to the camber of the steel beams connected with Schöck Isokorb®. Should shims be necessary for on-site levelling in the tension zone, this would be taken into account with the construction planning.

## Atmosphere containing chloride | Installation Instructions

For the protection against atmospheres containing chloride, e.g. in indoor swimming pools, special protective caps must be mounted on the building side, on the threaded rods of the Schöck Isokorb® T Type S. The Schöck Isokorb® T Type S-N and T Type S-V modules are installed according to static requirements and must be bolted together with the cap nuts on the inside.

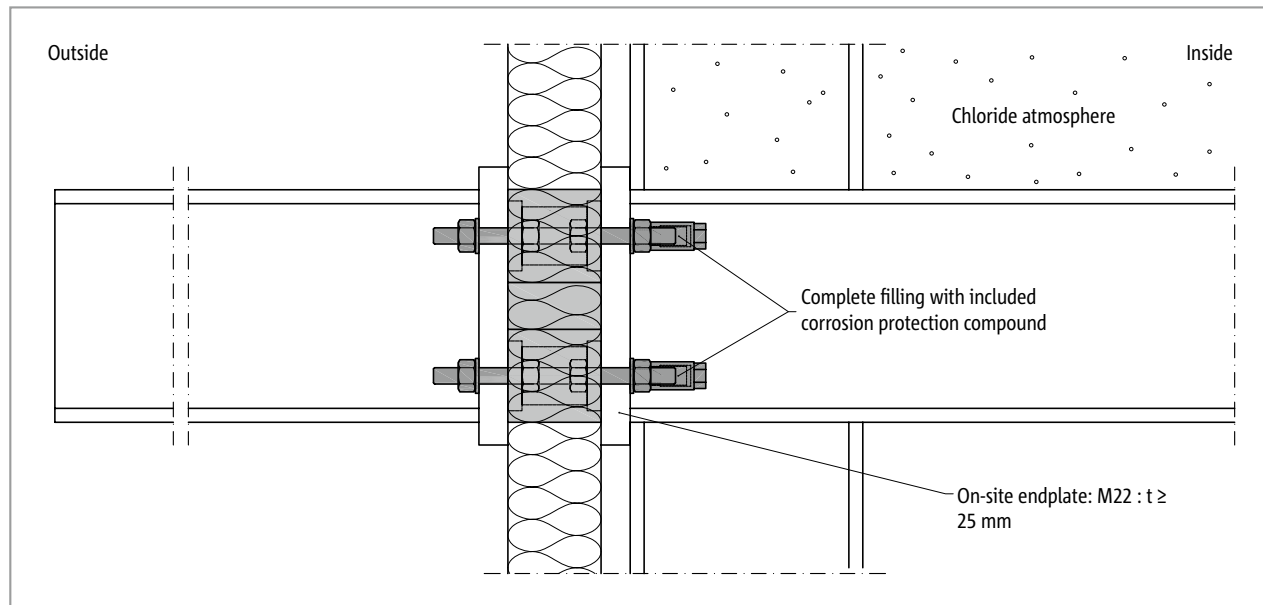

Fig. 29: Schöck Isokorb® T Type S with cap nuts: Cantilevered steel structure; internal atmosphere containing chloride

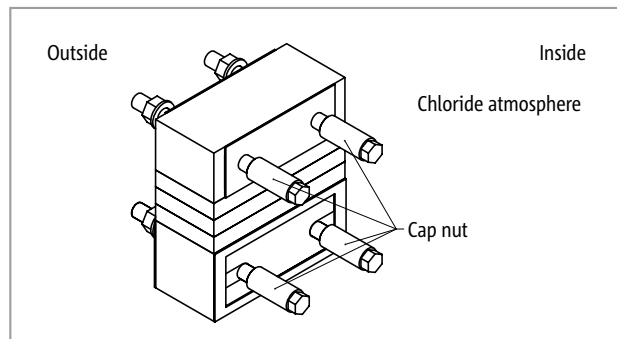

Fig. 30: Schöck Isokorb® T Type S with cap nuts: Isometric; internal atmosphere containing chloride

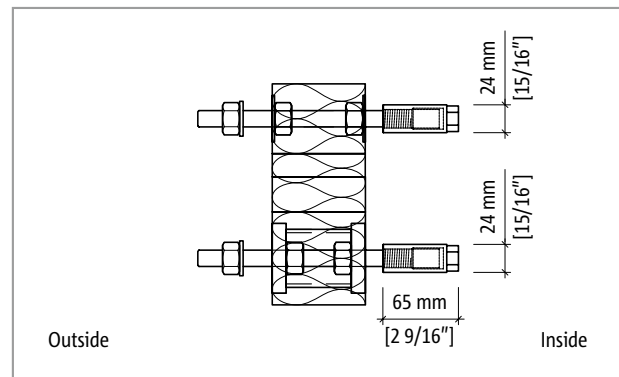

Fig. 31: Schöck Isokorb® Type S with cap nuts: Product section

- The protective caps must be completely filled with anti-corrosion sealant.
- Tighten protective caps hand tight without planned preloading, this corresponds with the following tightening torques  
T Type S-N-D16, T Type S-V-D16 (threaded rod M16):  $M_r = 50 \text{ Nm}$  [37 lb-ft]  
T Type S-N-D22, T Type S-V-D22 (threaded rod M22):  $M_r = 80 \text{ Nm}$  [59 lb-ft]
- The minimum thickness of the on site end plate is to be verified by the structural engineer.
- A certain minimum end plate thickness depending on the diameter of the threaded rods of the Schöck Isokorb® is necessary for environments containing chloride.

### **i** Installation instructions

The current installation instruction can be found online under:  
[www.schoeck.com/view/5184](http://www.schoeck.com/view/5184)

## ✓ Check List

- Is the Schöck Isokorb® element to be used under primarily static loads?
- Have the factored member forces on the Schöck Isokorb® connection been determined at design level?
- Has the additional deformation due to the Schöck Isokorb® been taken into account?
- Are temperature deformations assigned directly to the Schöck Isokorb® and with this is the maximum expansion joint spacing taken into account?
- Have the fire protection requirements for the overall load-bearing structure been clarified? Are the on-site measures included in the construction drawings?
- Are the Schöck Isokorb® T Type S-N and T Type S-V planned with protective caps in environments containing chloride (e.g. outside air near the sea, indoor swimming pools)?
- Are the names of the Schöck Isokorb® T Type S-N and T Type S-V entered in the implementation plan and in the working drawing?
- Is the colour code of the Schöck Isokorb® modules entered in the implementation plan and the construction drawing?
- Are the tightening torques for the screwed connections noted in the construction drawings?