

Public-law institution jointly founded by the  
federal states and the Federation

Technical authority granting approvals  
and permits for construction products  
and construction techniques

Date: 25 Nov 2021      Reference number:  
I 24-1.15.7-38/21

## National technical approval / General construction technique permit

**Number:**  
**Z-15.7-292**

**Applicant:**  
**Schöck Bauteile GmbH**  
Vimbucher Straße 2  
76534 Baden-Baden

**Validity**  
from: **25 November 2021**  
to: **31 August 2025**

**Subject of decision:**  
**Schöck Isokorb® T/XT types SK/SQ connecting steel girders to reinforced concrete slabs**

The subject named above is herewith granted a national technical approval (*allgemeine bauaufsichtliche Zulassung*) / general construction technique permit (*allgemeine Bauartgenehmigung*). This decision contains ten pages and 33 annexes with a total of 64 pages. This national technical approval / general construction technique permit replaces national technical approval / general construction technique permit no. Z-15.7-292 of 28 August 2020. The subject concerned was granted the first national technical approval on 5 August 2010.

**Translation authorised by DIBt**

DIBt

## I GENERAL PROVISIONS

- 1 This decision confirms the fitness for use and application of the subject concerned within the meaning of the Building Codes of the federal states (*Landesbauordnungen*).
- 2 This decision does not replace the permits, approvals and certificates required by law for carrying out construction projects.
- 3 This decision is granted without prejudice to the rights of third parties, in particular private property rights.
- 4 Notwithstanding further provisions in the 'Special Provisions', copies of this decision shall be made available to the user and installer of the subject concerned. The user and installer of the subject concerned shall also be made aware that this decision must be made available at the place of use or place of application. Upon request, copies shall also be provided to the authorities involved.
- 5 This decision may be reproduced in full only. Partial publication requires the consent of DIBt. Texts and drawings in promotional material shall not contradict this decision. In the event of a discrepancy between the German original and this authorised translation, the German version shall prevail.
- 6 This decision may be revoked. The provisions contained herein may subsequently be supplemented and amended, in particular if this is required by new technical findings.
- 7 This decision is based on the information and documents provided by the applicant. Alterations to this basis are not covered by this decision and shall be notified to DIBt without delay.

## II SPECIAL PROVISIONS

### 1 Subject concerned and field of use and application

This approval covers the 'Schöck Isokorb® T/XT types SK/SQ' connector types consisting of an 80 mm or 120 mm thick insulation layer and an arrangement of load-bearing steel bars to resist tensile, shear and compression forces.

In the area of the insulation joint and the directly adjacent steel concrete area, the tensile bars, shear bars and compression bars making up this arrangement of bars consist of steel with increased corrosion resistance in a section at least 10 cm in length.

Schöck Isokorb® T consists of an 80 mm thick insulation layer while the insulation layer of Schöck Isokorb® XT is 120 mm thick.

The following types exist (see Annex 1):

- Schöck Isokorb® T/XT type SK: tensile and compression bars or compression bearings to resist bending moments as well as tilted bars located in the insulation layer to resist shear forces and horizontal forces,
- Schöck Isokorb® T/XT type SQ: tilted bars located in the insulation layer as well as compression bearings to resist shear forces and horizontal forces.

The forces between the connected steel girders and reinforced concrete slabs are transferred through the screw connection or contact and the bond or butt joint to the adjacent components.

The bars located in the insulation layer to take up shear forces are usually tilted less than 45° in the longitudinal direction and less than 20° in the transverse direction for slab connections with an insulation thickness of 80 mm and less than 35° longitudinally and less than 20° transversely for slab connections with an insulation thickness of 120 mm.

The subject of the permit is the planning, design and execution of load-bearing thermal insulation elements to connect 18 to 28 cm thick reinforced concrete slabs in accordance with DIN EN 1992-1-1 in conjunction with DIN EN 1992-1-1/NA with a minimum concrete strength class C20/25 and a density between 2,000 kg/m<sup>3</sup> and 2,600 kg/m<sup>3</sup> under static or quasi-static loads.

### 2 Provisions for the construction product

#### 2.1 Properties and composition

##### 2.1.1 Dimensions

The permissible bar diameters for the tensile, compression and shear bars as well as the dimensions of the Schöck Isokorb® T/XT types SK/SQ are specified in Annexes 3 to 10 for the different types.

The minimum dimensions of the components to be connected and the edge distances and spacings for the design resistances specified in Annexes 11 to 16 and 19 to 25 shall comply with the information given in Annexes 17, 18, 26 and 27.

The bars shall not have any bends in the concrete-free area. The bends of the bars shall be started at a distance of at least  $2 \cdot \phi$  inside the concrete.

In the concrete-free area, the tensile and compression bars consist of stainless steel round bars and the shear bars of stainless steel reinforcing steel bars which are connected with a B500B reinforcing steel of the same nominal diameter by flash butt welding. In the concrete-free area, the shear bars can alternatively be made of stainless steel no. 1.4362 or 1.4482 as given in the data sheet.

The shear bars are connected with a forged bearing plate by flash butt welding (see Annexes 3 to 10).

Regarding the compression bar design, differentiation is made between two design variants for Schöck Isokorb® T/XT type SK-M1 or SK-MM1. The compression forces are transmitted either via the bond of the reinforcing steel or – in case this bar is not designed for transferring tensile forces – via a compression plate.

The compression plate consists of structural steel which is welded in a force-fitting manner to the compression bars on the bearing side of the connecting elements.

The modulus of elasticity of the compression bars shall be at least 160 000 N/mm<sup>2</sup>; this shall be verified via an inspection certificate 'type 3.1' in accordance with DIN EN 10204.

### 2.1.2 Materials

The following materials shall be used:

Reinforcing steel:	B500B in accordance with DIN 488-1
Structural steel:	S235JRG2 in accordance with DIN EN 10025-2 for the compression plates
Stainless steel:	Steel bar, material no. 1.4571, 1.4401, 1.4404, 1.4362 or 1.4462 of strength class S460 in accordance with Z-30.3-6 Steel bar, material no. 1.4362 of strength class S690 in accordance with national technical approval Z-30.3-6 for the tensile and compression bars B500B NR, material no. 1.4571 in accordance with national technical approval, B500A NR, material no. 1.4362 in accordance with national technical approval, B500B NR, material no. 1.4482 'Inoxripp 4486' in accordance with national technical approval and data sheet Bars, material no. 1.4362 or 1.4482 and the mechanical properties and surface properties in accordance with data sheet Steel, material no. 1.4571, 1.4401, 1.4404, 1.4462 or 1.4362 of strength class S460 in accordance with Z-30.3-6 for the forged bearing plates
Insulation product:	Rigid polystyrene foam (EPS) in accordance with DIN EN 13163 Mineral fibre insulation materials in accordance with DIN EN 13162 and data sheet

The concrete of the adjacent components shall at least correspond to strength class C20/25 (C25/30 for external components).

## 2.2 Manufacture, packaging, transport, storage and marking

### 2.2.1 Manufacture of welded connections

The welded connections are subject to the specifications of Z-30.3-6 in conjunction with DIN EN ISO 17660-1. If compression bars are manufactured with a compression plate made of structural steel, the plate shall be welded in a force-fitting manner to the compression bars on the bearing side of the connecting elements by means of a circumferential fillet weld or a butt weld. The bars shall be manufactured in a length to ensure that the steel compression plate is located 50 mm from the slab front side.

The welded joints connecting the forged bearing plate and the shear bars shall be produced as per the welding procedure specifications in accordance with the test plan.

### 2.2.2 Packaging and marking

The manufacturer shall mark every packaging unit of the Schöck Isokorb® connections in a durable and easily legible manner, e.g. using a sticker bearing the national conformity mark (*Ü-Zeichen*) in accordance with the Conformity Marking Ordinance (*Übereinstimmungszeichen-Verordnungen*) of the federal states. The mark shall only be applied if the requirements given in Section 2.3 are met.

In addition, the marking shall include at least the following information:

- approval number (Z-15.7-292)
- type designation.

Clear information regarding the installation of the connections and the connecting reinforcements shall be attached to every Schöck Isokorb®. The manufacturer shall supply an installation manual with every delivery.

## 2.3 Confirmation of conformity

### 2.3.1 General

The manufacturer shall confirm for each manufacturing plant that the Schöck-Isokorb® construction product complies with the provisions of this national technical approval by way of a declaration of conformity based on factory production control and a certificate of conformity issued by a certification body recognised for these purposes as well as on regular external surveillance carried out by a recognised inspection body in accordance with the following provisions: To issue the certificate of conformity and for external surveillance including the associated product testing, the applicant of the construction product shall use a certification body and an inspection body recognised for these purposes.

The declaration of conformity shall be submitted by the manufacturer through marking of the construction product with the national conformity mark including statement of the intended use.

The certification body shall send a copy of the certificate of conformity issued by it to DIBt.

A copy of the initial type-testing report shall also be sent to Deutsches Institut für Bautechnik.

### 2.3.2 Factory production control

A factory production control system shall be set up and implemented in each manufacturing plant. Factory production control shall be understood to be continuous surveillance of production by the manufacturer to ensure that the manufactured construction products satisfy the provisions of this national technical approval.

The factory production control shall at least include the following measures:

- Verification of the starting material and the components:

Only materials for which the verification of conformity in accordance with the current standards and approvals has been provided and which are marked in a corresponding manner or which have been monitored and tested in accordance with the provisions of this decision shall be used for the Schöck Isokorb®.

- Inspection and tests to be carried out during manufacture:

The properties of the bars shall be tested in accordance with the applicable approvals and standards as well as the test plans.

- Verifications and tests to be carried out on the finished construction product:

The dimensions of the Schöck Isokorb® construction product as well as the workmanship and post-treatment of the welded joints shall be checked for every Isokorb.

The results of factory production control shall be recorded and evaluated. The records shall at least include the following information:

- designation of the construction product or the starting material or the components,
- type of check or test,
- date of manufacture and testing of the construction product or the starting material or the components,
- Results of the checks and tests as well as, if applicable, comparison with the requirements,
- signature of the person responsible for factory production control.

The records shall be kept for at least five years. They shall be submitted to DIBt and the competent supreme building authority upon request.

If the test result is unsatisfactory, the manufacturer shall immediately take the necessary measures to resolve the defect. Construction products which do not meet the requirements shall be handled in such a way that they cannot be confused with compliant products. After the defect has been remedied, the relevant test shall be repeated immediately - where technically feasible and necessary to show that the defect has been eliminated.

### 2.3.3 External surveillance

The plant and the factory production control system shall be inspected regularly, i.e. at least twice a year, by means of external surveillance at each manufacturing plant. Initial type-testing of the construction product Schöck Isokorb® shall be carried out within the scope of external surveillance and samples for random testing shall also to be taken. Sampling and testing shall be the responsibility of the recognised inspection body.

Within the scope of review of factory production control, tests shall be carried out in accordance with the test plan and the results evaluated and compared with the requirements of the test plans.

The results of the certification and external surveillance shall be kept for at least five years. They shall be presented by the certification or inspection body to DIBt and the competent supreme building authority upon request.

## 3 Provisions for planning, design and execution

### 3.1 Planning and design

Unless otherwise specified below, DIN EN 1992-1-1 in conjunction with DIN EN 1992-1-1/NA shall apply to the planning and design.

#### 3.1.1 General

Depending on the type, Schöck Isokorb® connections may be used to transfer bending moments and/or shear forces as well as horizontal forces. The minimum strength class of the reinforced normal-strength concrete parts to be connected is C20/25 (C25/30 for external components).

The connected steel construction shall be divided by joints which are to be arranged in accordance with Section 3.2.1 to decrease the thermal stress. If structural measures regarding the movement of the coating of the connected steel construction are taken, the maximum temperature differences of the steel connection construction shall be decisive for the calculation of joint spacings.

The stresses occurring in the steel construction are transferred locally in the joint via the tension and compression members and are transmitted via a load introduction area in the connected slabs. Structural analysis of the transmission of the forces shall be carried out.

Loading of the connections due to local torsion moments shall be excluded. For this reason, at least two Schöck Isokorb® connection elements shall be applied for every construction to be connected.

If the slabs connected to the load-bearing thermal insulation elements are implemented as prefabricated concrete slabs, an in-situ concrete topping in accordance with Annex 33 shall be formed between the load-bearing thermal insulation element and the prefabricated concrete slab.

### 3.1.2 Resistance to fire

This decision does not verify the fitness for use of the Schöck Isokorb® in components for which fire resistance requirements apply.

### 3.1.3 Thermal insulation

For the assessment of thermal insulation, the following verifications shall be provided:

a) Assessment of risk of condensation (temperature drop below the condensation point)

The design calculations given in DIN 4108-2, Clause 6.2, shall be provided. The temperature factor shall be provided at the most unfavourable spot for the minimum requirement of  $f_{Rsi} \geq 0.7$  and  $\theta_{si} \geq 12.6$  °C in accordance with DIN EN ISO 10211.

b) Consideration of the increased transmission heat loss in accordance with DIN V 4108-6

If no more precise verification is performed, the slab connection may be viewed as a thermally isolated structure in the sense of DIN V 4108 suppl. 2. For this reason, a general specific heat bridge correction factor of  $\Delta U_{WB} = 0.05$  W/m<sup>2</sup> · K can be applied for the entire enclosed area.

### 3.1.4 Durability and corrosion protection

The requirements regarding durability are specified in DIN EN 1992-1-1, Clause 4. The minimum concrete strength classes as well as the minimum concrete cover depending on the respective environmental conditions shall be complied with in accordance with DIN EN 1992-1-1. Corrosion protection is ensured by compliance with the concrete cover of the on-site reinforcement in accordance with DIN EN 1992-1-1 and by using the materials in accordance with this decision.

### 3.1.5 Specifications for the insulation joint and the load introduction area for ultimate limit states

The design resistances are given in Annexes 11 to 16 and 19 to 25 and apply to the respective design sections 'A-A' shown therein. They apply to Schöck Isokorb® elements with good bond conditions in accordance with DIN EN 1992-1-1 and DIN EN 1992-1-1/NA Clause 8.4.2 with minimum edge distances as specified in Annexes 17 and 26 respectively in accordance with Annexes 18 and 27 respectively and which are installed with on-site connection reinforcements. The on-site reinforcement shall be arranged as specified in Annex 31 or 32; this applies to a nominal dimension of the concrete cover of 20 mm.

For uplifting shear forces as well as horizontal forces parallel to the insulation joint, the transmission of the loads between the on-site end plate and the compression bars shall be ensured in accordance with Annexes 11 to 15 and 19 to 24.

For horizontal forces perpendicular to the insulation joint  $Z_{\perp}$  or  $D_{\perp}$  the design resistances shall be determined in accordance with Annexes 16 or 25.



Tensile and fatigue strength verifications for axial forces and bending, resulting from deformation due to temperature differences of the components to be connected in terms of Section 3.1 of Z-30.3-6, do not need to be provided. Within the scope of the approval procedure, these verifications are considered to be provided through limitation of the joint spacings in the external structural components in accordance with Section 3.2.1.

The tensile and compression bars shall be connected with the tensile and compression bars of adjacent slabs. The lap lengths specified in Annexes 3 to 10 shall be maintained.

The shear bars shall be anchored with their straight legs in the slabs with the anchorage lengths specified in Annexes 3 to 10.

### **3.1.6 Special specifications in the area of the insulation joint and in the force introduction area for the verifications in the serviceability limit state**

For crack width control, DIN EN 1992-1-1 and DIN EN 1992-1-1/NA Clause 7.3.1. shall apply. An additional verification does not need to be provided at the frontal side of the joint or in the load introduction area if the provisions of this decision are complied with.

In the calculation of the vertical deformations at the leading edge of the steel construction, the deformations resulting from the torsion in the Schöck Isokorb® T/XT shall be considered for the cantilever connection. The verification of the deformations shall be provided under the quasi-continuous action combination. Depending on the type, the maximum rotation angle as specified in Table 22 in Annex 18 or Table 41 in Annex 27 may occur in the ultimate limit state as a result of the cantilever connection.

As far as an inspection of the vibration behaviour of the steel construction to be connected is required, the additional deformations resulting from the Schöck Isokorb® T/XT shall be considered.

## **3.2 Provisions for execution**

### **3.2.1 Spacings and joint spacings**

The required edge distance  $e_R$  of the Schöck Isokorb® in accordance with Annex 17 / Annex 26 shall be at least 30 mm. In accordance with Table 21 in Annex 17 and Table 40 in Annex 26, the shear force  $V_{Rd}$  shall be applied for edge distances  $e_R$  which are less than the values given in Table 21 in Annex 17 and Table 40 in Annex 26.

The spacing for Schöck Isokorb® T and for Schöck Isokorb® XT shall not be less than 230 mm and 260 mm respectively.

Expansion joints shall be placed at a right angle to the insulation layer in the external steel members in order to limit thermal stress. The permissible expansion joint spacing shall be taken from Table 23 in Annex 18 or Table 42 in Annex 27.

### **3.2.2 Detailing**

In the reinforced concrete slabs, the minimum concrete cover in accordance with DIN EN 1992-1-1 shall be complied with. This applies to tensile and compression bars, the lateral reinforcement or an existing installation reinforcement.

The reinforcement of the concrete structures connected to the cantilever connections shall be extended to the insulation layer in consideration of the required concrete cover in accordance with DIN EN 1992-1-1.

The transverse bars usually shall lie on top of the longitudinal bars of the Schöck Isokorb® connections. For bars with a nominal diameter of less than 16 mm an exception may be made if under the respective construction site conditions the installation of the transverse bars directly underneath the longitudinal bars of the Schöck Isokorb® connections is possible and monitored, e.g. by the construction supervisor. The necessary installation steps shall be described in the installation manual.



The required edge and splitting tensile reinforcement for the Schöck Isokorb® T/XT type SK-M1-V1 and type SK-M1-V2 as well as for all SQ types is covered through installation of two 8 mm U bars as shown in Annexes 30 and 33.

The on-site connection reinforcement shall be installed in accordance with Annex 31 or 32.

Sufficient distance between load-bearing thermal insulation elements and prefabricated concrete slabs shall be ensured (see Section 3.1.1 and Annex 33). The concrete composition of the in-situ concrete joint (maximum aggregate size  $d_g$ ) shall be matched with this distance.

The executing company shall provide a declaration of conformity in accordance with Section 16a(5) in conjunction with Section 21(2) of the Model Building Code to confirm conformity of the construction technique with the general construction technique permit included in this decision.

The following standards, approvals and references are referred to in this decision:

- DIN 488-1:2009-08 Reinforcing steels – Part 1: Grades, properties, marking
- DIN 4108-2:2013-02 Thermal protection and energy economy in buildings – Part 2: Minimum requirements for thermal insulation
- DIN 4108 Suppl. 2:2006-03 Thermal insulation and energy economy in buildings – Thermal bridges – Examples for planning and performance
- DIN V 4108-6:2003-06 Thermal protection and energy economy in buildings – Part 6: Calculation of annual heat and energy use + Corrigenda 1:2004-03
- DIN EN 1992-1-1:2011-01 + A1:2015-03  
Eurocode 2: Design of concrete structures – Part 1-1: General rules and rules for buildings; German version EN 1992-1-1:2004 + A1:2014 **and**  
DIN EN 1992-1-1/NA:2013-04 + A1:2015-12  
National Annex – Nationally determined parameters – Eurocode 2: Design of concrete structures – Part 1-1: General rules and rules for buildings
- DIN EN 10025-2:2019-10 Hot rolled products of structural steels – Part 2: Technical delivery conditions for non-alloy structural steels; German version EN 10025-2:2019
- DIN EN 10204:2005-01 Metallic products - Types of inspection documents; German version EN 10204:2004
- DIN EN 13162:2015-04 Thermal insulation products for buildings – Factory made mineral wool (MW) products – Specification; German version EN 13162:2012+A1:2015
- DIN EN 13163:2016-08 Thermal insulation products for buildings - Factory made expanded polystyrene (EPS) products - Specification; German version EN 13163:2012+A1:2015
- DIN EN ISO 10211:2018-03 Thermal bridges in building construction - Heat flows and surface temperatures - Detailed calculations (ISO 10211:2017); German version EN ISO 10211:2017
- DIN EN ISO 17660-1:2006-12 Welding - Welding of reinforcing steel – Part 1: Load-bearing welded joints (ISO 15660-1:2006); German version EN ISO 17660-1:2006

- Approval no. Z-30.3-6                      Products, components and fasteners made of stainless steels, dated 5 March 2018
- The data sheet is deposited with DIBt and the body used for external surveillance.
- The test plan is deposited with DIBt and the body used for external surveillance.

Beatrix Wittstock  
Head of Section

Drawn up by  
Kisan



Fig.1: Schöck Isokorb® T types SK-M1-V1 and SK-M1-V2



Fig.2: Schöck Isokorb® T type SK-MM1-VV1

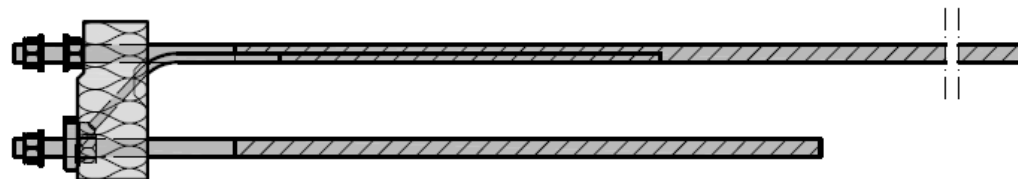

Fig.3: Schöck Isokorb® T types SK-MM2-VV1 and SK-MM2-VV2



Fig.4: Schöck Isokorb® T types SQ-V1, SQ-V2 and SQ-V3

*A comma is used as the decimal marker.*

Schöck Isokorb® T/XT types SK/SQ

T types SK/SQ connections

Annex 1



Fig.5: Schöck Isokorb® XT types SK-M1-V1 and SK-M1-V2



Fig.6: Schöck Isokorb® XT type SK-MM1-VV1

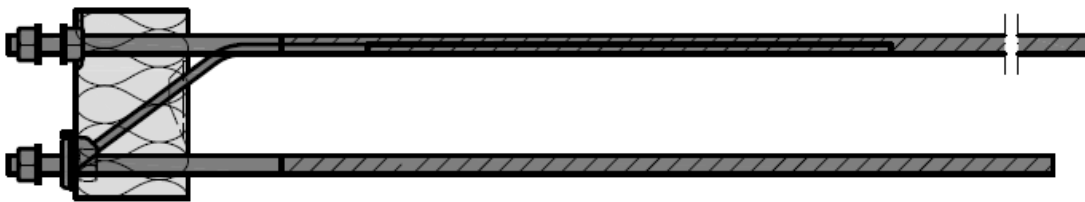

Fig.7: Schöck Isokorb® XT types SK-MM2-VV1 and SK-MM2-VV2

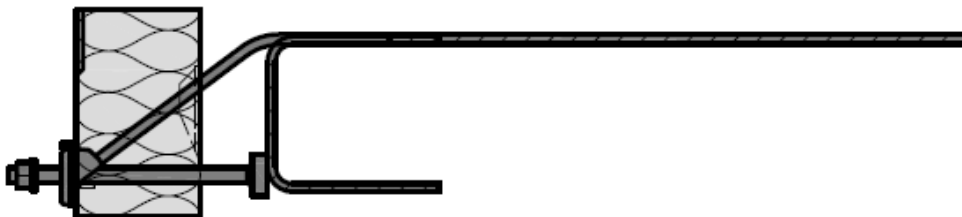

Fig.8: Schöck Isokorb® XT types SQ-V1, SQ-V2 and SQ-V3

Schöck Isokorb® T/XT types SK/SQ

XT types SK/SQ connections

Annex 2

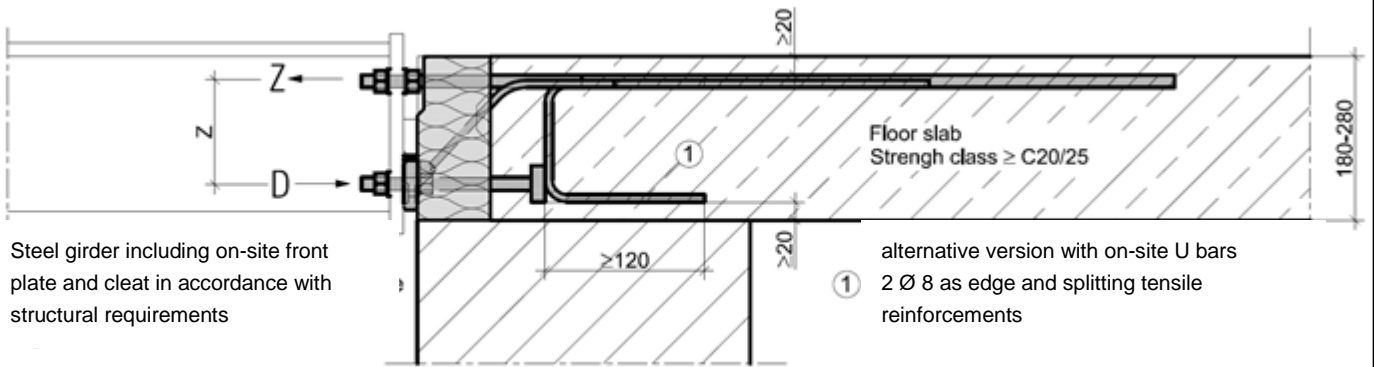

Fig.9: Schöck Isokorb® T types SK-M1-V1 and SK-M1-V2

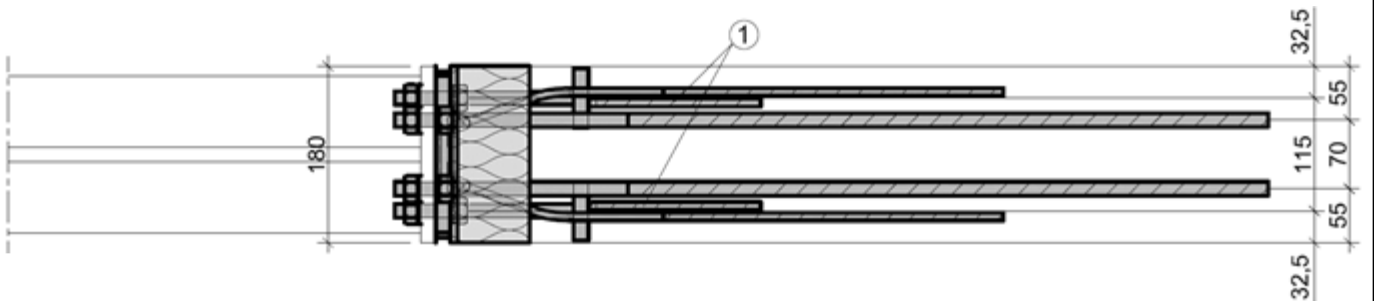

Fig.10: Plan



Fig.11: Tensile bars 2  $\varnothing 14$

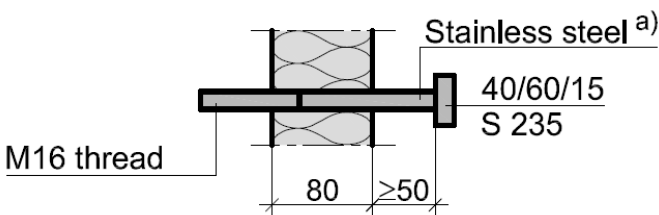

Fig. 12: Compression bearings 2  $\varnothing 14$

Schöck Isokorb® T/XT types SK/SQ

Dimensions for T types SK-M1-V1 and SK-M1-V2

Annex 3  
 Page 1/3

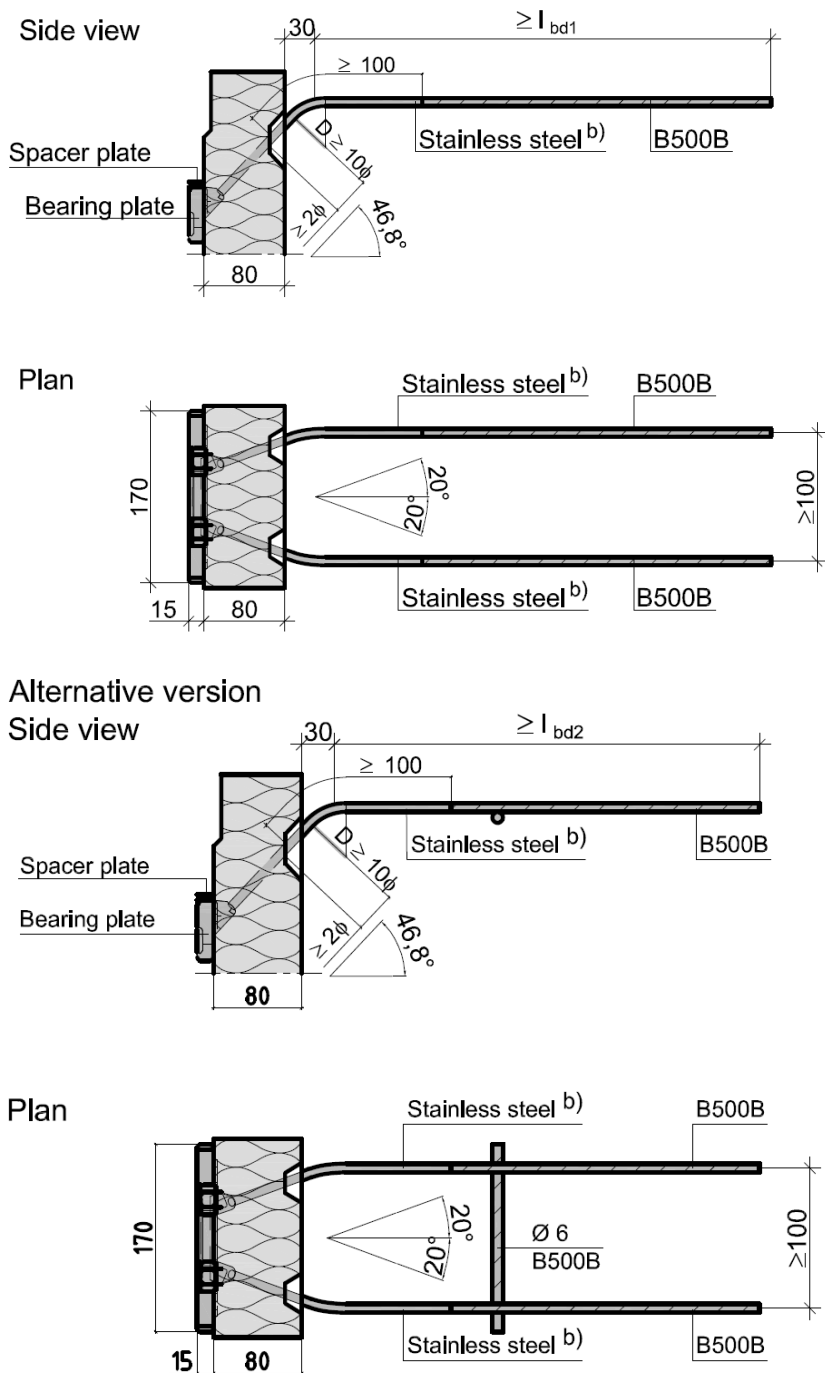

Fig.13a to 13d: Shear bars 2 Ø d incl. bearing plate

Schöck Isokorb® T/XT types SK/SQ

Dimensions for T types SK-M1-V1 and SK-M1-V2

Annex 3  
 Page 2/3

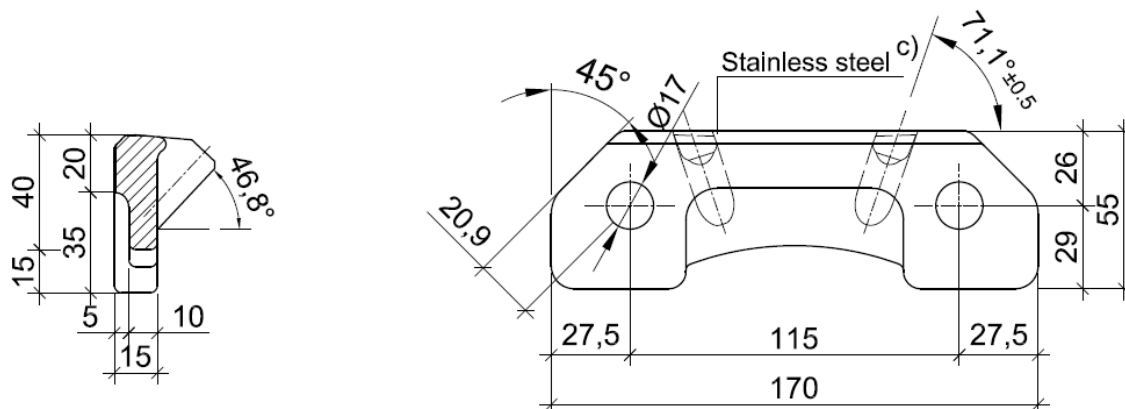

Fig.14: Bearing plate

Table 1: T type SK-M1 shear bars and anchorage lengths

Type	Shear bar	C20/25		Distribution bar
Load capacity	Quantity x d	$l_{bd1}$	$l_{bd2}$	Quantity x d
	[mm]	[mm]	[mm]	[mm]
T type SK-M1-V1	2 x 8	530	371	1 x 6
T type SK-M1-V2	2 x 10	662	463	1 x 6

a) b) c) See Section 2.1.2 for material specifications

Schöck Isokorb® T/XT types SK/SQ

Dimensions for T types SK-M1-V1 and SK-M1-V2

Annex 3  
 Page 3/3



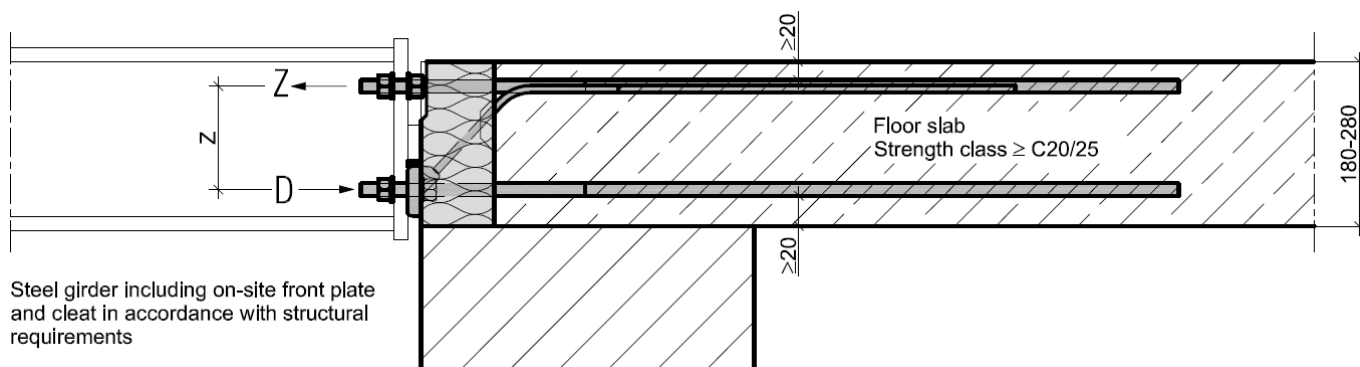

Fig. 15: Schöck Isokorb® T type SK-MM1-VV1

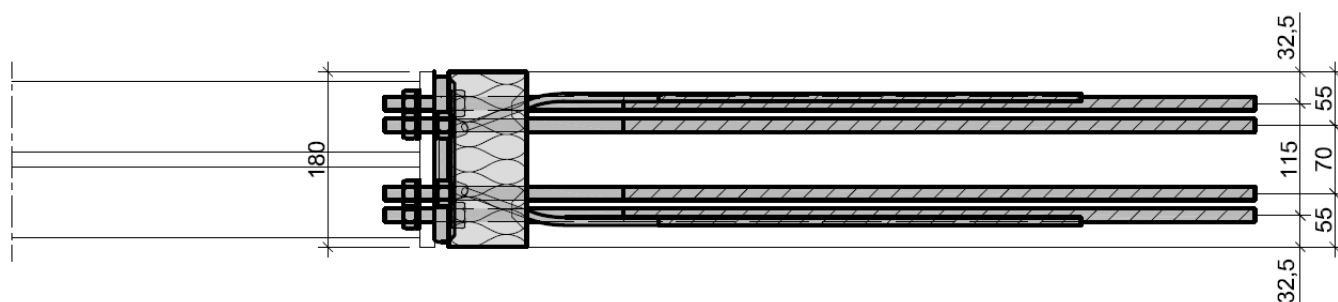

Fig. 16: Plan

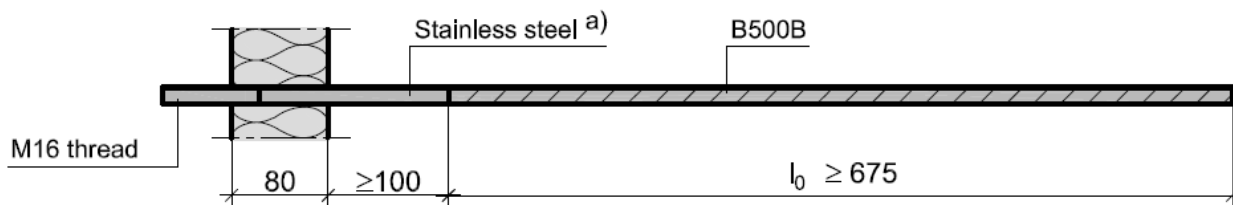

Fig. 17: Tensile and compression bars 2 x 2 Ø 14

Schöck Isokorb® T/XT types SK/SQ

Dimensions for T type SK-MM1-VV1

Annex 4  
 Page 1/3

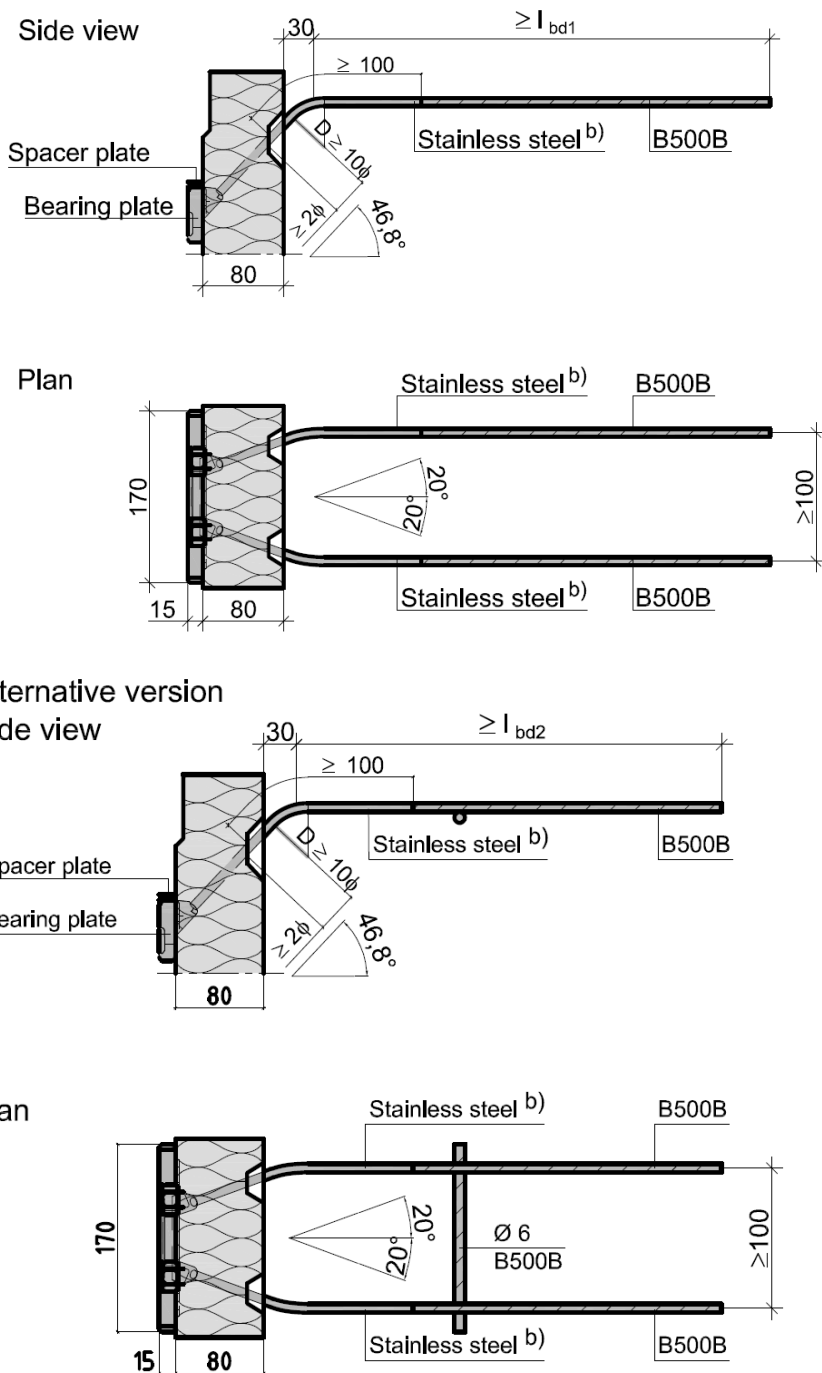

Fig.18a to 18d: Shear bars 2 Ø 8 incl. bearing plate

Schöck Isokorb® T/XT types SK/SQ

Dimensions for T type SK-MM1-VV1

Annex 4  
 Page 2/3

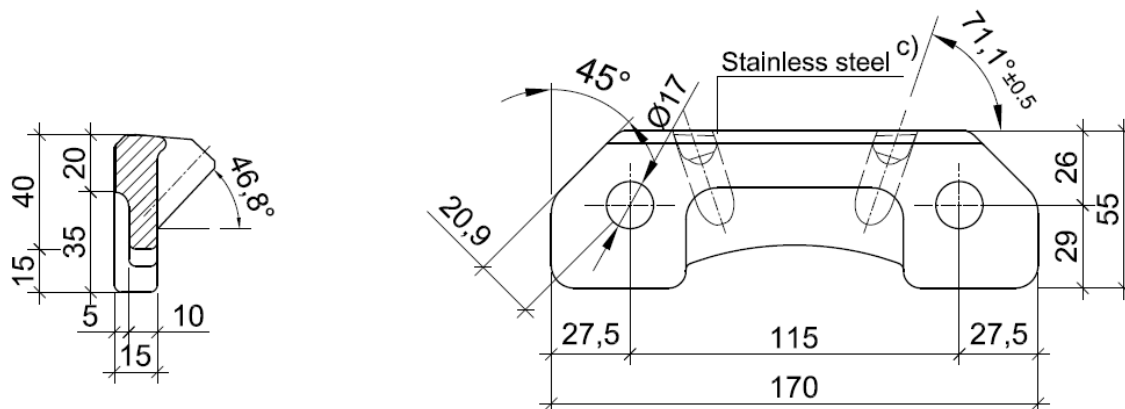

Fig.19: Bearing plate

Table 2: T type SK-MM1-VV1 shear bars and anchorage lengths

Type	Shear bar	C20/25		Distribution bar
Load capacity	Quantity x d	$l_{bd1}$	$l_{bd2}$	Quantity x d
	[mm]	[mm]	[mm]	[mm]
T type SK-MM1-VV1	2 x 8	530	371	1 x 6

a) b) c) See Section 2.1.2 for material specifications

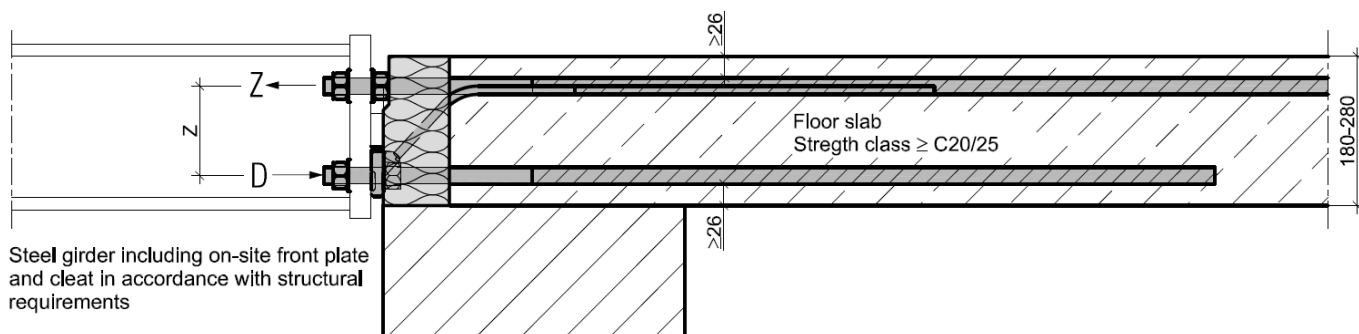

Fig.20: Schöck Isokorb® T types SK-MM2-VV1 and SK-MM2-VV2

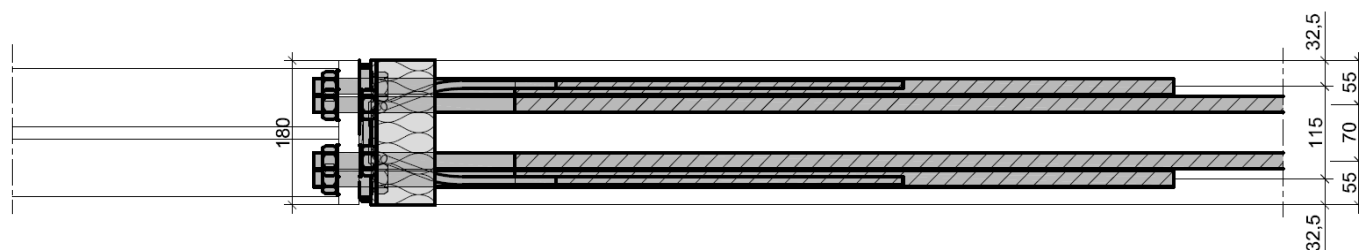

Fig.21: Plan

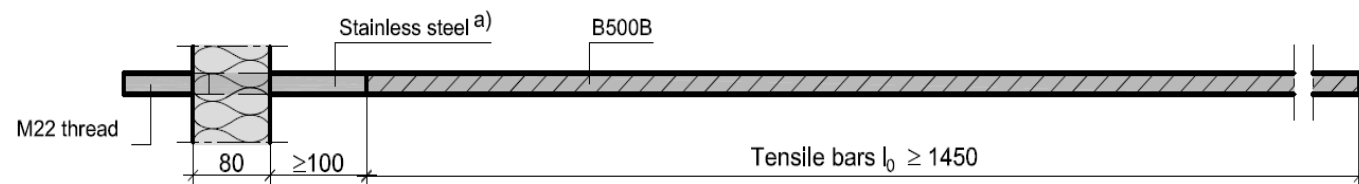

Fig.22: Tensile bars 2 Ø 20

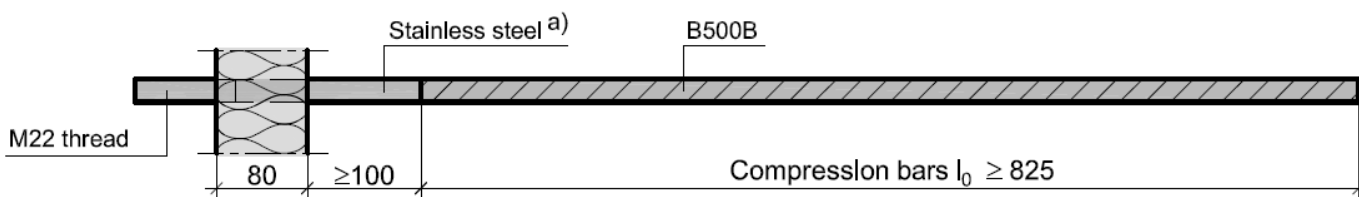

Fig.23: Compression bars 2 Ø 20

Schöck Isokorb® T/XT types SK/SQ

Dimensions for T types SK-MM2-VV1 and SK-MM2-VV2

Annex 5  
 Page 1/3

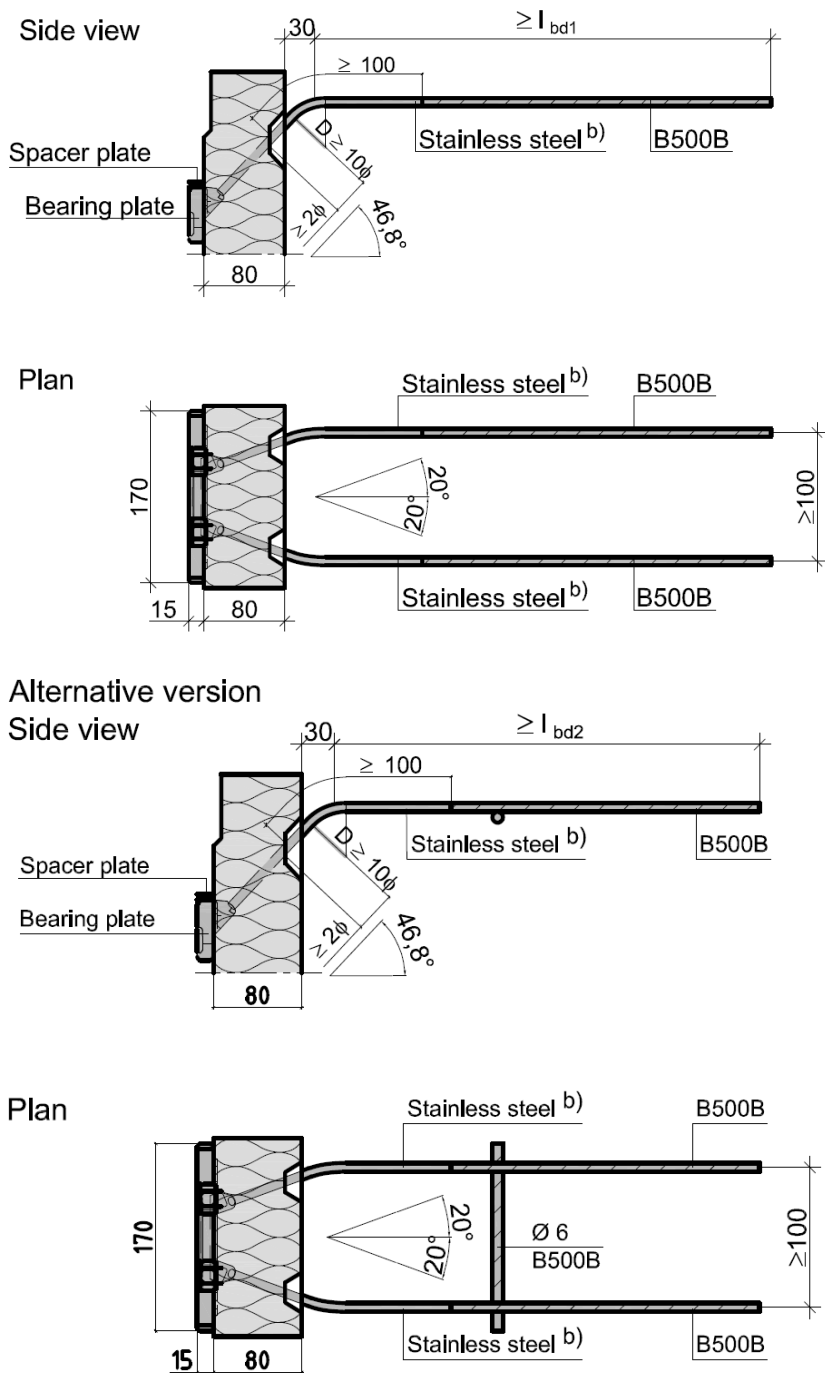

Fig.24a to 24d: Shear bars 2 Ø d incl. bearing plate

Schöck Isokorb® T/XT types SK/SQ

Dimensions for T types SK-MM2-VV1 and SK-MM2-VV2

Annex 5  
 Page 2/3

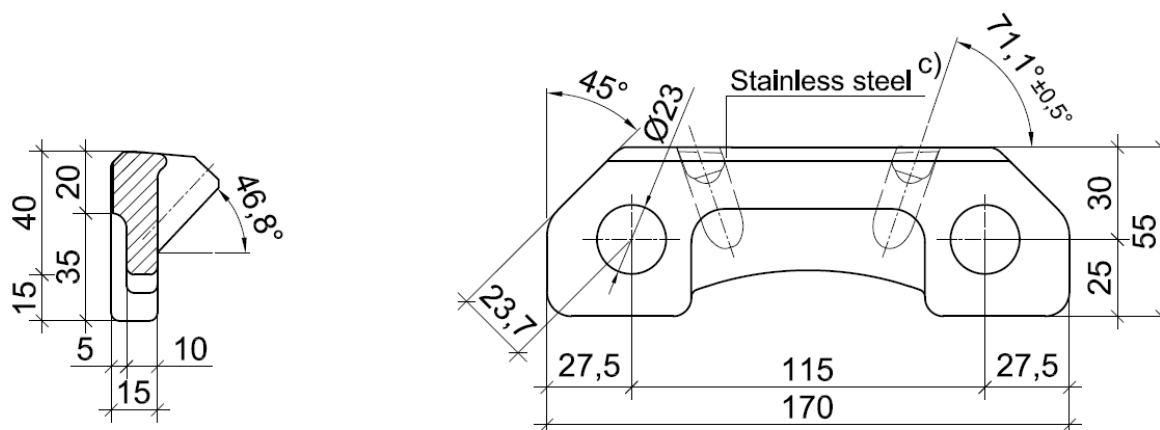

Fig.25: Bearing plate

Table 3: T type SK-MM2 shear bars and anchorage lengths

Type	Shear bar	C20/25		Distribution bar
Load capacity	Quantity x d	$l_{bd1}$	$l_{bd2}$	Quantity x d
	[mm]	[mm]	[mm]	[mm]
T type SK-MM2-VV1	2 x 10	662	463	1 x 8
T type SK-MM2-VV2	2 x 12	794	556	1 x 8

a) b) c) See Section 2.1.2 for material specifications

Schöck Isokorb® T/XT types SK/SQ

Dimensions for T types SK-MM2-VV1 and SK-MM2-VV2

Annex 5  
 Page 3/3

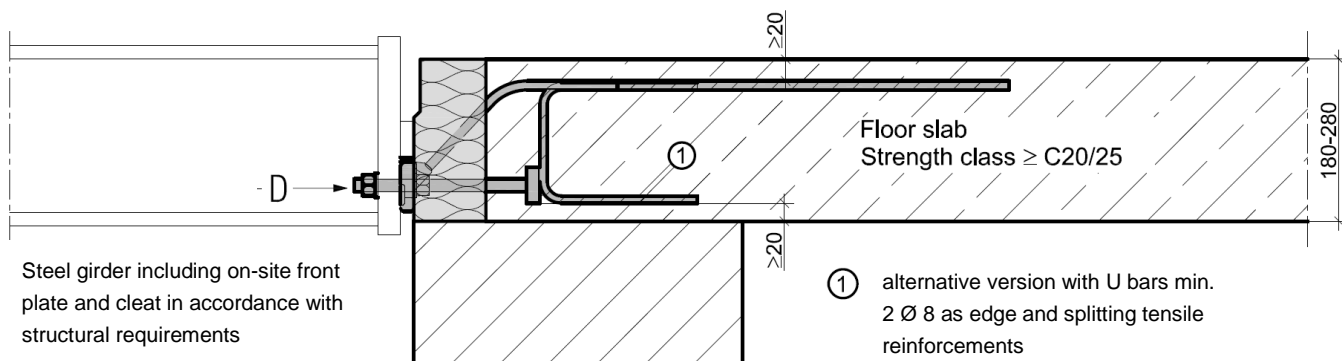

Fig.26: Schöck Isokorb® T types SQ-V1, SQ-V2 and SQ-V3

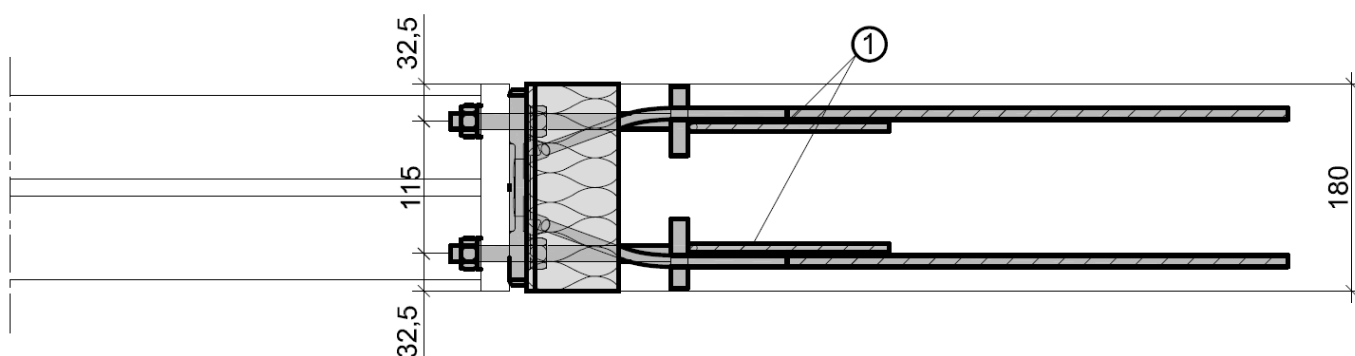

Fig.27: Plan



Abb.28: Compression bearings  $2 \text{ } \varnothing 14$

Schöck Isokorb® T/XT types SK/SQ

Dimensions for T types SQ-V1, SQ-V2 and SQ-V3

Annex 6  
 Page 1/3

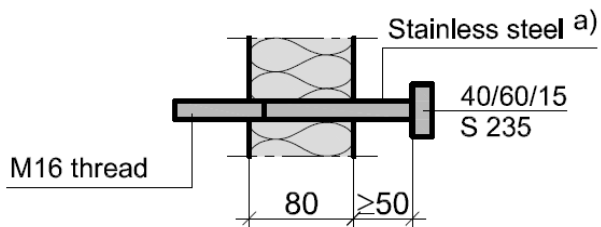

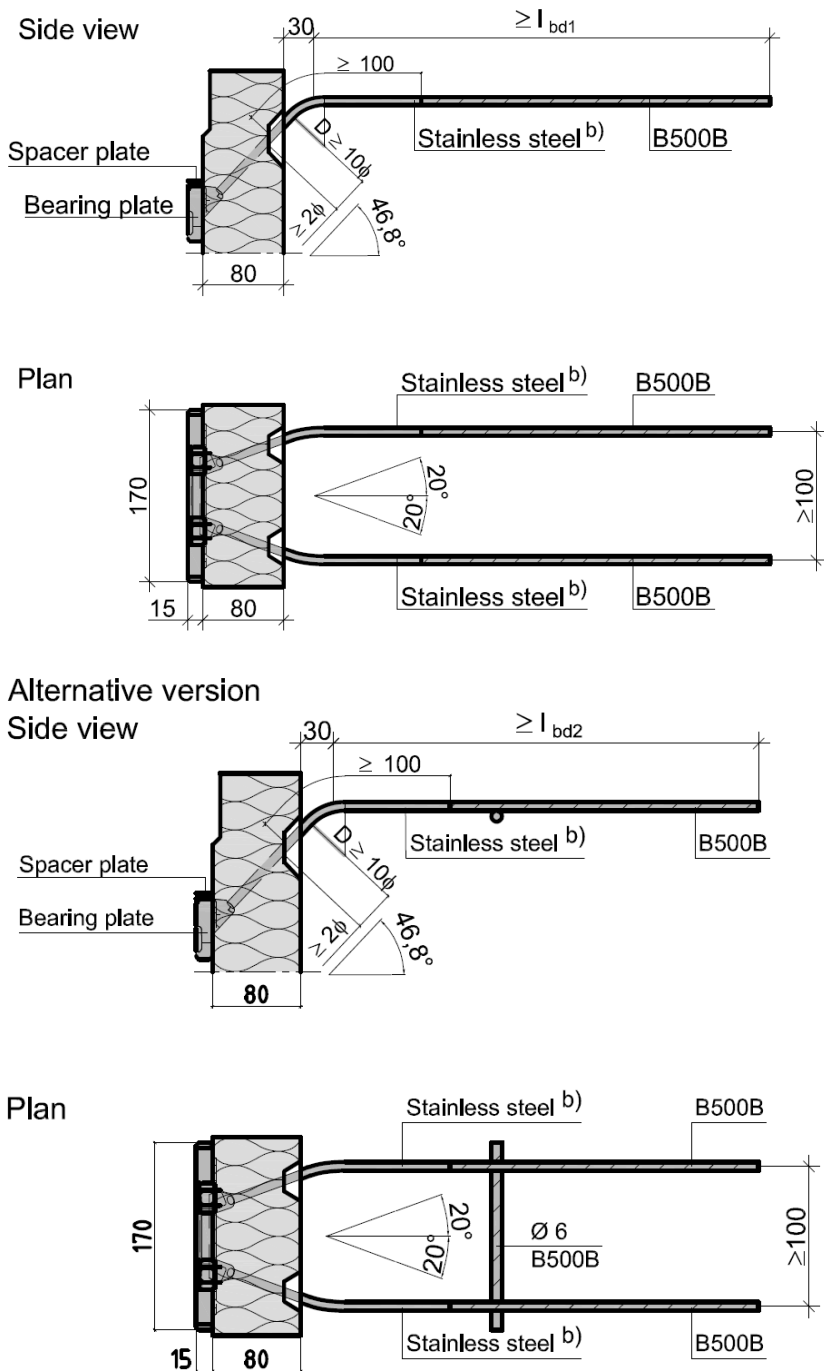

Fig.29a to 29d: Shear bars 2 Ø d incl. bearing plate

Schöck Isokorb® T/XT types SK/SQ

Dimensions for T types SQ-V1, SQ-V2 and SQ-V3

Annex 6  
 Page 2/3

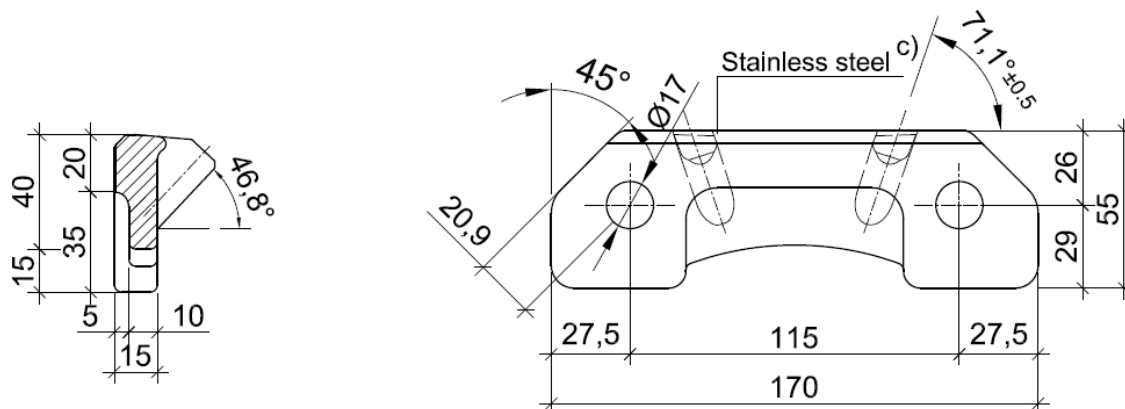

Fig.30: Bearing plate

Table 4: T type SQ shear bars and anchorage lengths

Type	Shear bar	C20/25		Distribution bar
Load capacity	Quantity x d	$l_{bd1}$	$l_{bd2}$	Quantity x d
	[mm]	[mm]	[mm]	[mm]
T type SQ-V1	2 x 8	530	371	1 x 6
T type SQ-V2	2 x 10	662	463	1 x 8
T type SQ-V3	2 x 12	794	556	1 x 8

a) b) c) See Section 2.1.2 for material specifications

Schöck Isokorb® T/XT types SK/SQ

Dimensions for T types SQ-V1, SQ-V2 and SQ-V3

Annex 6  
 Page 3/3

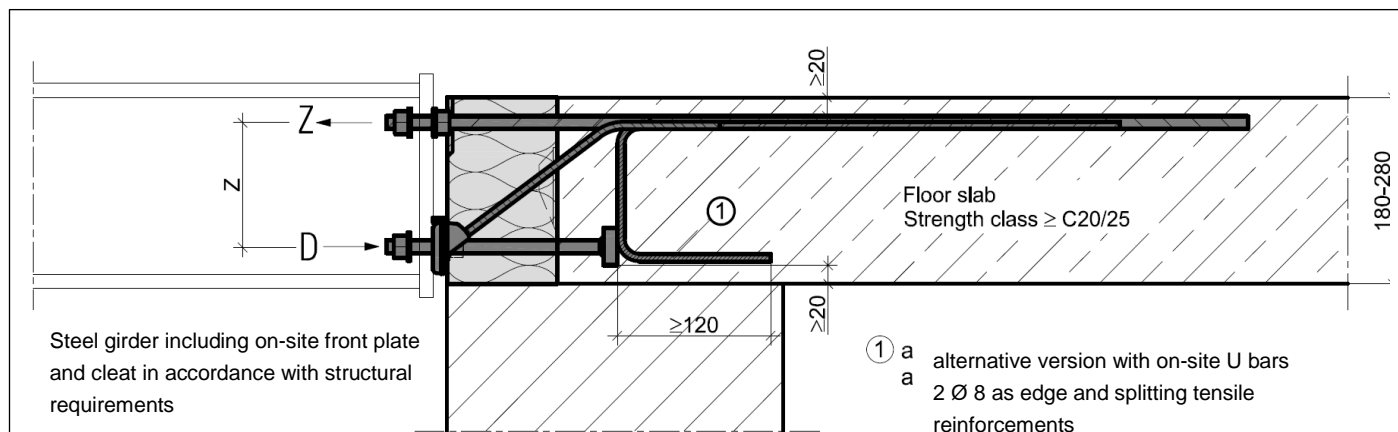

Fig.31: Schöck Isokorb® XT types SK-M1V1 and SK-M1-V2

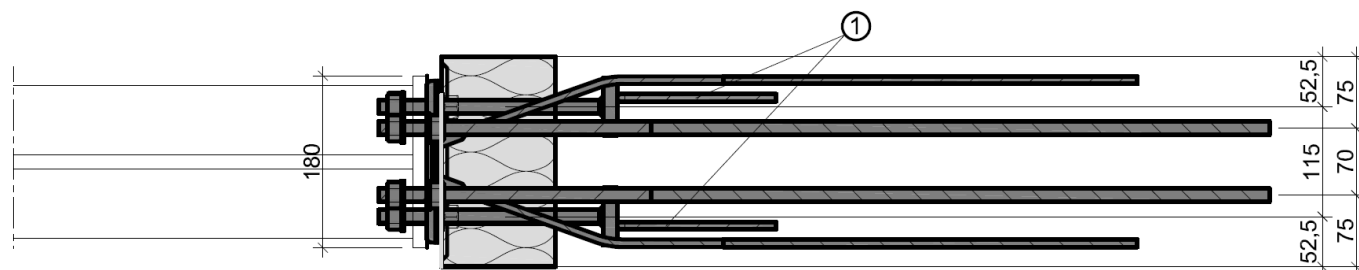

Fig.32: Plan



Fig.33: Tensile bars 2  $\varnothing$  14

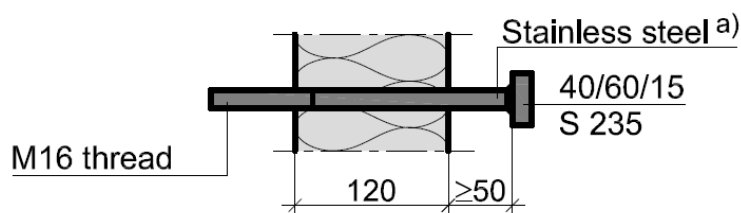

Fig.34: Compression bearings 2  $\varnothing$  14

Schöck Isokorb® T/XT types SK/SQ

Dimensions for XT types SK-M1-V1 and SK-M1-V2

Annex 7  
 Page 1/3

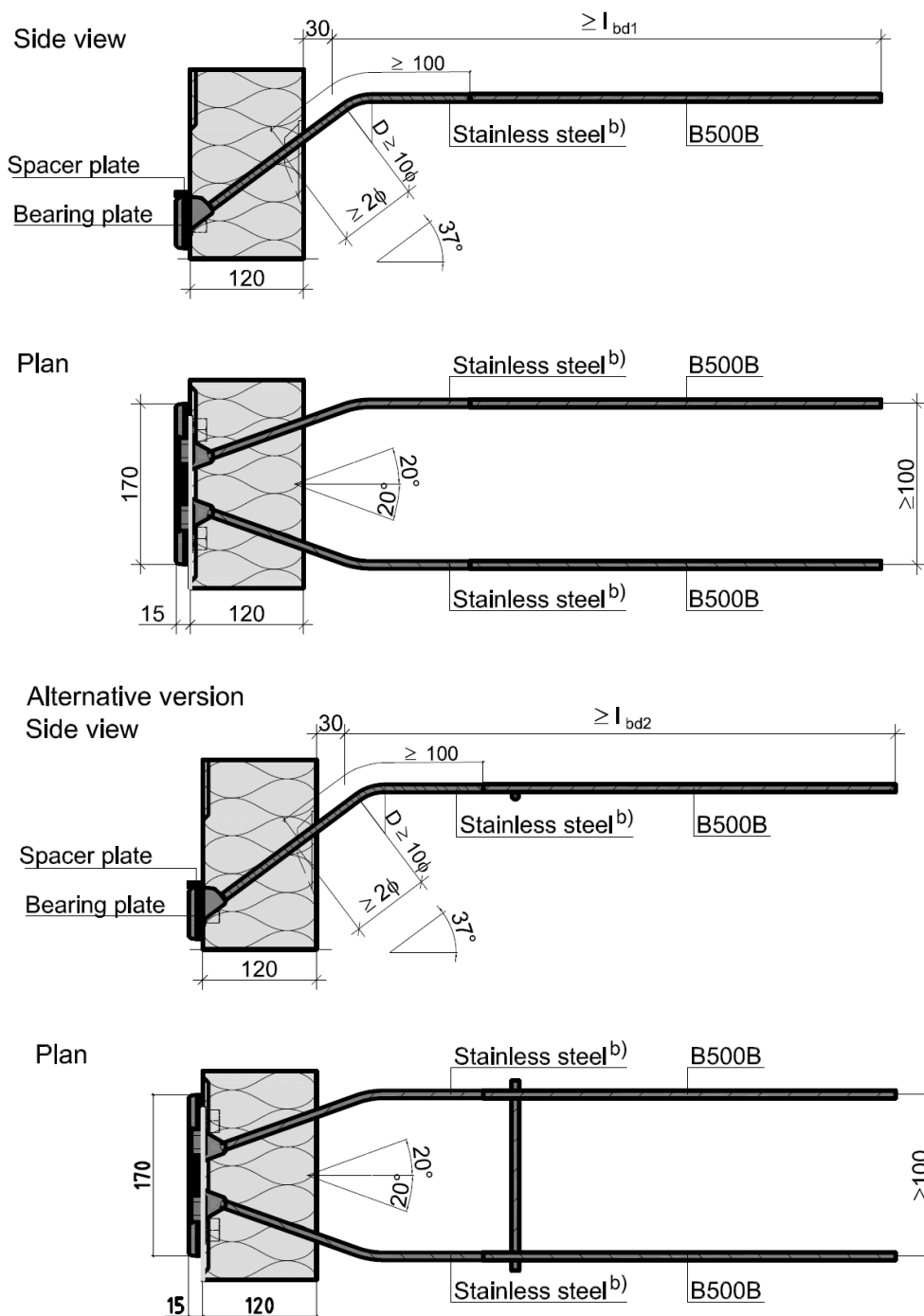

Fig.35a to 35d: Shear bars 2 Ø d incl. bearing plate

Schöck Isokorb® T/XT types SK/SQ

Dimensions for XT types SK-M1-V1 and SK-M1-V2

Annex 7  
 Page 2/3

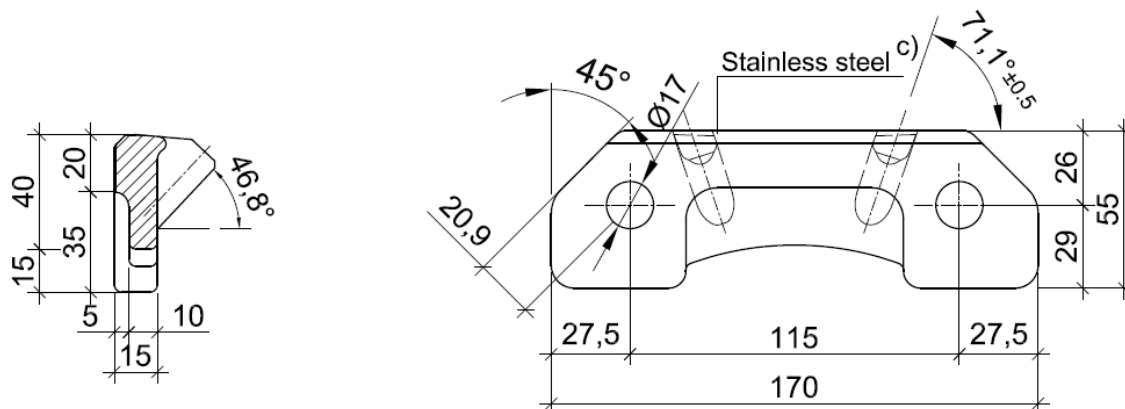

Fig.36: Bearing plate

Table 5: XT type SK-M1 shear bars and anchorage lengths

Type	Shear bar	C20/25		C25/30		Distribution bar
Load capacity	Quantity x d	$l_{bd1}$	$l_{bd2}$	$l_{bd1}$	$l_{bd2}$	Quantity x d
	[mm]	[mm]	[mm]	[mm]	[mm]	[mm]
XT type SK-M1-V1	2 x 8	530	371	451	316	1 x 6
XT type SK-M1-V2	2 x 10	662	463	564	395	1 x 6

a) b) c) See Section 2.1.2 for material specifications

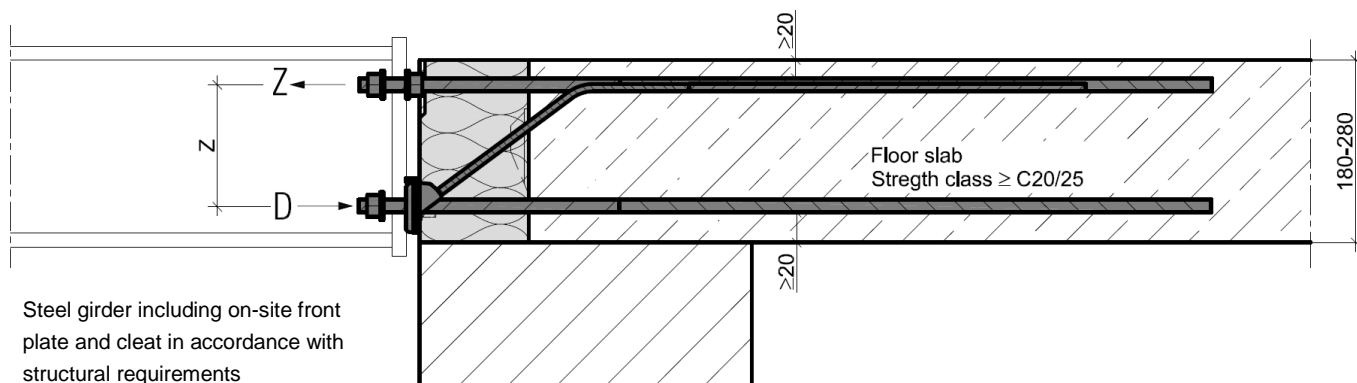

Fig.37: Schöck Isokorb® XT type SK-MM1-VV1

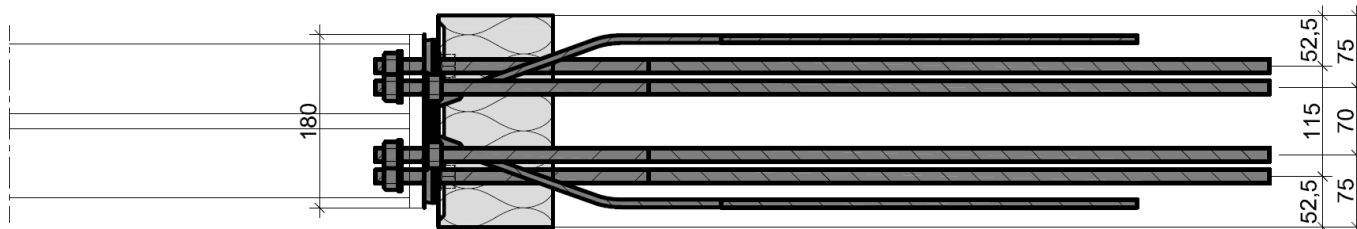

Fig.38: Plan



Fig.39: Tensile and compression bars 2 x 2  $\varnothing$  14

Schöck Isokorb® T/XT types SK/SQ

Dimensions for XT type SK-MM1-VV1

Annex 8  
 Page 1/3

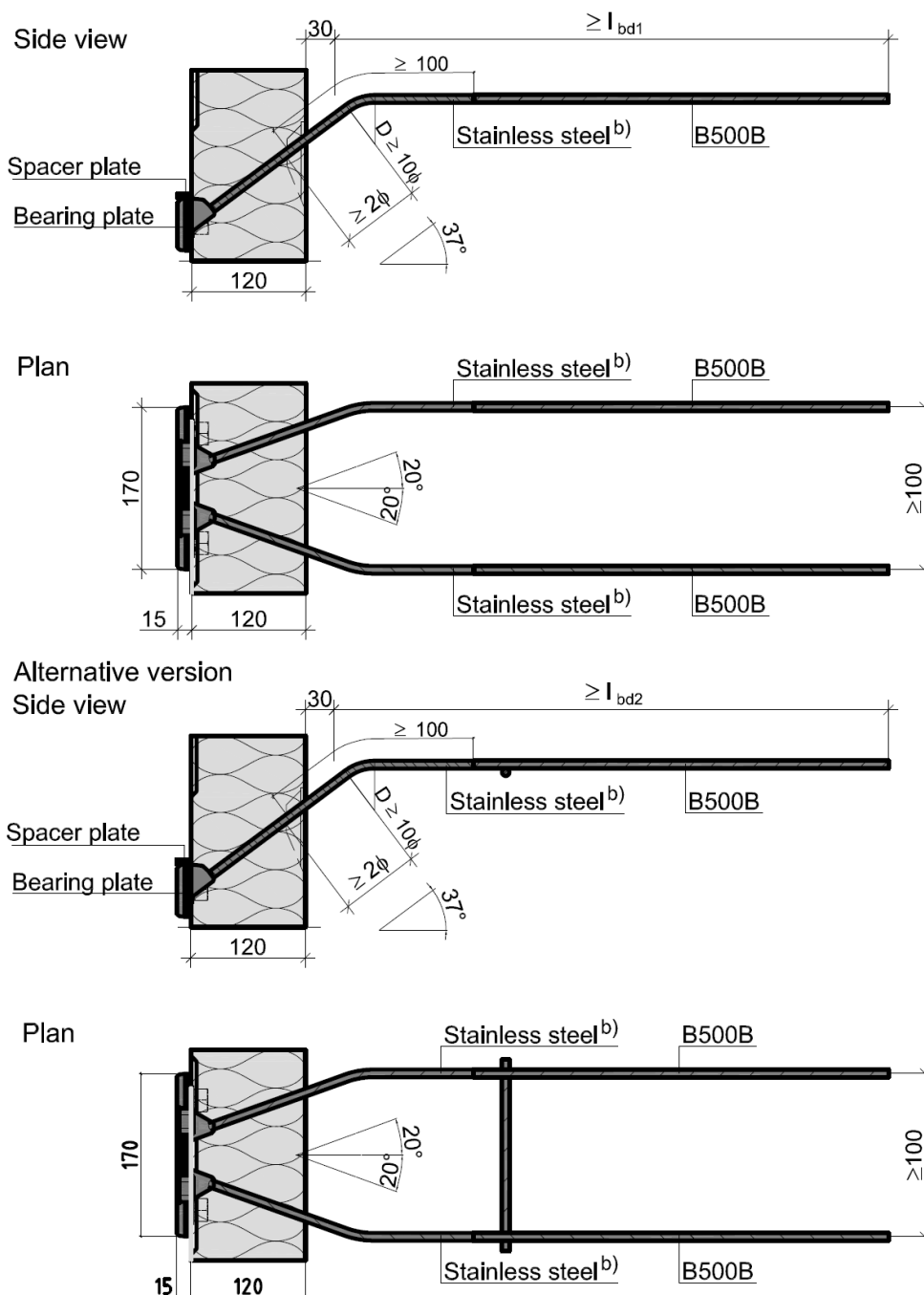

Fig.40a to 40d: Shear bars 2 Ø d incl. bearing plate

Schöck Isokorb® T/XT types SK/SQ

Dimensions for XT type SK-MM1-VV1

Annex 8  
 Page 2/3



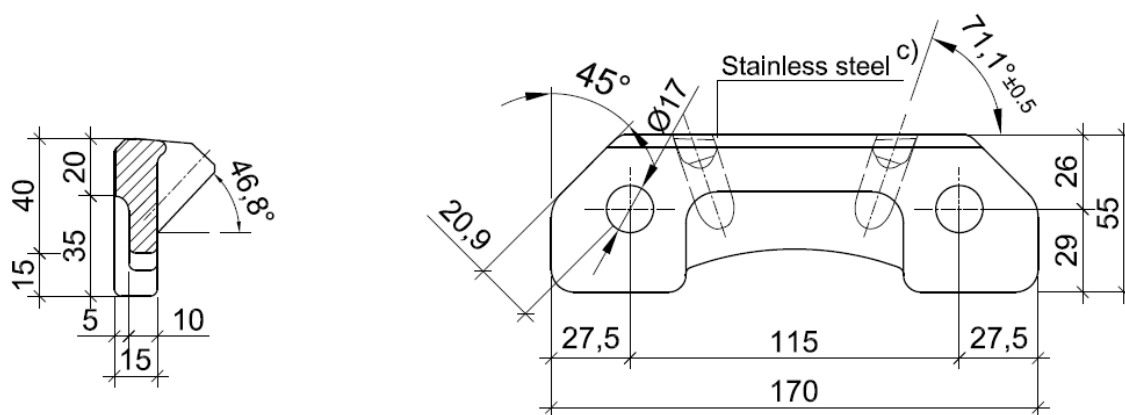

Fig.41: Bearing plate

Table 6: XT type SK-MM1-VV1 shear bars and anchorage lengths

Type	Shear bar	C20/25		C25/30		Distribution bar
Load capacity	Quantity x d	$l_{bd1}$	$l_{bd2}$	$l_{bd1}$	$l_{bd2}$	Quantity x d
	[mm]	[mm]	[mm]	[mm]	[mm]	[mm]
XT type SK-MM1-VV1	2 x 8	530	371	451	316	1 x 6

a) b) c) See Section 2.1.2 for material specifications

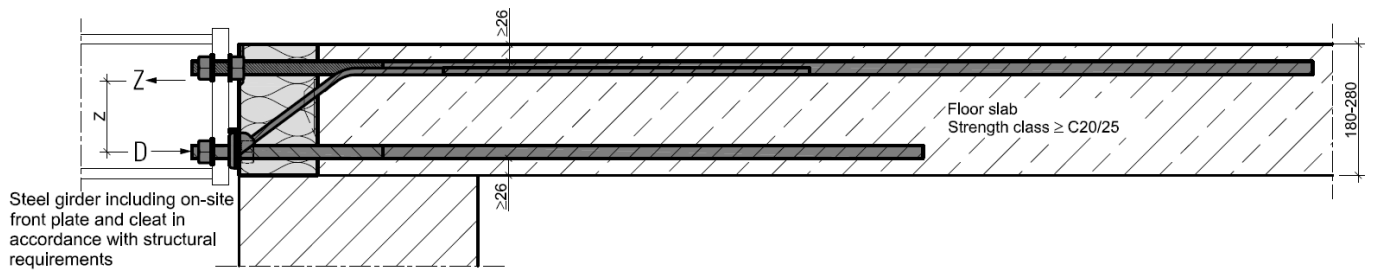

Fig.42: Schöck Isokorb® XT types SK-MM2-VV1 and SK-MM2-VV2

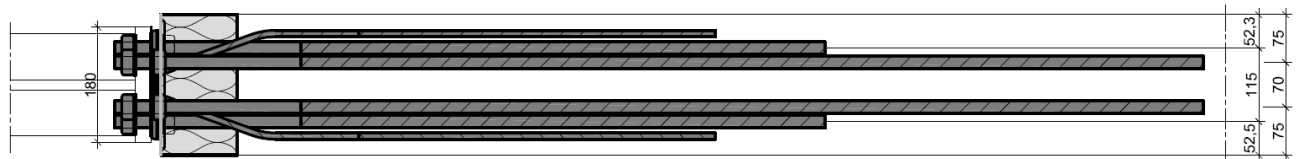

Fig.43: Plan

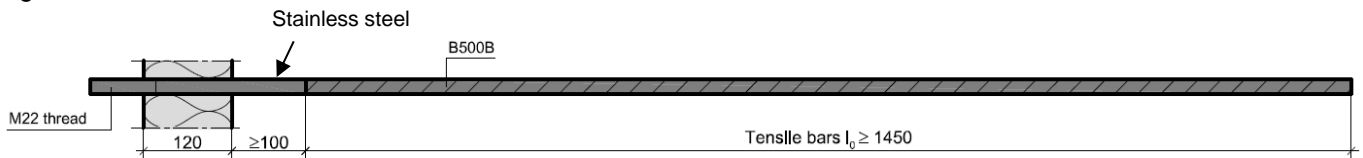

Fig.44: Tensile bars 2 Ø 20

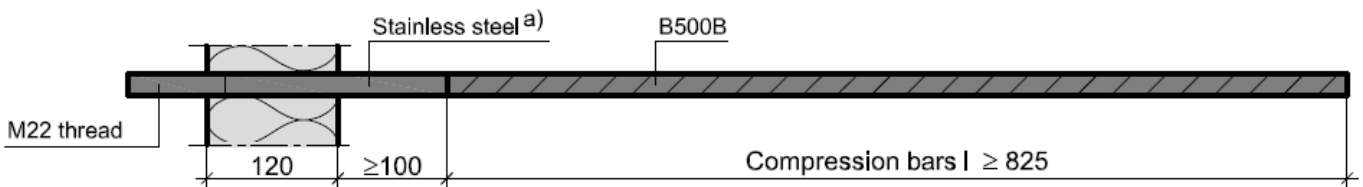

Fig.45: Compression bars 2 Ø 20

Schöck Isokorb® T/XT types SK/SQ

Dimensions for XT types SK-MM2-VV1 and SK-MM2-VV2

Annex 9  
 Page 1/3

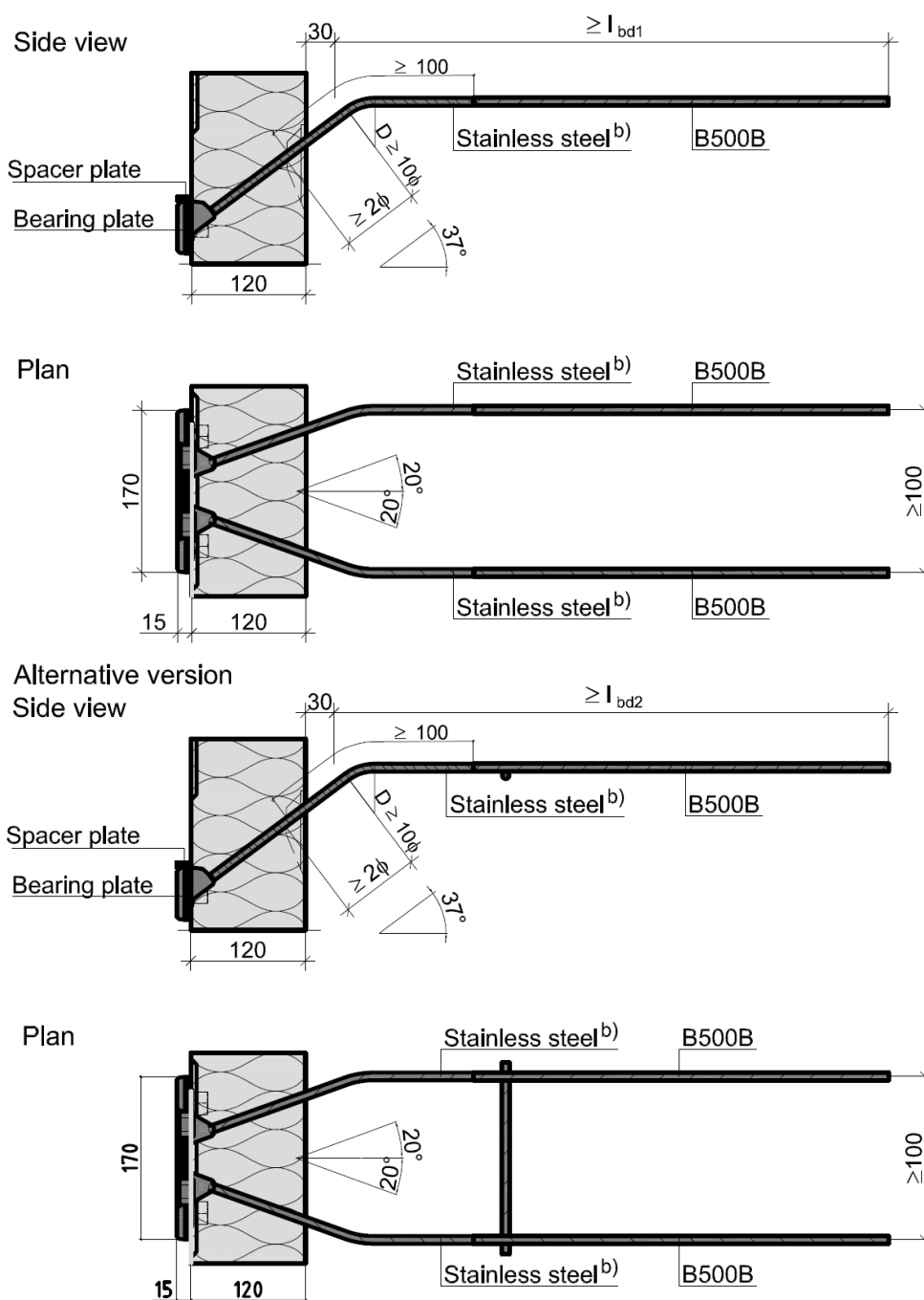

Fig.46a to 46d: Shear bars 2 Ø d incl. bearing plate

Schöck Isokorb® T/XT types SK/SQ

Dimensions for XT types SK-MM2-VV1 and SK-MM2-VV2

Annex 9  
 Page 2/3

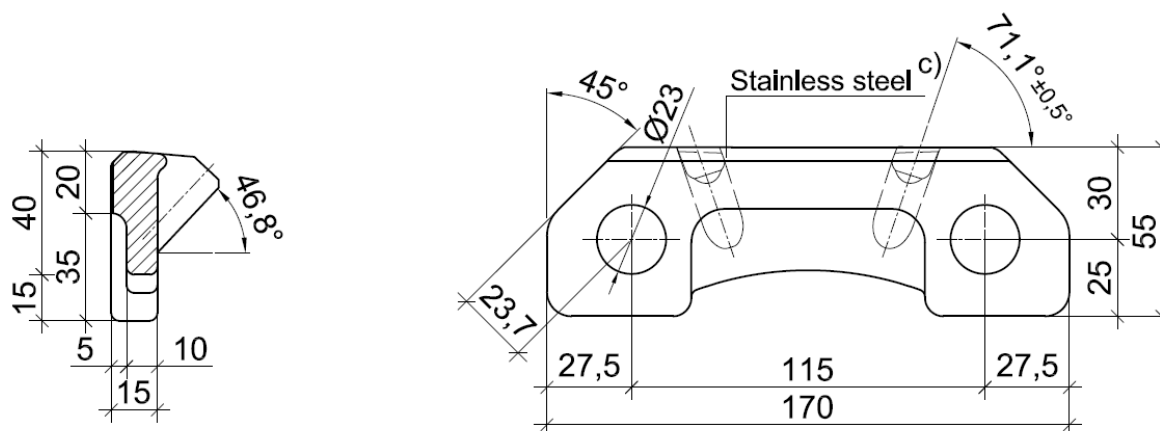

Fig.47: Bearing plate

Table 7: XT type SK-MM2 shear bars and anchorage lengths

Type	Shear bar	C20/25		C25/30		Distribution bar
Load capacity	Quantity x d	$l_{bd1}$	$l_{bd2}$	$l_{bd1}$	$l_{bd2}$	Quantity x d
	[mm]	[mm]	[mm]	[mm]	[mm]	[mm]
XT type SK-MM2-VV1	2 x 10	662	463	564	395	1 x 8
XT type SK-MM2-VV2	2 x 12	794	556	677	474	1 x 8

a) b) c) See Section 2.1.2 for material specifications

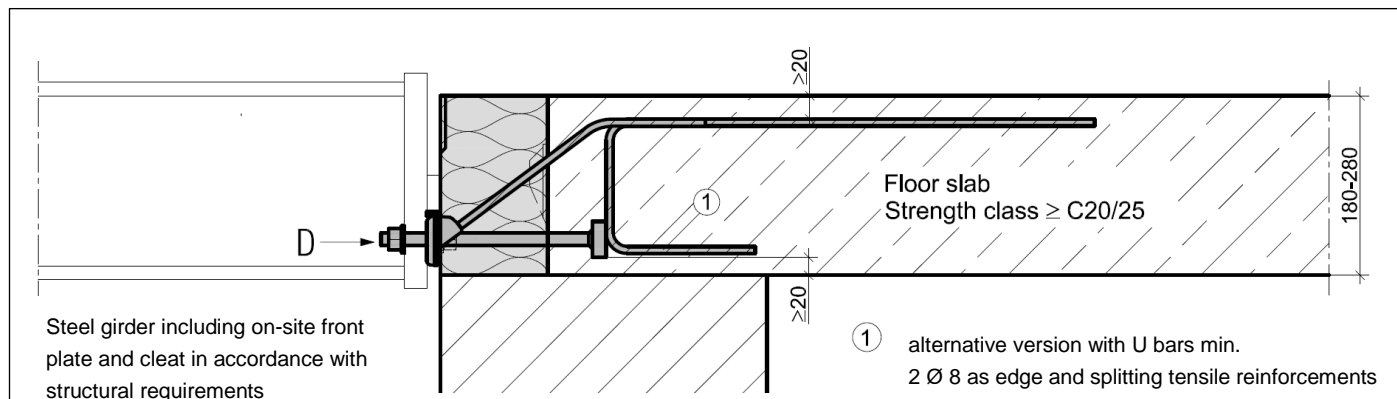

Fig.48: Schöck Isokorb® XT types SQ-V1, SQ-V2 and SQ-V3

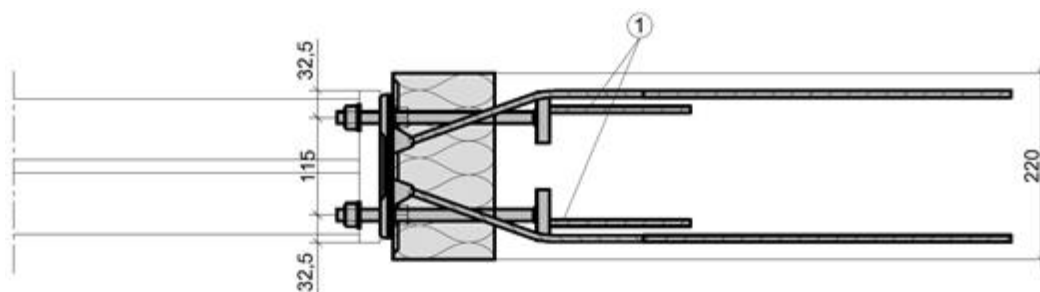

Fig.49: Plan

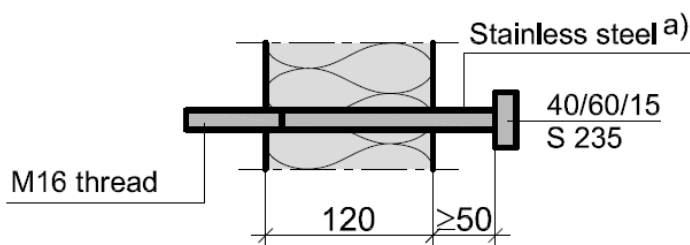

Fig.50: Compression bearings 2  $\varnothing$  14

Schöck Isokorb® T/XT types SK/SQ

Dimensions for XT types SQ-V1, SQ-V2 and SQ-V3

Annex 10  
 Page 1/3

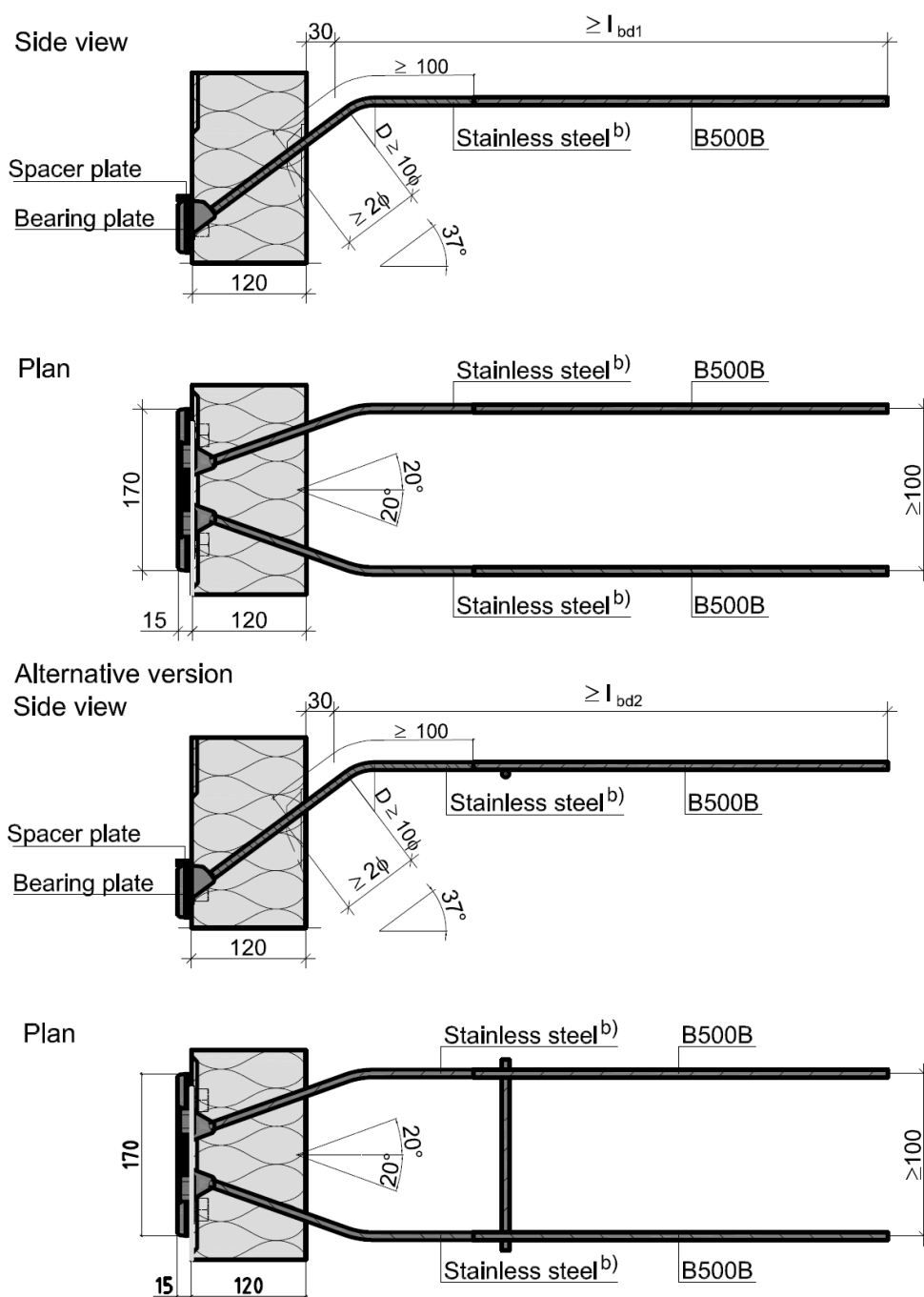

Fig.51a to 51d: Shear bars 2 Ø d incl. bearing plate

Schöck Isokorb® T/XT types SK/SQ

Dimensions for XT types SQ-V1, SQ-V2 and SQ-V3

Annex 10  
 Page 2/3

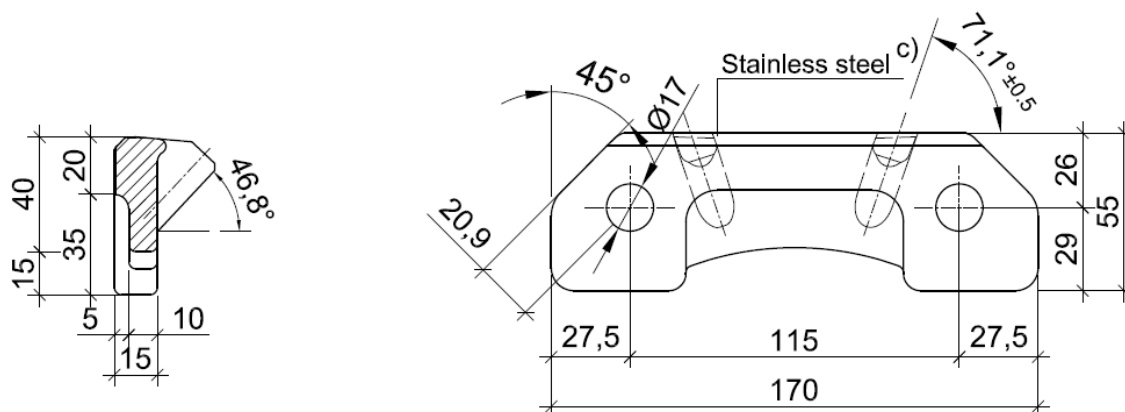

Fig.52: Bearing plate

Table 8: XT type SQ shear bars and anchorage lengths

Type	Shear bar	C20/25		C25/30		Distribution bar
		Quantity x d	$l_{bd1}$	$l_{bd2}$	$l_{bd1}$	
Load capacity	[mm]	[mm]	[mm]	[mm]	[mm]	[mm]
XT type SQ-V1	2 x 8	530	371	451	316	1 x 6
XT type SQ-V2	2 x 10	662	463	564	395	1 x 8
XT type SQ-V3	2 x 12	794	556	677	474	1 x 8

a) b) c) See Section 2.1.2 for material specifications

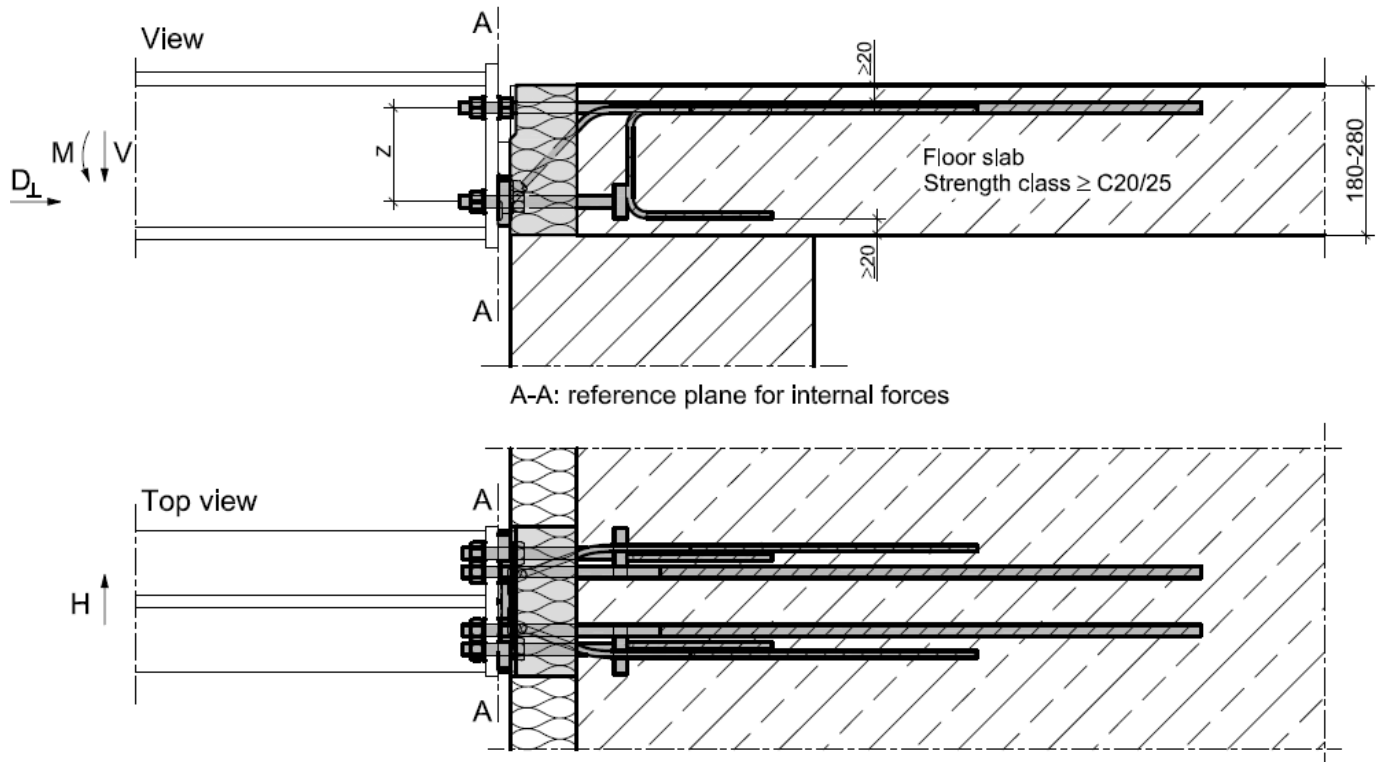

Fig.53 and 54: Schöck Isokorb® T types SK-M1-V1 and SK-M1-V2, definition of internal forces

Schöck Isokorb® T/XT types SK/SQ

Design internal forces for T types SK-M1-V1 and SK-M1-V2

Annex 11  
 Page 1/2



Table 9: Design internal forces for T types SK-M1-V1 and SK-M1-V2

Load case: positive shear forces		T type SK-M1-V1			T type SK-M1-V2		
C20/25		M <sub>Rd</sub> [kNm] for			M <sub>Rd</sub> [kNm] for		
h	z	H <sub>Rd</sub> [kN]	selected V <sub>Ed</sub> [kN]	V <sub>Rd</sub> [kN]	H <sub>Rd</sub> [kN]	selected V <sub>Ed</sub> [kN]	V <sub>Rd</sub> [kN]
[mm]	[mm]		≤ 10,0	30,9		≤ 10,0	30,9
180	113	± 2,5	10,98	8,76	± 4,0	10,79	6,91
190	123		11,95	9,53		11,75	7,52
200	133		12,92	10,31		12,70	8,13
210	143		13,89	11,08		13,66	8,74
220	153		14,86	11,86		14,61	9,35
230	163		15,83	12,63		15,57	9,96
240	173		16,80	13,41		16,52	10,57
250	183		17,77	14,18		17,48	11,19
260	193		18,75	14,96		18,44	11,80
270	203		19,72	15,73		19,39	12,41
280	213		20,69	16,51		20,34	13,02

M<sub>Rd</sub> may be interpolated for selected V<sub>Ed</sub> ≤ V<sub>Ed</sub> ≤ V<sub>Rd</sub>

1) For horizontal forces H<sub>Ed</sub> > 0,342 x min. V<sub>Ed</sub> the transmission of the loads between the on-site front plate and the compression bars shall be ensured. For this, round holes can be arranged in the front plate or the screws can be appropriately preloaded.

Table 10: Design internal forces D<sub>⊥</sub> for T type SK-M1 (max. horizontal force perpendicular to insulation joint)

h	Load case: positive shear forces
	D <sub>Rd ⊥</sub>
[mm]	[kN]
180-280	106,5

For horizontally acting forces D<sub>Ed ⊥</sub> perpendicular to the insulation joint, the bending moments M<sub>Rd</sub> shall be determined in accordance with Annex 16.

Schöck Isokorb® T/XT types SK/SQ

Design internal forces for T types SK-M1-V1 and SK-M1-V2

Annex 11  
 Page 2/2

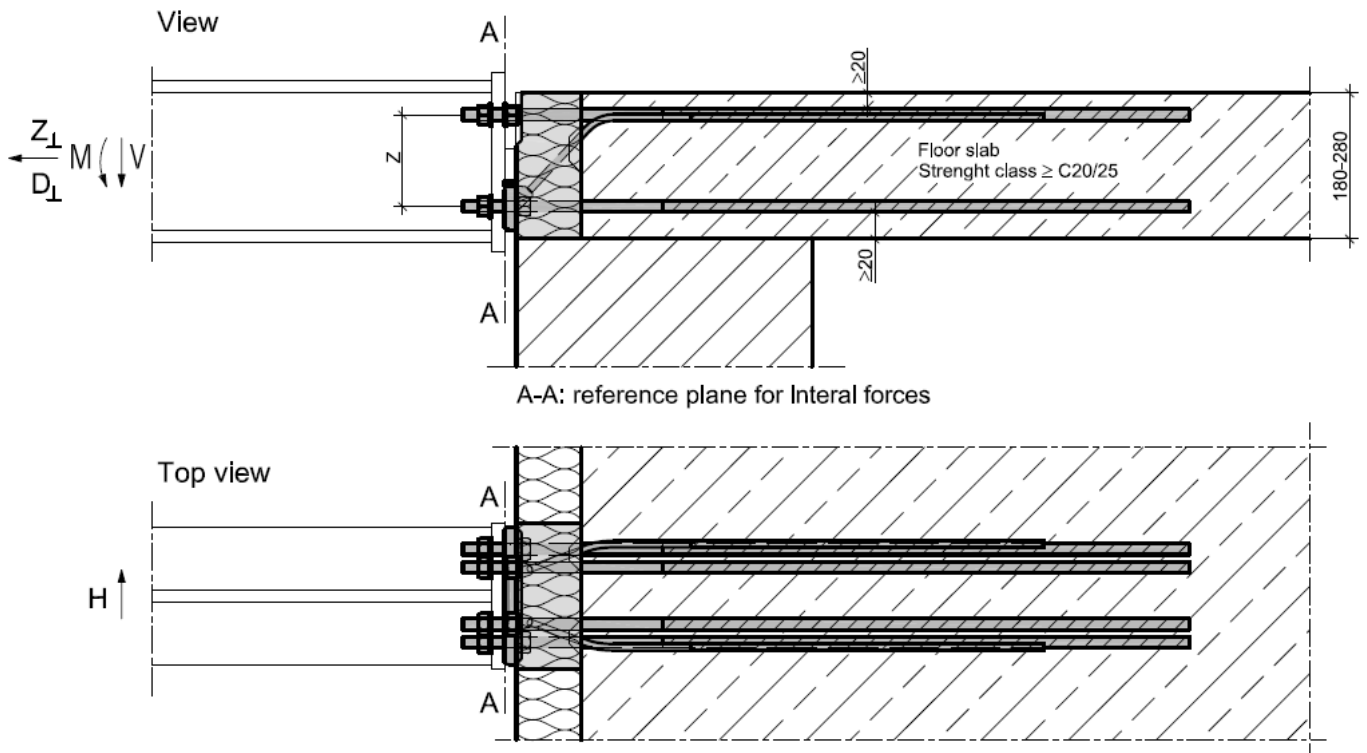

Fig.55 and 56: Schöck Isokorb® XT type SK-MM1-VV1, definition of internal forces

Table 11: Design internal forces for T type SK-MM1-VV1

T type SK-MM1-VV1			Load case: negative (uplifting) shear forces	Load case: positive shear forces	
M <sub>Rd</sub> [kNm] for			C20/25	C20/25	
h	z	H <sub>Rd</sub> [kN]	V <sub>Rd</sub> [kN]	selected V <sub>Ed</sub> [kN]	V <sub>Rd</sub> [kN]
[mm]	[mm]		-12,0	≤ 11,1	30,9
180	113	± 2,5	-9,75	11,02	8,93
190	123		-10,61	12,00	9,72
200	133		-11,47	12,97	10,51
210	143		-12,34	13,95	11,30
220	153		-13,20	14,92	12,09
230	163		-14,06	15,90	12,88
240	173		-14,92	16,88	13,67
250	183		-15,79	17,85	14,46
260	193		-16,65	18,83	15,25
270	203		-17,51	19,80	16,04
280	213		-18,38	20,78	16,83

M<sub>Rd</sub> may be interpolated for selected  $V_{Ed} \leq V_{Ed} \leq V_{Rd}$

1) For negative (uplifting) shear forces and horizontal forces of  $H_{Ed} > 0,342 \times \min. V_{Ed}$  the transmission of the loads between the on-site front plate and the compression bars shall be ensured. For this, round holes can be arranged in the front plate or the screws can be appropriately preloaded.

Table 12: Design internal forces Z<sub>⊥</sub> and D<sub>⊥</sub> for T type SK-MM1-VV1 (max. horizontal force perpendicular to insulation joint)

h	Load case: negative (uplifting) shear forces	Load case: positive shear forces
	Z <sub>Rd1 ⊥</sub> or D <sub>Rd,1 ⊥</sub>	Z <sub>Rd2 ⊥</sub> or D <sub>Rd,2 ⊥</sub>
[mm]	[kN]	[kN]
180-280	±128,7	±108,1

For horizontally acting forces D<sub>Ed ⊥</sub> perpendicular to the insulation joint, the bending moments M<sub>Rd</sub> shall be determined in accordance with Annex 16.

Schöck Isokorb® T/XT types SK/SQ

Design internal forces for T type SK-MM1-VV1

Annex 12  
 Page 2/2

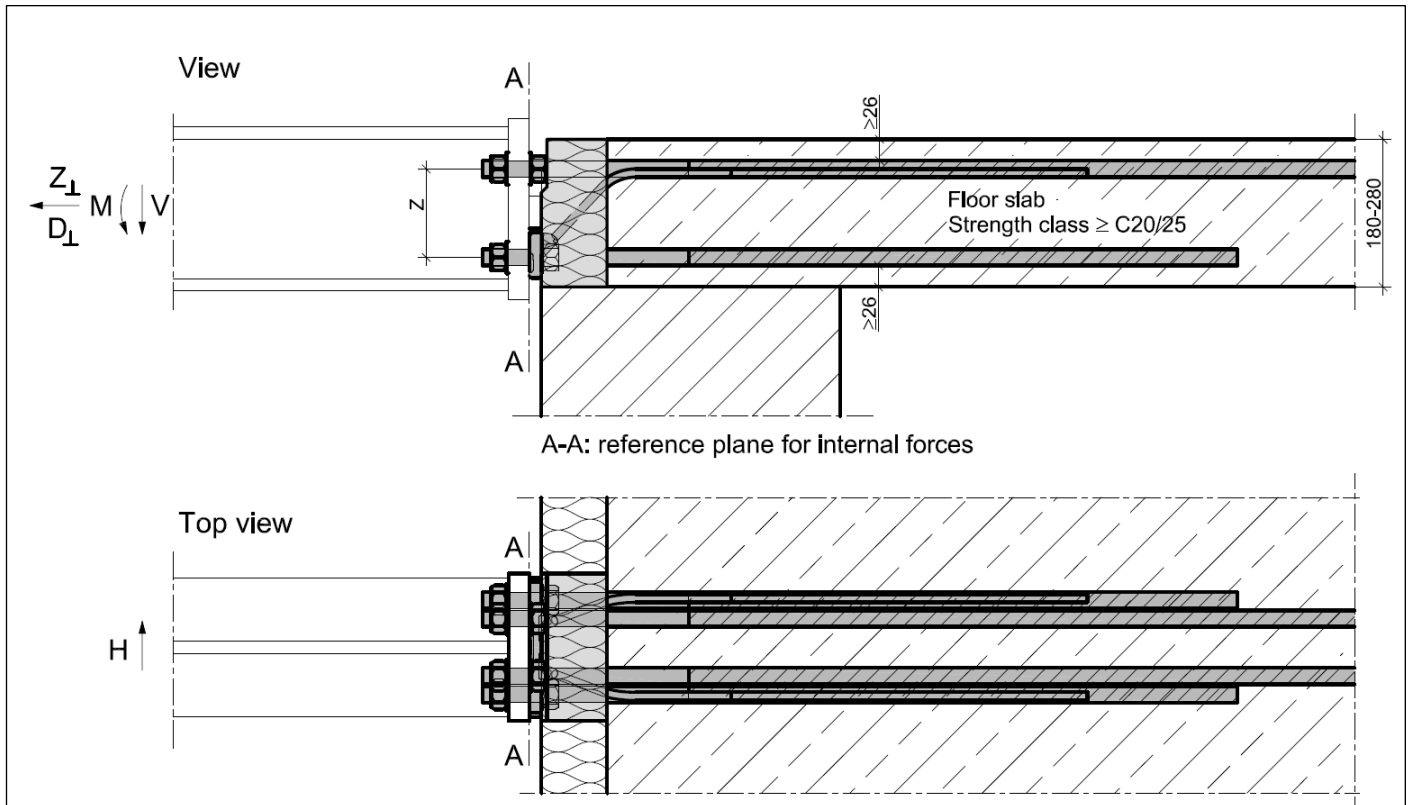

Fig.57 and 58: Schöck Isokorb® T type SK-MM2-VV1, definition of internal forces

Schöck Isokorb® T/XT types SK/SQ

Design internal forces for T type SK-MM2-VV1

Annex 13  
 Page 1/2

Table 13: Design internal forces for T type SK-MM2-VV1

T type SK-MM2-VV1			Load case: negative (uplifting) shear forces	Load case: positive shear forces	
M <sub>Rd</sub> [kNm] for			C20/25	C20/25	
h	z	H <sub>Rd</sub> [kN]	V <sub>Rd</sub> [kN]	selected V <sub>Ed</sub> [kN]	V <sub>Rd</sub> [kN]
[mm]	[mm]		-12,0	≤ 25,0	48,3
180	108	± 4,0	-11,66	22,63	20,27
190	118		-12,74	24,73	22,15
200	128		-13,82	26,82	24,03
210	138		-14,90	28,92	25,91
220	148		-15,98	31,01	27,78
230	158		-17,06	33,11	29,66
240	168		-18,14	35,20	31,54
250	178		-19,21	37,30	33,41
260	188		-20,29	39,39	35,29
270	198		-21,37	41,49	37,17
280	208		-22,45	43,59	39,05

M<sub>Rd</sub> may be interpolated for selected V<sub>Ed</sub> ≤ V<sub>Ed</sub> ≤ V<sub>Rd</sub>

1) For negative shear forces and horizontal forces H<sub>Ed</sub> > 0,342 x min. V<sub>Ed</sub> the transmission of the loads between the on-site front plate and the compression bars shall be ensured. For this, round holes can be arranged in the front plate or the screws can be appropriately preloaded.

Table 14: Design internal forces Z<sub>⊥</sub> and D<sub>⊥</sub> for T type SK-MM2-VV1  
 (max. horizontal force perpendicular to insulation joint)

h	Load case: negative (uplifting) shear forces	Load case: positive shear forces
	Z <sub>Rd1 ⊥</sub> or D <sub>Rd,1 ⊥</sub>	Z <sub>Rd2 ⊥</sub> or D <sub>Rd,2 ⊥</sub>
[mm]	[kN]	[kN]
180- 280	±233,1	±233,1

For horizontally acting forces D<sub>Ed ⊥</sub> perpendicular to the insulation joint, the bending moments M<sub>Rd</sub> shall be determined in accordance with Annex 16.

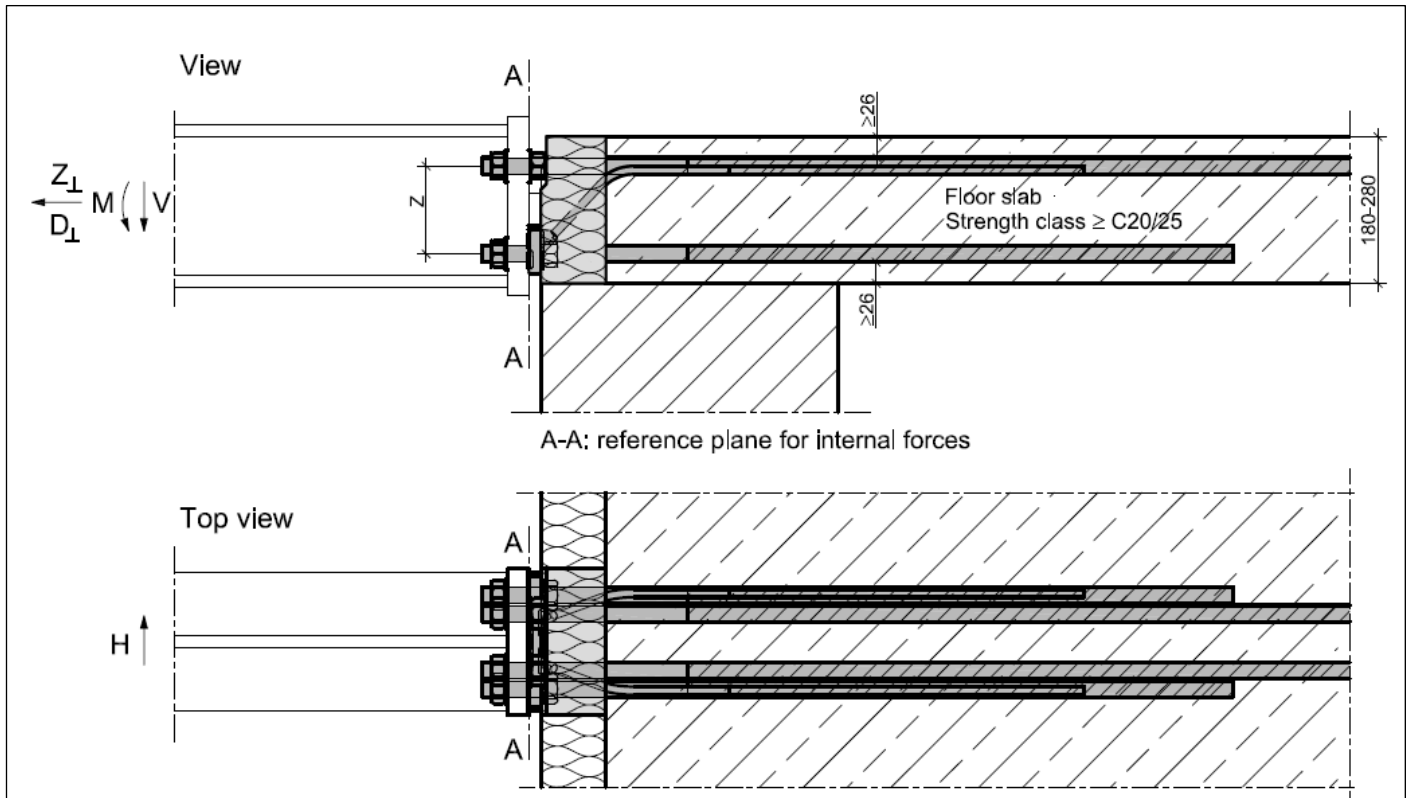

Fig.59 and 60: Schöck Isokorb® T type SK-MM2-VV2, definition of internal forces

Schöck Isokorb® T/XT types SK/SQ

Design internal forces for T type SK-MM2-VV2

Annex 14  
 Page 1/2

Table 15: Design internal forces T type SK-MM2-VV2

T type SK-MM2-VV2			Load case: negative (uplifting) shear forces	Load case: positive shear forces	
M <sub>Rd</sub> [kNm] for			C20/25	C20/25	
h	z	H <sub>Rd</sub> [kN]	V <sub>Rd</sub> [kN]	selected V <sub>Ed</sub> [kN]	V <sub>Rd</sub> [kN]
[mm]	[mm]		-12,0	≤ 25,0	69,5
180	108	± 6,5	-10,95	22,63	18,12
190	118		-11,96	24,73	19,80
200	128		-12,97	26,82	21,48
210	138		-13,99	28,92	23,16
220	148		-15,00	31,01	24,83
230	158		-16,02	33,11	26,51
240	168		-17,03	35,20	28,19
250	178		-18,04	37,30	29,87
260	188		-19,06	39,39	31,55
270	198		-20,07	41,49	33,22
280	208		-21,08	43,59	34,90

M<sub>Rd</sub> may be interpolated for selected V<sub>Ed</sub> ≤ V<sub>Ed</sub> ≤ V<sub>Rd</sub>

1) For negative shear forces and horizontal forces of H<sub>Ed</sub> > 0,342 x min. V<sub>Ed</sub> the transmission of the loads between the on-site front plate and the compression bars shall be ensured. For this, round holes can be arranged in the front plate or the screws can be appropriately preloaded.

Tab. 16: Design internal forces Z<sub>⊥</sub> and D<sub>⊥</sub> for T type SK-MM2-VV2  
 (max. horizontal force perpendicular to insulation joint)

h	Load case: negative (uplifting) shear forces	Load case: positive shear forces
	Z <sub>Rd1 ⊥</sub> or D <sub>Rd,1 ⊥</sub>	Z <sub>Rd2 ⊥</sub> or D <sub>Rd,2 ⊥</sub>
[mm]	[kN]	[kN]
180-280	±233,1	±233,1

For horizontally acting forces D<sub>Ed ⊥</sub> perpendicular to the insulation joint, the bending moments M<sub>Rd</sub> shall be determined in accordance with Annex 16.

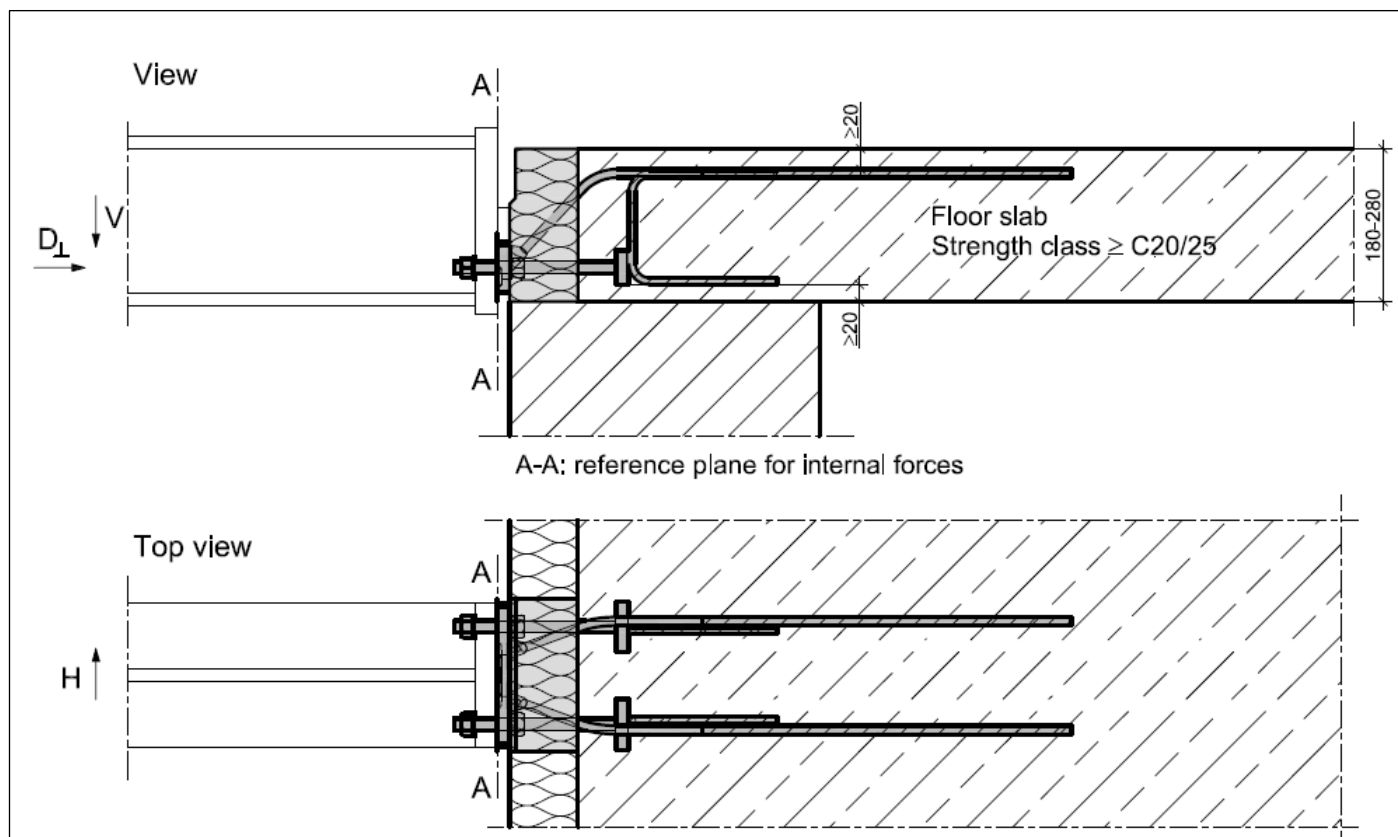

Fig.61 and 62: Schöck Isokorb® T types SQ-V1, SQ-V2 and SQ-V3, definition of internal forces



Table 17: Design internal forces for T types SQ-V1, SQ-V2 and SQ-V3

Load case: positive shear forces	T type SQ-V1			T type SQ-V2			T type SQ-V3		
C20/25									
h [mm]	H <sub>Rd</sub> [kN]	V <sub>Rd</sub> [kN]	D <sub>Rd ⊥</sub> [kN]	H <sub>Rd</sub> [kN]	V <sub>Rd</sub> [kN]	D <sub>Rd ⊥</sub> [kN]	H <sub>Rd</sub> [kN]	V <sub>Rd</sub> [kN]	D <sub>Rd ⊥</sub> [kN]
180									
190									
200									
210									
220									
230	± 4,0	30,9	106,5	± 4,0	48,3	106,5	± 6,5	69,58	106,50
240									
250									
260									
270									
280									

1) For horizontal forces of  $H_{Ed} > 0,342 \times \min. V_{Ed}$  the transmission of the loads between the on-site front plate and the compression bars shall be ensured. For this, round holes can be arranged in the front plate or the screws can be appropriately preloaded.

2) The horizontally acting forces  $D_{ED \perp}$  perpendicular to the insulation joint are as follows:

For the compression forces  $D_{ED \perp}$ :  $D_{ED \perp} \leq D_{RD \perp} - \cos 20^\circ \cdot |V_{Ed}| - \cos 20^\circ / \sin 20^\circ \cdot |H_{Ed}|$

For the tensile forces  $Z_{ED \perp}$ :  $Z_{ED \perp} \leq \cos 20^\circ \times \min |V_{Ed}| / 1,1$

Schöck Isokorb® T/XT types SK/SQ

Design internal forces for T types SQ-V1, SQ-V2 and SQ-V3

Annex 15  
 Page 2/2

Table 18: Moments  $M_{Rd \perp}$  for horizontal forces ( $D_{Ed \perp}$  and  $Z_{Ed \perp}$ ) perpendicular to the insulation joint for positive shear forces

Isokorb type	$M_{Rd \perp}$ for vertical compression [kNm]	$M_{Rd \perp}$ for vertical tension [kNm]
T type SK-M1-V1 T type SK-M1-V2	$M_{Rd \perp} = \min. \begin{cases} 97,5 \times z/1000 \\ (106,5 - D_{Ed \perp} \downarrow /2 - \cos 20^\circ \times \text{selected } V_{Ed}) \times z/1000 \end{cases}$	
T type SK-MM1-VV1	$M_{Rd \perp} = \min. \begin{cases} 97,5 \times z/1000 \\ (108,1 - D_{Ed \perp} \downarrow /2 - \cos 20^\circ \times \text{selected } V_{Ed}) \times z/1000 \end{cases}$	$M_{Rd \perp} = \min. \begin{cases} (97,5 - Z_{Ed \perp} \downarrow /2) \times z/1000 \\ (108,1 - D_{Ed \perp} \downarrow /2 - \cos 20^\circ \times \text{selected } V_{Ed}) \times z/1000 \end{cases}$
T type SK-MM2-VV1 T type SK-MM2-VV1	$M_{Rd \perp} = \min. \begin{cases} 210,2 \times z/1000 \\ (233,1 - D_{Ed \perp} \downarrow /2 - \cos 20^\circ \times \text{selected } V_{Ed}) \times z/1000 \end{cases}$	$M_{Rd \perp} = \min. \begin{cases} (210,2 - Z_{Ed \perp} \downarrow /2) \times z/1000 \\ (233,1 - \cos 20^\circ \times \text{selected } V_{Ed}) \times z/1000 \end{cases}$

Tab. 19: Moments  $M_{Rd \perp}$  for horizontal forces ( $D_{Ed \perp}$  and  $Z_{Ed \perp}$ ) perpendicular to the insulation joint for negative shear forces (load case: uplift)

Isokorb type	$M_{Rd \perp}$ for vertical compression [kNm]	$M_{Rd \perp}$ for vertical tension [kNm]
T type SK-MM1-VV1	$M_{Rd \perp} = \min. \begin{cases} -1 \times (105,0 - D_{Ed \perp} \downarrow /2) \times z/1000 \\ -1 \times (97,5 - \cos 20^\circ \times \text{selected } IV_{Ed}) \times z/1000 \end{cases}$	$M_{Rd \perp} = \min. \begin{cases} -1 \times 105,0 \times z/1000 \\ -1 \times (97,5 - Z_{Ed \perp} \downarrow /2 - \cos 20^\circ \times \text{selected } IV_{Ed}) \times z/1000 \end{cases}$
T type SK-MM2-VV1 T type SK-MM2-VV2	$M_{Rd \perp} = \min. \begin{cases} -1 \times (228,1 - D_{Ed \perp} \downarrow /2) \times z/1000 \\ -1 \times (119,2 - \cos 20^\circ \times \text{selected } IV_{Ed}) \times z/1000 \end{cases}$	$M_{Rd \perp} = \min. \begin{cases} -1 \times 228,1 \times z/1000 \\ -1 \times (119,2 - Z_{Ed \perp} \downarrow /2 - \cos 20^\circ \times \text{selected } IV_{Ed}) \times z/1000 \end{cases}$

Schöck Isokorb® T/XT types SK/SQ

Moments for horizontal loads perpendicular to joint T

Annex 16

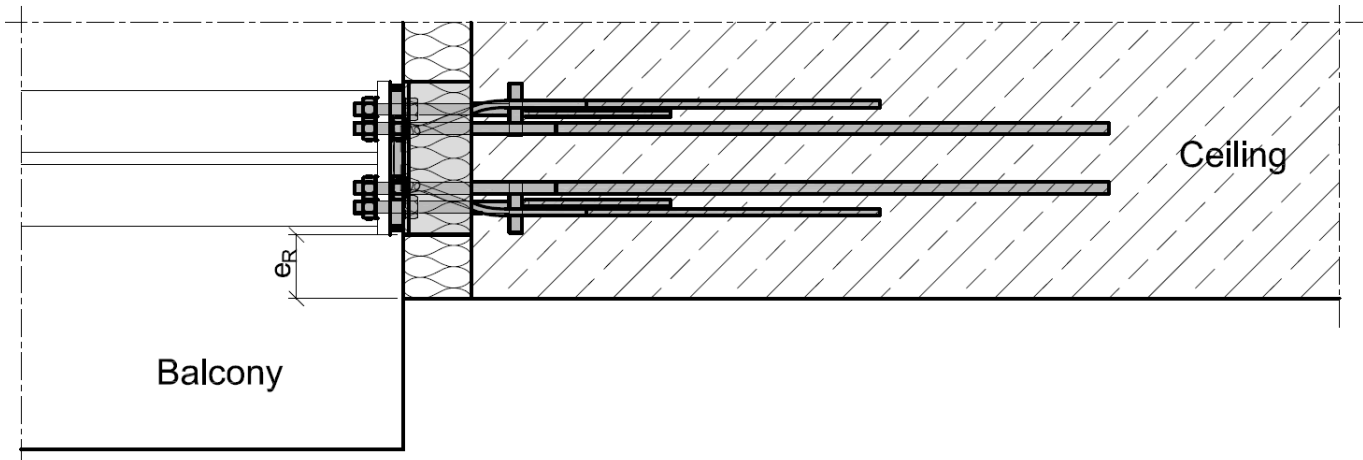

Fig.63 Near-edge installation

Table 20: T types SK and SQ edge distances  $e_R$  with classification as 'near-edge'

'Isokorb' height	Near-edge from $e_R$ [mm]			
	180/190	200/210	220/230	240/280
T type SQ-V1	74	81	87	94
T type SQ-V2	74	81	88	95
T type SQ-V3	70	77	84	91
T type SK-M1-V1	74	81	87	94
T type SK-M1-V2	74	81	88	95
T type SK-MM1-VV1	74	81	87	94
T type SK-MM2-VV1	70	77	84	90
T type SK-MM2-VV2	70	77	84	91

Table 21: Allowable shear force  $V_{Rd,red}$  for near-edge installation with  $e_R \geq 30$ mm

H [mm]	180/280
$V_{Rd}$	[kN]
T type SQ-V1	14,2
T type SQ-V2	20,4
T type SQ-V3	28,5
T type SK-M1-V1	14,2
T type SK-M1-V2	20,4
T type SK-MM1-VV1	14,2
T type SK-MM2-VV1	21,3
T type SK-MM2-VV2	28,5

Schöck Isokorb® T/XT types SK/SQ

Near-edge distances and reduced shear resistances T

Annex 17

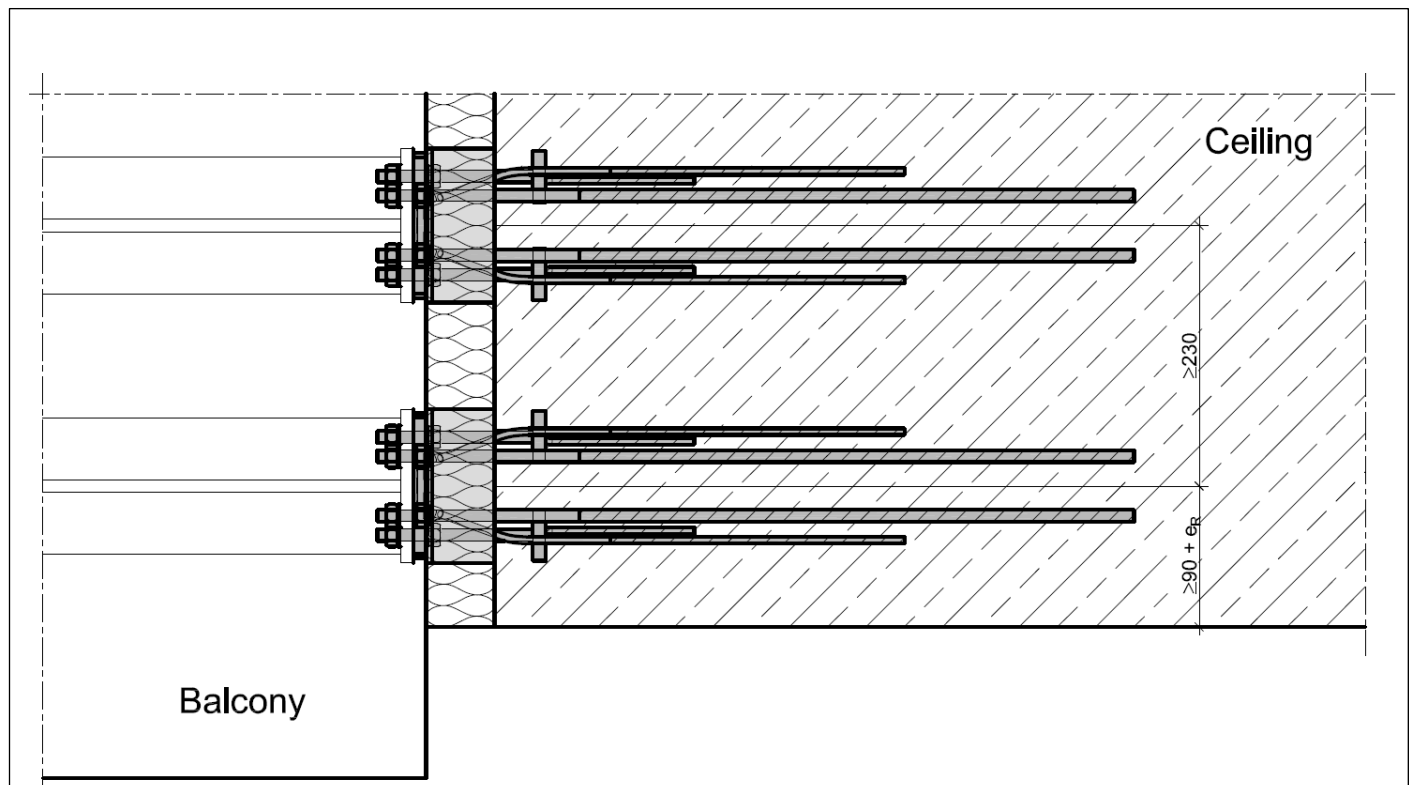

Fig.64 Spacings and edge distances

Table 22: Expected maximum deformations ( $\tan\alpha$ ) resulting from moment loading of the Isokorb at 100% of allowable load for quasi-continuous action combination ( $g=1/3x_p$ ,  $q=2/3x_p$ ,  $\psi_2=0,3$ )

Isokorb type	$Z_{Rd}$	$D_{Rd}$	$\sigma_{Z,Rd}$	$l_z$	$\sigma_{D,Rd}$	$l_D$	H [cm]											
	[kN]	[kN]	[N/mm <sup>2</sup> ]	[mm]	[N/mm <sup>2</sup> ]	[mm]	18	19	20	21	22	23	24	25	26	27	28	
T type SK-M1-V1	89,61	106,50	291	320	346	130	0,3	0,3	0,2	0,2	0,2	0,2	0,2	0,2	0,2	0,2	0,2	0,2
T type SK-M1-V2	78,33	106,50	254	320	346	130	0,3	0,2	0,2	0,2	0,2	0,2	0,2	0,2	0,2	0,1	0,1	0,1
T type SK-MM1-VV1	91,15	108,10	296	320	351	320	0,4	0,4	0,4	0,3	0,3	0,3	0,3	0,3	0,3	0,2	0,2	0,2
T type SK-MM2-VV1	204,90	233,10	326	380	371	380	0,6	0,5	0,5	0,4	0,4	0,4	0,4	0,3	0,3	0,3	0,3	0,3
T type SK-MM2-VV2	190,80	233,10	304	380	371	380	0,5	0,5	0,5	0,4	0,4	0,4	0,3	0,3	0,3	0,3	0,3	0,3

Table 23: Permissible expansion joints

Thickness of insulation joint [mm]	Bar diameter [mm]	
	≤ 14 (M16)	20 (M22)
80,0	5,70m	3,50m

Schöck Isokorb® T/XT types SK/SQ

Angle of twist and design details T

Annex 18

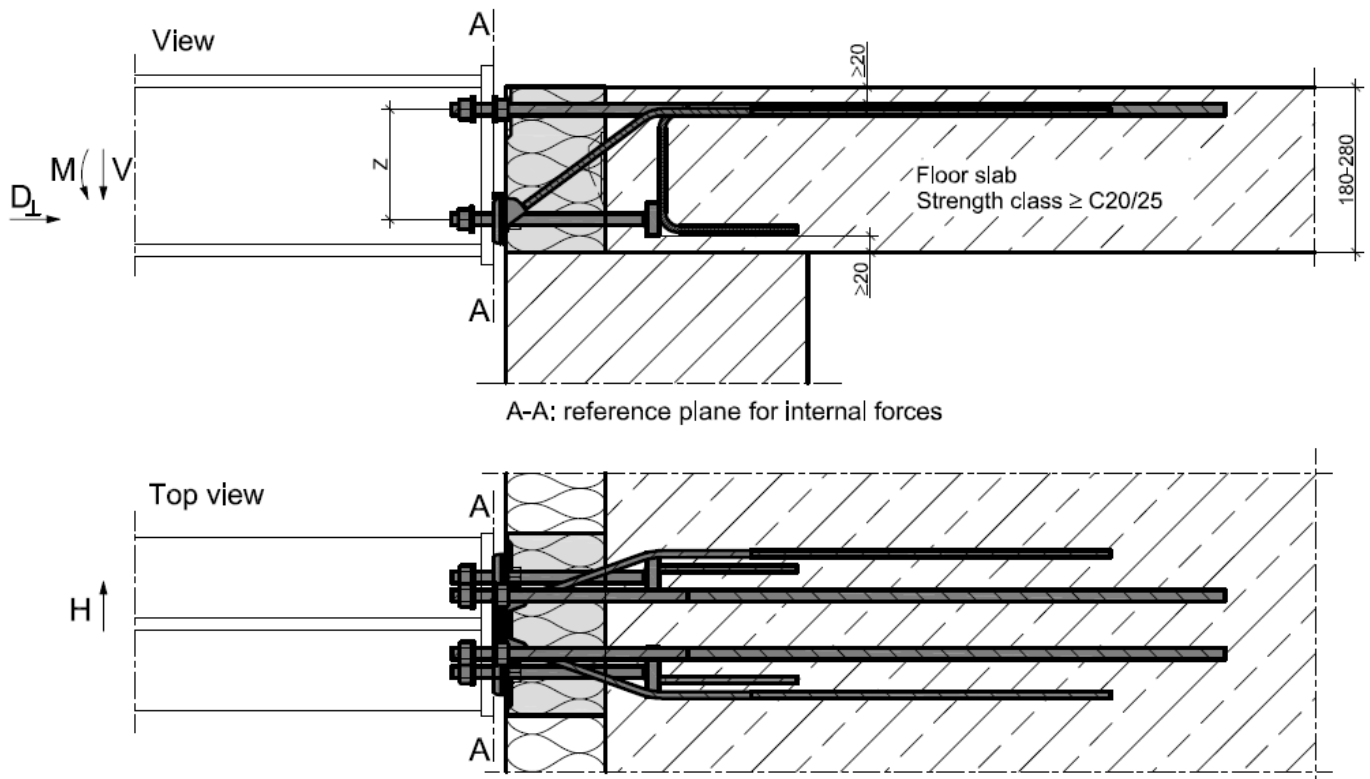

Fig.65 and 66: Schöck Isokorb® XT type SK-M1-V1, definition of internal forces

Schöck Isokorb® T/XT types SK/SQ

Design internal forces for XT type SK-M1-V1

Annex 19  
 Page 1/2

Table 24: Design internal forces for XT type SK-M1-V1

XT type SK-M1-V1			Load case: positive shear forces			
M <sub>Rd</sub> [kNm] for			C20/25		C25/30	
h	z	H <sub>Rd</sub> [kN]	selected V <sub>Ed</sub> [kN]	V <sub>Rd</sub> [kN]	selected V <sub>Ed</sub> [kN]	V <sub>Rd</sub> [kN]
[mm]	[mm]		≤ 6,7	25,1	≤ 6,0	25,1
180	113	± 2,5	11,03	8,23	12,94	10,04
190	123		12,00	8,96	14,09	10,93
200	133		12,98	9,69	15,23	11,82
210	143		13,96	10,42	16,38	12,71
220	153		14,93	11,15	17,52	13,60
230	163		15,91	11,88	18,67	14,49
240	173		16,88	12,61	19,81	15,37
250	183		17,86	13,33	20,96	16,26
260	193		18,84	14,06	22,10	17,15
270	203		19,81	14,79	23,25	18,04
280	213		20,79	15,52	24,39	18,93

M<sub>Rd</sub> may be interpolated for selected  $V_{Ed} \leq V_{Ed} \leq V_{Rd}$

1) For horizontal forces of  $H_{Ed} > 0,488 \times \min. V_{Ed}$  the transmission of the loads between the on-site front plate and the compression bars shall be ensured. For this, round holes can be arranged in the front plate or the screws can be appropriately preloaded.

Table 25: Design internal forces D<sub>⊥</sub> XT type SK-M1-V1 (max. horizontal force perpendicular to insulation joint)

h	C20/25	C25/30
	Load case: positive shear forces	Load case: positive shear forces
	D <sub>Rd⊥</sub>	D <sub>Rd⊥</sub>
[mm]	[kN]	[kN]
180-280	106,5	122,5

For horizontally acting forces D<sub>Ed⊥</sub> perpendicular to the insulation joint, the bending moments M<sub>Rd</sub> shall be determined in accordance with Annex 25.

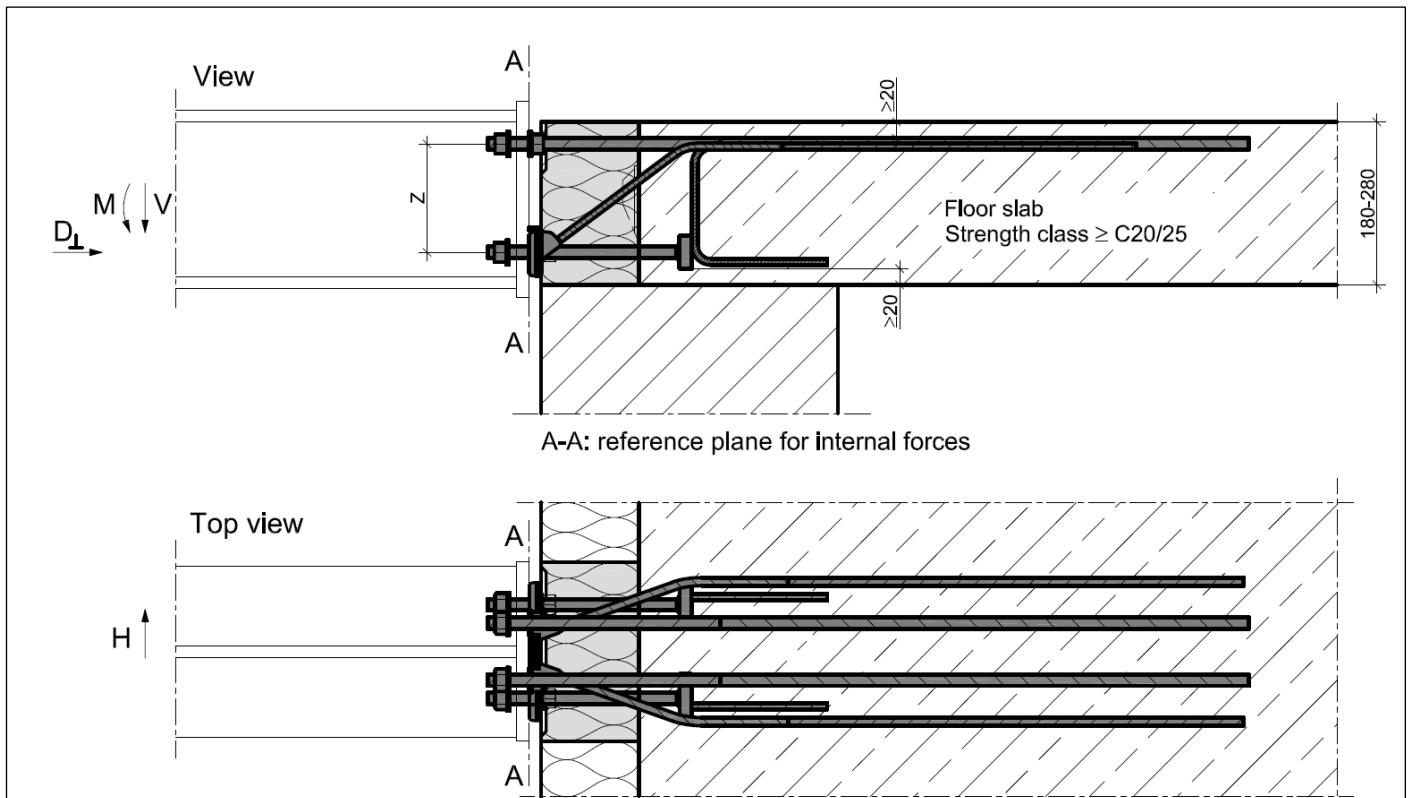

Fig.67 and 68: Schöck Isokorb® XT type SK-M1-V2, definition of internal forces

Schöck Isokorb® T/XT types SK/SQ

Design internal forces XT type SK-M1-V2

Anlage 20  
 Page 1/2

Table 26: Design internal forces for XT type SK-M1-V2

XT type SK-M1-V2			Load case: positive shear forces			
M <sub>Rd</sub> [kNm] for			C20/25		C25/30	
h	z	H <sub>Rd</sub> [kN]	selected V <sub>Ed</sub> [kN]	V <sub>Rd</sub> [kN]	selected V <sub>Ed</sub> [kN]	V <sub>Rd</sub> [kN]
[mm]	[mm]		≤ 8,2	39,20	≤ 8,2	39,20
180	113	± 4,0	10,80	6,09	12,60	7,91
190	123		11,75	6,63	13,72	8,61
200	133		12,71	7,17	14,83	9,31
210	143		13,66	7,71	15,95	10,01
220	153		14,62	8,25	17,06	10,71
230	163		15,57	8,79	18,18	11,40
240	173		16,53	9,33	19,29	12,10
250	183		17,48	9,87	20,41	12,80
260	193		18,44	10,41	21,53	13,50
270	203		19,39	10,95	22,64	14,20
280	213		20,35	11,49	23,76	14,90

M<sub>Rd</sub> may be interpolated for selected V<sub>Ed</sub> ≤ V<sub>Ed</sub> ≤ V<sub>Rd</sub>

1) For horizontal forces of H<sub>Ed</sub> > 0,488 x min. V<sub>Ed</sub> the transmission of the loads between the on-site front plate and the compression bars shall be ensured. For this, round holes can be arranged in the front plate or the screws can be appropriately preloaded.

Table 27: Design internal forces D<sub>⊥</sub> for XT type SK-M1-V2 (max. horizontal force perpendicular to insulation joint)

h	C20/25	C25/30
	Load case: positive shear forces	Load case: positive shear forces
	D <sub>Rd</sub> ⊥	D <sub>Rd</sub> ⊥
[mm]	[kN]	[kN]
180-280	106,5	122,5

For horizontally acting forces D<sub>Ed</sub> ⊥ perpendicular to the insulation joint, the bending moments M<sub>Rd</sub> shall be determined in accordance with Annex 25.

Schöck Isokorb® T/XT types SK/SQ

Design internal forces XT type SK-M1-V2

Annex 20  
 Page 2/2



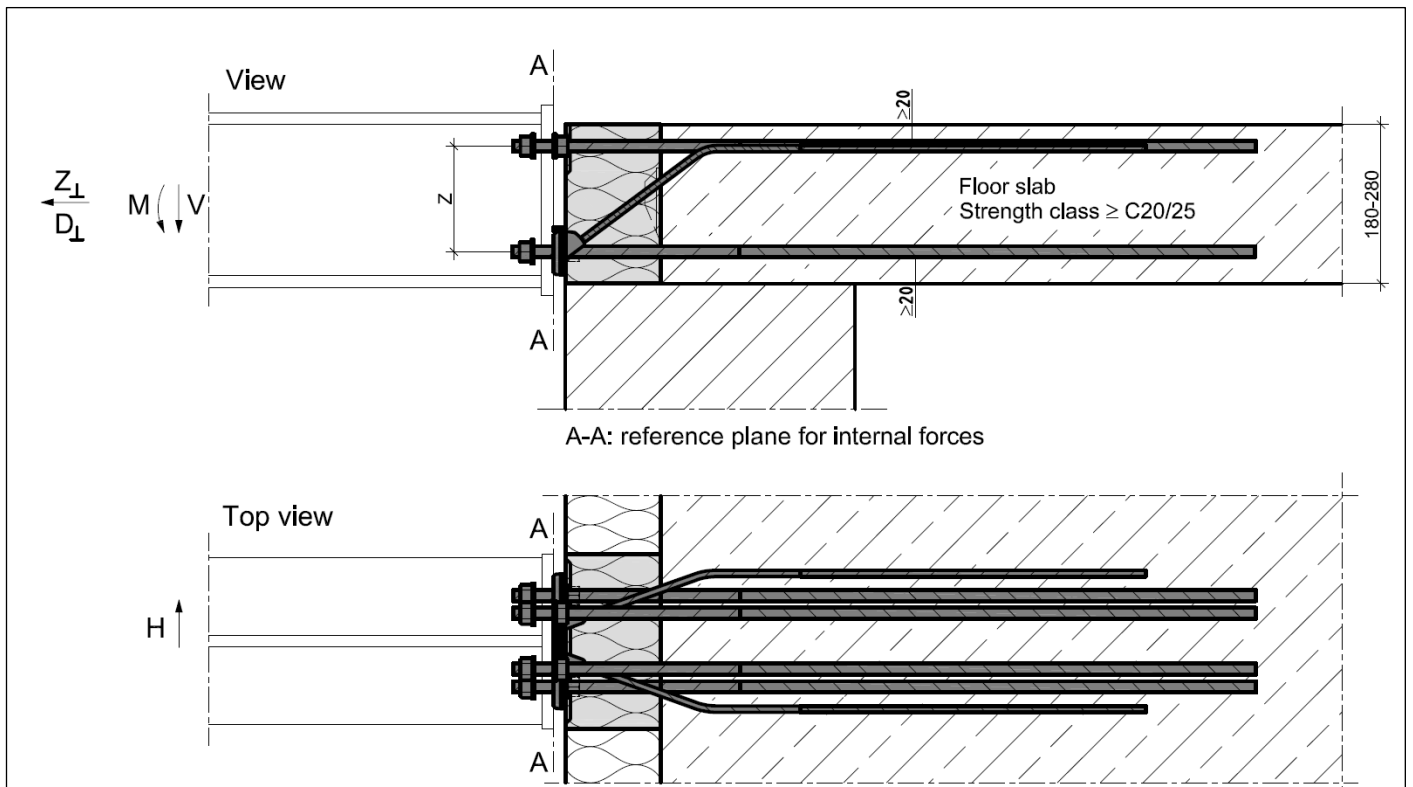

Fig.69 and 70: Schöck Isokorb® XT type SK-MM1-VV1, definition of internal forces

Schöck Isokorb® T/XT types SK/SQ

Design internal forces XT type SK-MM1-VV1

Annex 21  
 Page 1/2

Table 28: Design internal forces for XT type SK-MM1-VV1

XT type SK-MM1-VV1			Load case: negative (uplifting) shear forces	Load case: positive shear forces		Load case: negative (uplifting) shear forces	Load case: positive shear forces	
M <sub>Rd</sub> [kNm] for			C20/25	C20/25		C25/30	C25/30	
h	z	H <sub>Rd</sub> [kN]	V <sub>Rd</sub> [kN]	selected V <sub>Ed</sub> [kN]	V <sub>Rd</sub> [kN]	V <sub>Rd</sub> [kN]	selected V <sub>Ed</sub> [kN]	V <sub>Rd</sub> [kN]
[mm]	[mm]		-12,0	≤ 18,6	25,1	-12,0	≤ 6,0	25,1
180	113	± 2,5	-9,21	11,03	10,04	-11,12	12,94	10,04
190	123		-10,02	12,00	10,93	-12,11	14,09	10,93
200	133		-10,84	12,98	11,82	-13,09	15,23	11,82
210	143		-11,84	13,96	12,71	-14,07	16,38	12,71
220	153		-12,47	14,93	13,60	-15,06	17,52	13,60
230	163		-13,28	15,91	14,49	-16,04	18,67	14,49
240	173		-14,10	16,88	15,37	-17,03	19,81	15,37
250	183		-14,91	17,86	16,26	-18,01	20,96	16,26
260	193		-15,73	18,84	17,15	-19,00	22,10	17,15
270	203		-16,54	19,81	18,04	-19,98	23,25	18,04
280	213		-17,36	20,79	18,93	-20,96	24,39	18,93

M<sub>Rd</sub> may be interpolated for selected  $V_{Ed} \leq V_{Ed} \leq V_{Rd}$

1) For negative shear forces and horizontal forces of  $H_{Ed} > 0,488 \times \min. V_{Ed}$  the transmission of the loads between the on-site front plate and the compression bars shall be ensured. For this, round holes can be arranged in the front plate or the screws can be appropriately preloaded.

Table 29: Design internal forces  $Z_{\perp}$  and  $D_{\perp}$  for XT type SK-MM1-VV1 (max. horizontal force perpendicular to insulation joint)

h	C20/25		C25/30	
	Load case: negative (uplifting) shear force	Load case: positive shear force	Lastfall abhebende Querkräfte	Lastfall positive Querkräfte
	Z <sub>Rd1⊥</sub> or D <sub>Rd,1⊥</sub>	Z <sub>Rd2⊥</sub> or D <sub>Rd,2⊥</sub>	Z <sub>Rd1⊥</sub> or D <sub>Rd,1⊥</sub>	Z <sub>Rd2⊥</sub> or D <sub>Rd,2⊥</sub>
[mm]	[kN]	[kN]	[kN]	[kN]
180-280	±122,5	±122,5	±122,5	±122,5

For horizontally acting forces  $D_{Ed\perp}$  perpendicular to the insulation joint the bending moments  $M_{Rd}$  shall be determined in accordance with Annex 25.

Schöck Isokorb® T/XT types SK/SQ

Design internal forces XT type SK-MM1-VV1

Annex 21  
Page 2/2

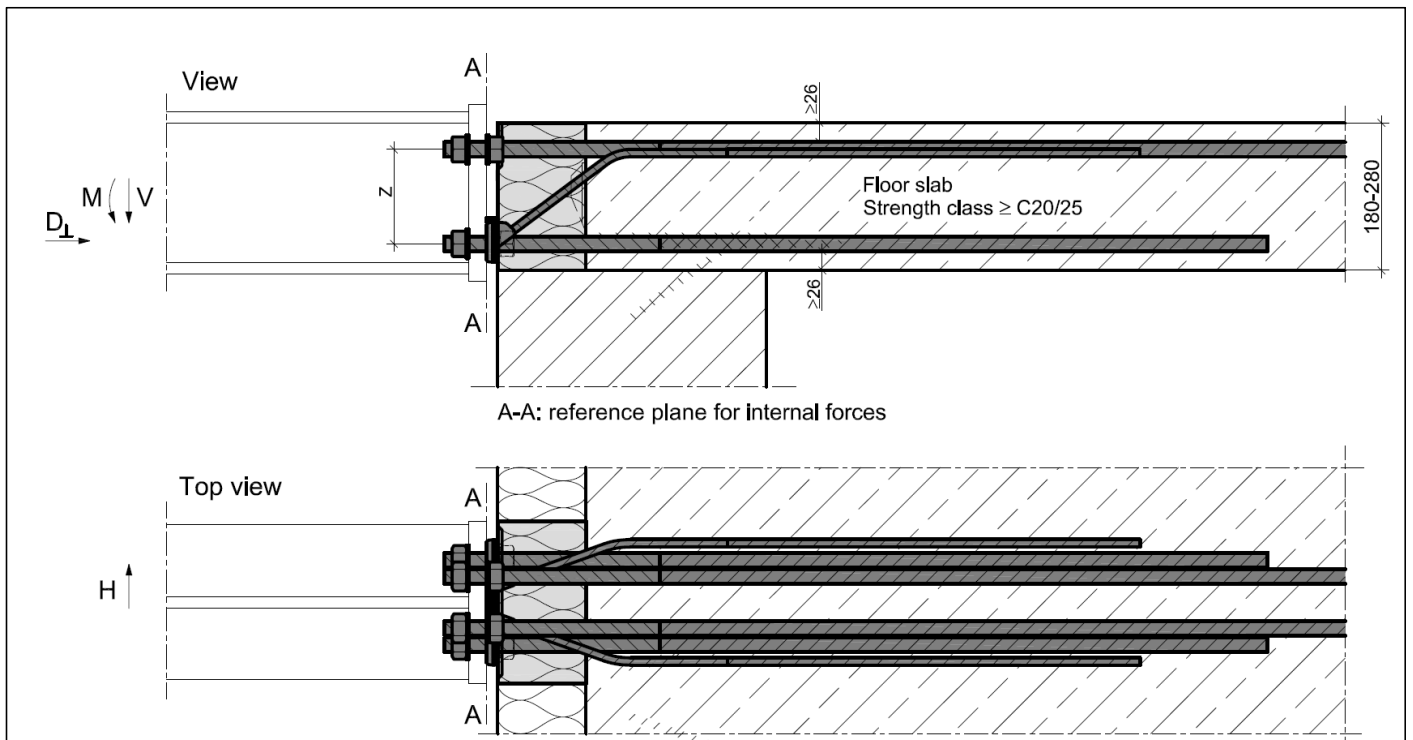

Fig.71 and 72: Schöck Isokorb® XT type SK-MM2-VV1, definition of internal forces

Schöck Isokorb® T/XT types SK/SQ

Design internal forces XT type SK-MM2-VV1

Annex 22  
 Page 1/2

Table 30: Design internal forces for XT type SK-MM2-VV1

XT type SK-MM2-VV1			Load case: negative (uplifting) shear forces	Load case: positive shear forces		Load case: negative (uplifting) shear forces	Load case: positive shear forces	
M <sub>Rd</sub> [kNm] for			C20/25	C20/25		C25/30	C25/30	
h	Z	H <sub>Rd</sub> [kN]	V <sub>Rd</sub> [kN]	selected V <sub>Ed</sub> [kN]	V <sub>Rd</sub> [kN]	V <sub>Rd</sub> [kN]	selected V <sub>Ed</sub> [kN]	V <sub>Rd</sub> [kN]
[mm]	[mm]		-12,0	≤ 21,5	39,2	-12,0	≤ 14,0	39,2
180	108	± 4,0	-11,15	22,66	20,11	-13,39	24,29	22,96
190	118		-12,19	24,76	21,97	-14,63	26,54	25,08
200	128		-13,22	26,86	23,83	-15,87	28,79	27,21
210	138		-14,25	28,96	25,69	-17,11	31,03	29,33
220	148		-15,28	31,06	27,55	-18,35	33,28	31,46
230	158		-16,32	33,16	29,41	-19,59	35,53	33,58
240	168		-17,35	35,26	31,28	-20,83	37,78	35,71
250	178		-18,38	37,35	33,14	-22,07	40,03	37,83
260	188		-19,42	39,45	35,00	-23,31	42,28	39,96
270	198		-20,45	41,55	36,86	-24,55	44,53	42,09
280	208		-21,48	43,65	38,72	-25,79	46,78	44,21

M<sub>Rd</sub> may be interpolated for selected V<sub>Ed</sub> ≤ V<sub>Ed</sub> ≤ V<sub>Rd</sub>

1) For negative shear forces and horizontal forces H<sub>Ed</sub> > 0,488 x min. V<sub>Ed</sub> the transmission of the loads between the on-site front plate and the compression bars shall be ensured. For this, round holes can be arranged in the front plate or the screws can be appropriately preloaded.

Table 31: Design internal forces Z<sub>⊥</sub> and D<sub>⊥</sub> for XT type SK-MM2-VV1  
(max. horizontal force perpendicular to insulation joint)

h	C20/25		C25/30	
	Load case: negative (uplifting) shear forces	Load case: positive shear forces	Load case: negative (uplifting) shear forces	Load case: positive shear forces
	Z <sub>Rd1⊥</sub> or D <sub>Rd1⊥</sub>	Z <sub>Rd2⊥</sub> or D <sub>Rd2⊥</sub>	Z <sub>Rd1⊥</sub> or D <sub>Rd1⊥</sub>	Z <sub>Rd2⊥</sub> or D <sub>Rd2⊥</sub>
[mm]	[kN]	[kN]	[kN]	[kN]
180-280	±238,8	±238,8	±265,2	±265,2

For horizontally acting forces D<sub>Ed⊥</sub> perpendicular to the insulation joint the bending moments M<sub>Rd</sub> shall be determined in accordance with Annex 25.

Schöck Isokorb® T/XT types SK/SQ

Design internal forces XT type SK-MM2-VV1

Annex 22  
Page 2/2

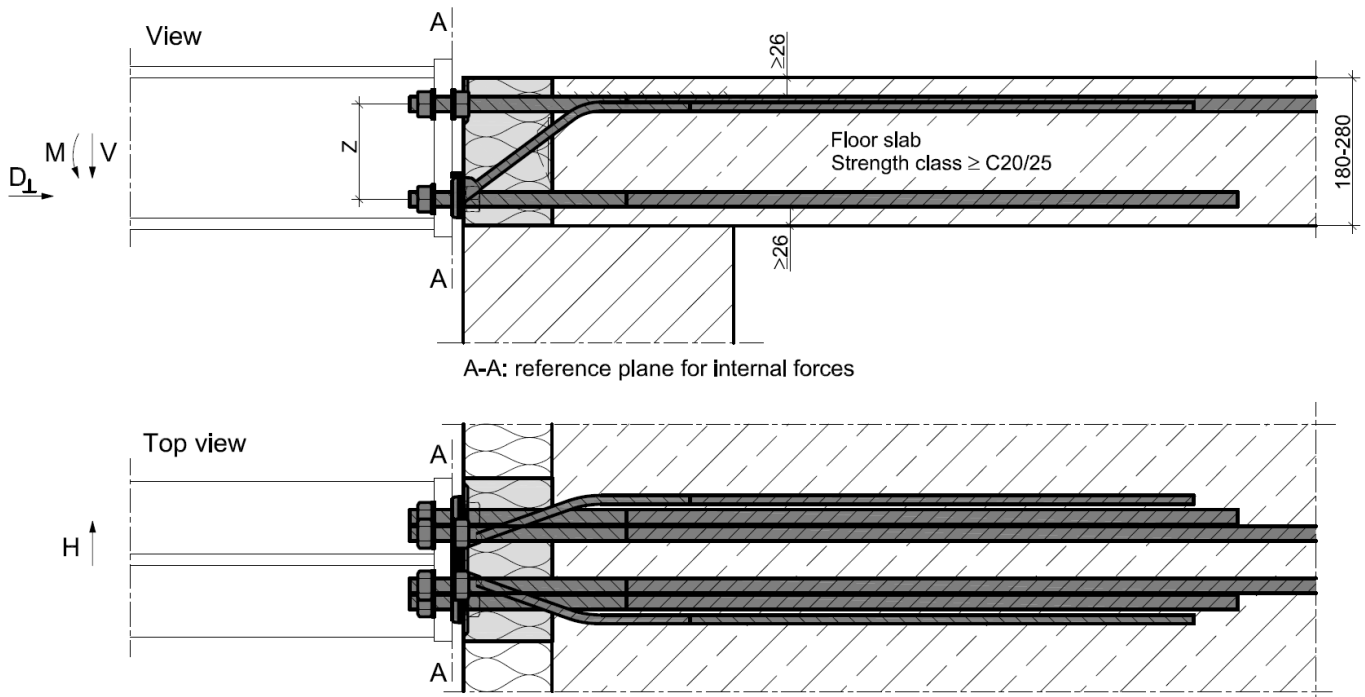

Fig.73 and 74: Schöck Isokorb® XT type SK-MM2-VV2, definition of internal forces

Schöck Isokorb® T/XT types SK/SQ

Design internal forces XT type SK-MM2-VV2

Annex 23  
 Page 1/2

Table 32: Design internal forces for XT type SK-MM2-VV2

XT type SK-MM2-VV2			Load case: negative (uplifting) shear forces	Load case: positive shear forces	Load case: negative (uplifting) shear forces	Load case: positive shear forces		
M <sub>Rd</sub> [kNm] for			C20/25	C20/25	C25/30	C25/30		
h	z	H <sub>Rd</sub> [kN]	V <sub>Rd</sub> [kN]	selected V <sub>Ed</sub> [kN]	V <sub>Rd</sub> [kN]	V <sub>Rd</sub> [kN]	selected V <sub>Ed</sub> [kN]	V <sub>Rd</sub> [kN]
[mm]	[mm]		-12,0	≤ 21,5	56,4	-12,0	≤ 14	56,4
180	108	± 6,5	-10,95	22,66	17,61	-13,19	26,60	20,46
190	118		-11,96	24,76	19,24	-14,41	29,06	22,35
200	128		-12,97	26,86	20,87	-15,63	31,53	24,24
210	138		-13,99	28,96	22,50	-16,85	33,99	26,14
220	148		-15,00	31,06	24,13	-18,07	36,45	28,03
230	158		-16,02	33,16	25,76	-19,29	38,92	29,93
240	168		-17,03	35,26	27,39	-20,51	41,38	31,82
250	178		-18,04	37,35	29,02	-21,73	43,84	33,72
260	188		-19,06	39,45	30,65	-22,95	46,30	35,61
270	198		-20,07	41,55	32,28	-24,18	48,77	37,50
280	208		-21,08	43,65	33,91	-25,40	51,23	39,40

M<sub>Rd</sub> may be interpolated for selected  $V_{Ed} \leq V_{Ed} \leq V_{Rd}$

1) For negative shear forces and horizontal forces of  $H_{Ed} > 0,488 \times \min. V_{Ed}$  the transmission of the loads between the on-site front plate and the compression bars shall be ensured. For this, round holes can be arranged in the front plate or the screws can be appropriately preloaded.

Table 33: Design internal forces  $Z_{\perp}$  and  $D_{\perp}$  for XT type SK-MM2-VV2  
(max. horizontal force perpendicular to insulation joint)

h	C20/25		C25/30	
	Load case: negative (uplifting) shear forces	Load case: positive shear forces	Load case: negative (uplifting) shear forces	Load case: positive shear forces
	Z <sub>Rd1⊥</sub> or D <sub>Rd,1⊥</sub>	Z <sub>Rd2⊥</sub> or D <sub>Rd,2⊥</sub>	Z <sub>Rd1⊥</sub> or D <sub>Rd,1⊥</sub>	Z <sub>Rd2⊥</sub> or D <sub>Rd,2⊥</sub>
[mm]	[kN]	[kN]	[kN]	[kN]
180-280	±238,8	±238,8	±265,2	±265,2

For horizontally acting forces  $D_{Ed\perp}$  perpendicular to the insulation joint, the bending moments  $M_{Rd}$  shall be determined in accordance with Annex 25.

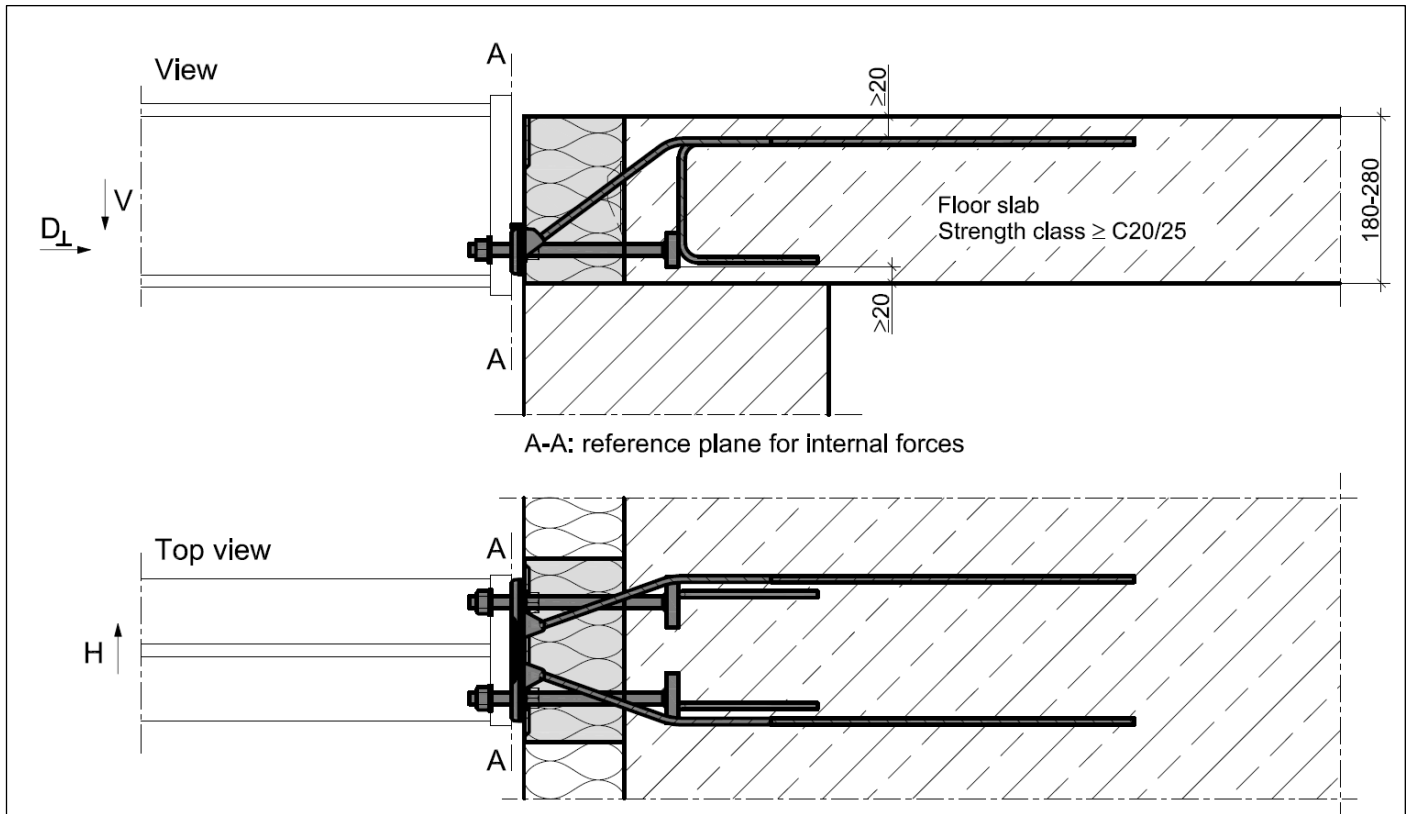

Fig.75 and 76: Schöck Isokorb® XT types SQ-V1, SQ-V2 and SQ-V3, definition of internal forces

Schöck Isokorb® T/XT types SK/SQ

Design internal forces for XT types SQ-V1, SQ-V2, SQ-V3

Annex 24  
 Page 1/2

Table 34: Design internal forces for XT type SQ-V1, SQ-V2 and SQ-V3

Load case: positive shear forces C20/25 + C25/30	XT type SQ-V1			XT type SQ-V2			XT type SQ-V3			
	h [mm]	H <sub>Rd</sub> [kN]	V <sub>Rd</sub> [kN]	D <sub>Rd</sub> ⊥ [kN]	H <sub>Rd</sub> [kN]	V <sub>Rd</sub> [kN]	D <sub>Rd</sub> ⊥ [kN]	H <sub>Rd</sub> [kN]	V <sub>Rd</sub> [kN]	D <sub>Rd</sub> ⊥ [kN]
180										
190										
200			C20/25 106,5			C20/25 106,5				C20/25 106,5
210										
220										
230		± 4,0		± 4,0	39,17		± 6,5	56,41		
240			C25/30 122,5			C25/30 122,5				C25/30 122,5
250										
260										
270										
280										

1) For horizontal forces of  $H_{Ed} > 0,488 \times \min. V_{Ed}$  the transmission of the loads between the on-site front plate and the compression bars shall be ensured. For this, round holes can be arranged in the front plate or the screws can be appropriately preloaded.

2) The horizontally acting forces  $D_{Ed\perp}$  perpendicular to the insulation joint are determined as follows:

For the compression forces  $D_{\perp}$ :  $D_{ED \perp} \leq D_{RD \perp} - \cos 20^\circ \times \cos 35^\circ / \sin 35^\circ \times V_{Ed} - \cos 20^\circ / \sin 20^\circ \cdot |H_{Ed}|$

For the tensile forces  $Z_{\perp}$ :  $Z_{ED \perp} \leq \cos 20^\circ / \tan 35^\circ \times \min |V_{Ed}| / 1,1$

Schöck Isokorb® T/XT types SK/SQ

Design internal forces for XT types SQ-V1, SQ-V2, SQ-V3

Annex 24  
 Page 2/2



Table 35: Moments  $M_{Rd\perp}$  for horizontal forces ( $D_{Rd\perp}$  and  $Z_{Rd\perp}$ ) perpendicular to the insulation joint for positive shear forces and C20/25

Isokorb type	$M_{Rd\perp}$ for perpendicular compression [kNm]	$M_{Rd\perp}$ for perpendicular tension [kNm]
XT type SK-MM1-V1 XT type SK-MM1-V2	$M_{Rd\perp} = \min. \left[ \begin{array}{l} 97,6 \times z/1000 \\ (106,5 - D_{Ed\perp} \downarrow/2 - \cos 20^\circ \times \cos 35^\circ / \sin 35^\circ \times \text{selected } V_{Ed}) \times z/1000 \end{array} \right]$	
XT type SK-MM1-VV1	$M_{Rd\perp} = \min. \left[ \begin{array}{l} 97,6 \times z/1000 \\ (122,5 - D_{Ed\perp} \downarrow/2 - \cos 20^\circ \times \cos 35^\circ / \sin 35^\circ \times \text{selected } V_{Ed}) \times z/1000 \end{array} \right]$	$M_{Rd\perp} = \min. \left[ \begin{array}{l} (97,6 - Z_{Ed\perp} \downarrow/2) \times z/1000 \\ (122,5 - D_{Ed\perp} \downarrow/2 - \cos 20^\circ \times \cos 35^\circ / \sin 35^\circ \times \text{selected } V_{Ed}) \times z/1000 \end{array} \right]$
XT type SK-MM2-VV1 XT type SK-MM2-VV2	$M_{Rd\perp} = \min. \left[ \begin{array}{l} 209,9 \times z/1000 \\ (238,8 - D_{Ed\perp} \downarrow/2 - \cos 20^\circ \times \cos 35^\circ / \sin 35^\circ \times \text{selected } V_{Ed}) \times z/1000 \end{array} \right]$	$M_{Rd\perp} = \min. \left[ \begin{array}{l} (209,9 - Z_{Ed\perp} \downarrow/2) \times z/1000 \\ (238,8 - \cos 20^\circ \times \cos 35^\circ / \sin 35^\circ \times \text{selected } V_{Ed}) \times z/1000 \end{array} \right]$

Table 36: Moments  $M_{Rd\perp}$  for horizontal forces ( $D_{Rd\perp}$  and  $Z_{Rd\perp}$ ) perpendicular to the insulation joint for negative shear forces (load case: uplift) and C20/25

Isokorb type	$M_{Rd\perp}$ for perpendicular compression [kNm]	$M_{Rd\perp}$ for perpendicular tension [kNm]
XT type SK-MM1-VV1	$M_{Rd\perp} = \min. \left[ \begin{array}{l} -1 \times (122,5 - D_{Ed\perp} \downarrow/2) \times z/1000 \\ -1 \times (97,6 - \cos 20^\circ \times \cos 35^\circ / \sin 35^\circ \times \text{selected }  V_{Ed} ) \times z/1000 \end{array} \right]$	$M_{Rd\perp} = \min. \left[ \begin{array}{l} -1 \times 122,5 \times z/1000 \\ -1 \times (97,6 - Z_{Ed\perp} \downarrow/2 - \cos 20^\circ \times \cos 35^\circ / \sin 35^\circ \times \text{selected }  V_{Ed} ) \times z/1000 \end{array} \right]$
XT type SK-MM2-VV1 XT type SK-MM2-VV2	$M_{Rd\perp} = \min. \left[ \begin{array}{l} -1 \times (265,2 - D_{Ed\perp} \downarrow/2) \times z/1000 \\ -1 \times (119,4 - \cos 20^\circ \times \cos 35^\circ / \sin 35^\circ \times \text{selected }  V_{Ed} ) \times z/1000 \end{array} \right]$	$M_{Rd\perp} = \min. \left[ \begin{array}{l} -1 \times 265,2 \times z/1000 \\ -1 \times (119,4 - Z_{Ed\perp} \downarrow/2 - \cos 20^\circ \times \cos 35^\circ / \sin 35^\circ \times \text{selected }  V_{Ed} ) \times z/1000 \end{array} \right]$

Schöck Isokorb® T/XT types SK/SQ

Moments for horizontal loads perpendicular to joint XT

Annex 25  
 Page 1/2

Table 37: Moments  $M_{Res, \perp}$  for horizontal forces ( $D_{Ed, \perp}$  and  $Z_{Ed, \perp}$ ) perpendicular to the insulation joint for positive shear forces and C25/30

Isokorb type	$M_{Res, \perp}$ for perpendicular compression [kNm]	$M_{Res, \perp}$ for perpendicular tension [kNm]
XT type SK-M1-V1 XT type SK-M1-V2	$M_{Res, \perp} = \min. \left[ \begin{array}{l} 114,5 \times z/1000 \\ (122,5 - D_{Ed, \perp} / 2 - \cos 20^\circ \times \cos 35^\circ / \sin 35^\circ \times \text{selected } V_{Ed}) \times z/1000 \end{array} \right.$	$M_{Res, \perp} = \min. \left[ \begin{array}{l} (114,5 - Z_{Ed, \perp} / 2) \times z/1000 \\ (122,5 - D_{Ed, \perp} / 2 - \cos 20^\circ \times \cos 35^\circ / \sin 35^\circ \times \text{selected } V_{Ed}) \times z/1000 \end{array} \right.$
XT type SK-MM1-VV1	$M_{Res, \perp} = \min. \left[ \begin{array}{l} 114,5 \times z/1000 \\ (122,5 - D_{Ed, \perp} / 2 - \cos 20^\circ \times \cos 35^\circ / \sin 35^\circ \times \text{selected } V_{Ed}) \times z/1000 \end{array} \right.$	$M_{Res, \perp} = \min. \left[ \begin{array}{l} (114,5 - Z_{Ed, \perp} / 2) \times z/1000 \\ (122,5 - D_{Ed, \perp} / 2 - \cos 20^\circ \times \cos 35^\circ / \sin 35^\circ \times \text{selected } V_{Ed}) \times z/1000 \end{array} \right.$
XT type SK-MM2-VV1 XT type SK-MM2-VV2	$M_{Res, \perp} = \min. \left[ \begin{array}{l} 246,3 \times z/1000 \\ (265,2 - D_{Ed, \perp} / 2 - \cos 20^\circ \times \cos 35^\circ / \sin 35^\circ \times \text{selected } V_{Ed}) \times z/1000 \end{array} \right.$	$M_{Res, \perp} = \min. \left[ \begin{array}{l} (246,3 - Z_{Ed, \perp} / 2) \times z/1000 \\ (265,2 - \cos 20^\circ \times \cos 35^\circ / \sin 35^\circ \times \text{selected } V_{Ed}) \times z/1000 \end{array} \right.$

Table 38: Moments  $M_{Res, \perp}$  for horizontal forces ( $D_{Ed, \perp}$  and  $Z_{Ed, \perp}$ ) perpendicular to the insulation joint for negative shear forces (load case: uplift) and C25/30

Isokorb type	$M_{Res, \perp}$ for perpendicular compression [kNm]	$M_{Res, \perp}$ for perpendicular tension [kNm]
XT type SK-MM1-VV1	$M_{Res, \perp} = \min. \left[ \begin{array}{l} -1 \times (122,5 - D_{Ed, \perp} / 2) \times z/1000 \\ -1 \times (114,5 - \cos 20^\circ \times \cos 35^\circ / \sin 35^\circ \times \text{selected }  V_{Ed} ) \times z/1000 \end{array} \right.$	$M_{Res, \perp} = \min. \left[ \begin{array}{l} -1 \times 122,5 \times z/1000 \\ -1 \times (114,5 - Z_{Ed, \perp} / 2 - \cos 20^\circ \times \cos 35^\circ / \sin 35^\circ \times \text{selected }  V_{Ed} ) \times z/1000 \end{array} \right.$
XT type SK-MM2-VV1 XT type SK-MM2-VV2	$M_{Res, \perp} = \min. \left[ \begin{array}{l} -1 \times (265,2 - D_{Ed, \perp} / 2) \times z/1000 \\ -1 \times (140,1 - \cos 20^\circ \times \cos 35^\circ / \sin 35^\circ \times \text{selected }  V_{Ed} ) \times z/1000 \end{array} \right.$	$M_{Res, \perp} = \min. \left[ \begin{array}{l} -1 \times 265,2 \times z/1000 \\ -1 \times (140,1 - Z_{Ed, \perp} / 2 - \cos 20^\circ \times \cos 35^\circ / \sin 35^\circ \times \text{selected }  V_{Ed} ) \times z/1000 \end{array} \right.$

Schöck Isokorb® T/XT types SK/SQ

Moments for horizontal loads perpendicular to joint XT

Annex 25  
 Page 2/2

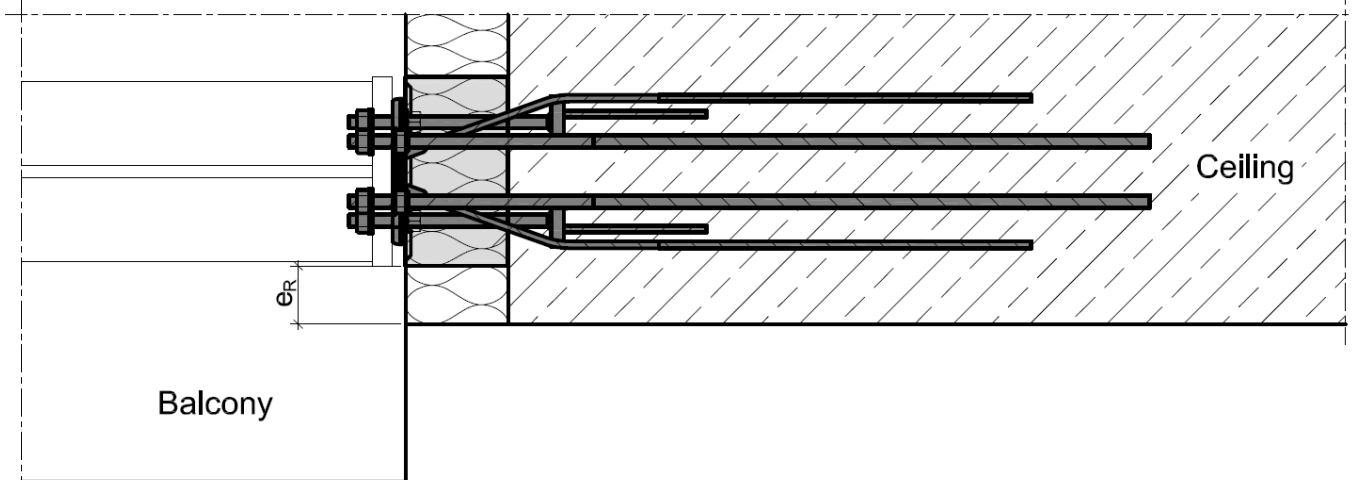

Fig.77 Near-edge installation

Table 39: Edge distances  $e_R$  with classification as 'near-edge'

'Isokorb' height	Near-edge from $e_R$ [mm]			
	180/190	200/210	220/230	240/280
XT type SQ-V1	66	76	85	95
XT type SQ-V2	67	76	86	95
XT type SQ-V3	61	71	80	90
XT type SK-M1-V1	66	76	85	95
XT type SK-M1-V2	67	76	86	95
XT type SK-MM1-VV1	66	76	85	95
XT type SK-MM2-VV1	61	70	80	90
XT type SK-MM2-VV2	61	71	80	90

Table 40: Allowable shear force  $V_{Rd,red}$  for near-edge installation with  $e_R \geq 30\text{mm}$

h [mm]	180/280	
	C20/25	C25/30
$V_{Rd}$	[kN]	[kN]
XT type SQ-V1	11,4	14,4
XT type SQ-V2	16,5	20,7
XT type SQ-V3	23,3	29,3
XT type SK-M1-V1	11,4	14,4
XT type SK-M1-V2	16,5	20,7
XT type SK-MM1-VV1	11,4	14,4
XT type SK-MM2-VV1	17,4	21,8
XT type SK-MM2-VV2	23,3	29,3

Schöck Isokorb® T/XT types SK/SQ

Near-edge distances and reduced shear resistances XT

Annex 26

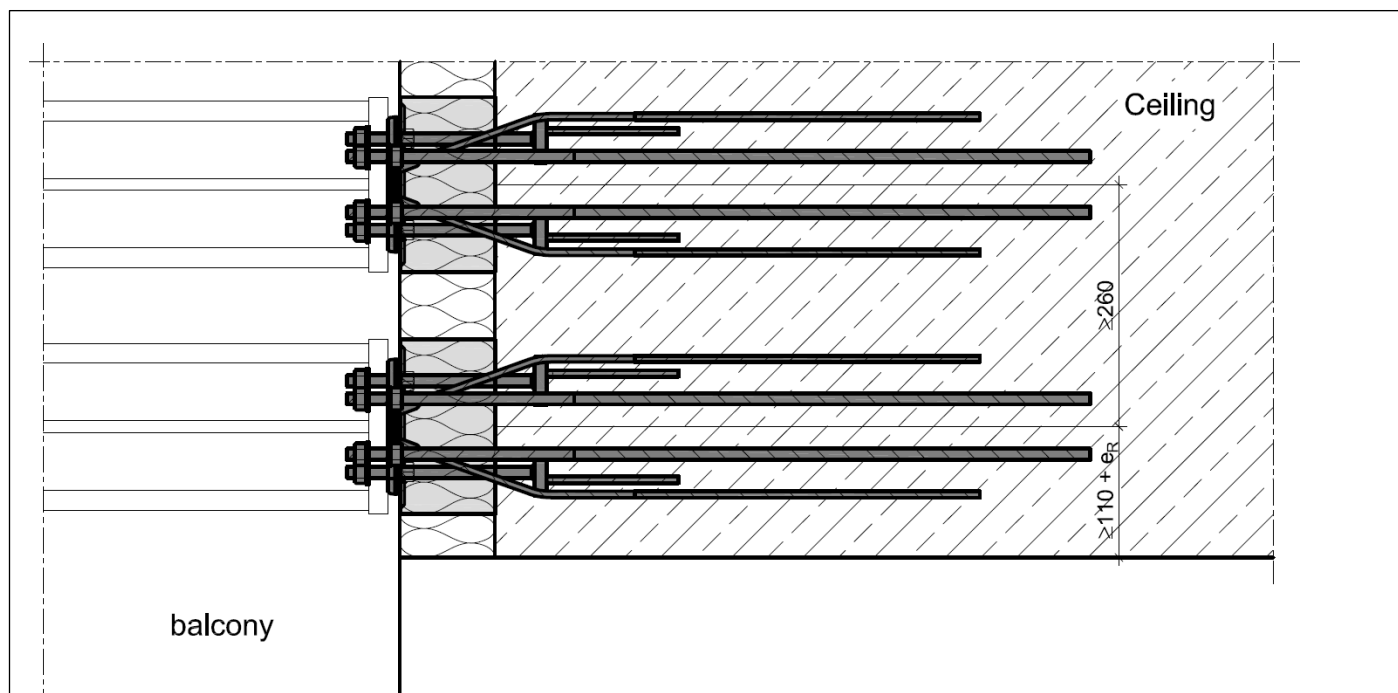

Fig.78 Spacings and edge distances

Table 41: Expected maximum deformations ( $\tan\alpha$ ) resulting from moment loading of the Isokorb at 100% of allowable load for quasi-continuous action combination ( $g=1/3x_p$ ,  $q=2/3x_p$ ,  $\psi_2=0,3$ )

	Isokorb type	$Z_{Rd}$	$D_{Rd}$	$\sigma_{Z,Rd}$	$l_z$	$\sigma_{D,Rd}$	$l_D$	H [cm]											
		[kN]	[kN]	[N/mm <sup>2</sup> ]	[mm]	[N/mm <sup>2</sup> ]	[mm]	18	19	20	21	22	23	24	25	26	27	28	
C20/25	XT type SK-M1-V1	97,6	106,5	117	460	127	170	0,4	0,4	0,3	0,3	0,3	0,3	0,3	0,3	0,2	0,2	0,2	0,2
	XT type SK-M1-V2	97,6	106,5	117	460	127	170	0,4	0,4	0,3	0,3	0,3	0,3	0,3	0,2	0,2	0,2	0,2	
	XT type SK-MM1-VV1	97,6	122,5	117	460	146	430	0,6	0,5	0,5	0,5	0,4	0,4	0,4	0,4	0,3	0,3	0,3	
	XT type SK-MM2-VV1	209,9	238,8	123	550	140	520	0,7	0,7	0,6	0,6	0,5	0,5	0,5	0,4	0,4	0,4	0,4	
	XT type SK-MM2-VV2	209,9	238,8	123	550	140	520	0,7	0,7	0,6	0,6	0,5	0,5	0,5	0,4	0,4	0,4	0,4	
C25/30	XT type SK-M1-V1	114,5	122,5	137	460	146	170	0,5	0,4	0,4	0,4	0,3	0,3	0,3	0,3	0,3	0,3	0,2	
	XT type SK-M1-V2	114,5	122,5	137	460	146	170	0,5	0,4	0,4	0,4	0,3	0,3	0,3	0,3	0,3	0,3	0,2	
	XT type SK-MM1-VV1	114,5	122,5	137	460	146	430	0,6	0,6	0,5	0,5	0,5	0,4	0,4	0,4	0,4	0,4	0,3	
	XT type SK-MM2-VV1	246,3	265,2	144	550	155	520	0,8	0,8	0,7	0,6	0,6	0,6	0,5	0,5	0,5	0,4	0,4	
	XT type SK-MM2-VV2	246,3	265,2	144	550	155	520	0,8	0,8	0,7	0,6	0,6	0,6	0,5	0,5	0,5	0,4	0,4	

Table 42: Permissible expansion joints

Thickness of insulation joint [mm]	Bar diameter [mm]	
	≤ 14 (M16)	20 (M22)
120	8,60m	5,30m

Schöck Isokorb® T/XT types SK/SQ

Angle of twist and design details XT

Annex 27

An on-site cleat (flat steel  $h=40\text{mm}$ ,  $t=15\text{mm}$ ), welded to the head plate, is mandatorily required for safe transmission of the shear force to Schöck Isokorb® T type SK, XT type SK, T type SQ or XT type SQ!

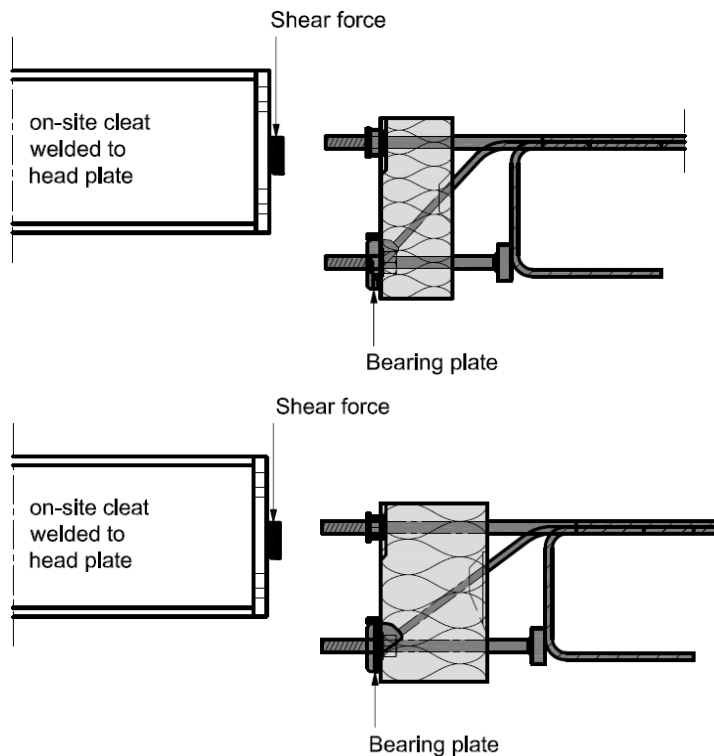

Fig.79 Shear force transmission through cleat

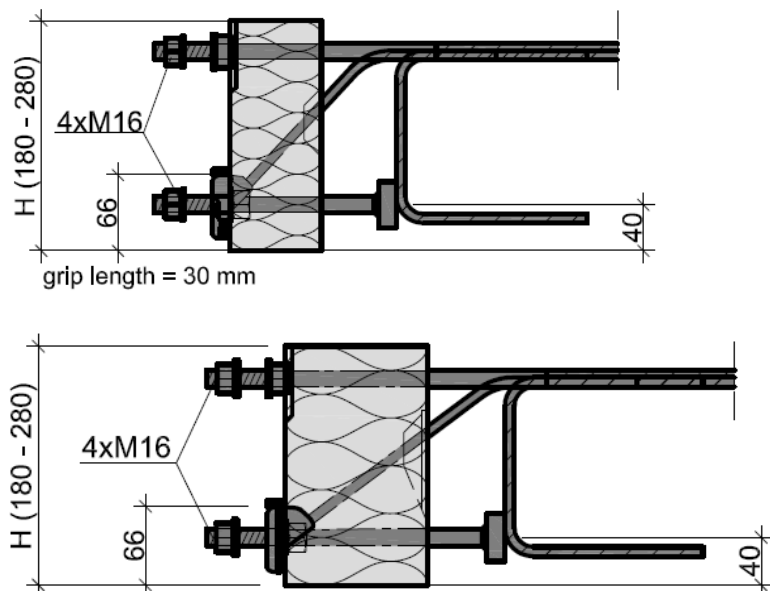

Fig.80 Side view: Schöck Isokorb® T types SK-M1-V1, SK-M1-V2 and XT types SK-M1-V1 and SK-M1-V2

Schöck Isokorb® T/XT types SK/SQ

Connection details for steel structure – T/XT types M1-V1, M1-V2 and MM1-VV1

Annex 28  
 Page 1/2

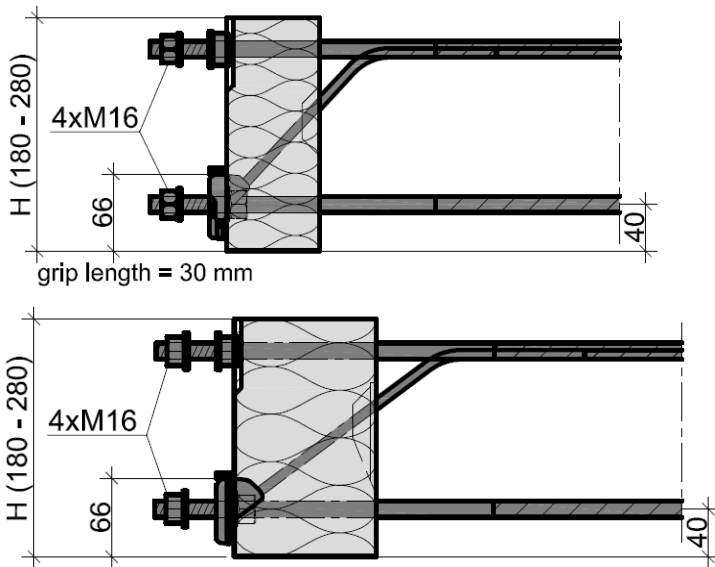
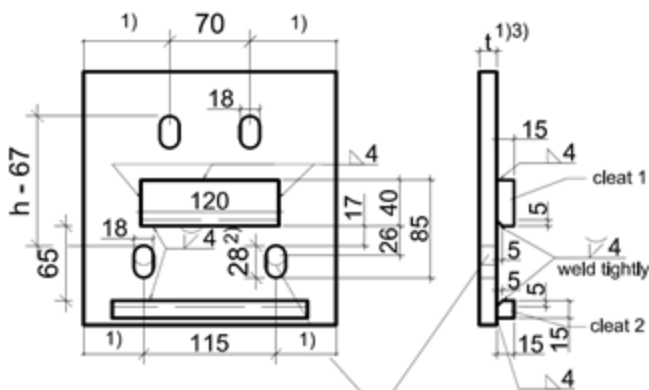

Fig.81 Side view: Schöck Isokorb® T type SK-MM1-VV1 and XT type SK-MM1-VV1



Load case negative (uplifting) shear forces: round holes  
 Alternative: cleat 2  
 Please note: only applies to T type SK-MM1-VV1 and  
 XT type SK-MM1-VV1

Steel grade in accordance with structural requirements.  
 Provide corrosion protection after welding.

- <sup>1)</sup> in accordance with information supplied by structural engineer.
- <sup>2)</sup> Hole dimension corresponds to height adjustment of +10mm.  
 Height adjustment can be increased through an increase in hole dimension.
- <sup>3)</sup> Observe grip length.

Fig.82 On-site front plate for Schöck Isokorb® T types SK-M1-V1, SK-M1-V2 and SK-MM1-VV1 as well as XT types SK-M1-V1, SK-M1-V2 and SK-MM1-VV1

Schöck Isokorb® T/XT types SK/SQ

Connection details for steel structure – T/XT types M1-V1, M1-V2 and MM1-VV1

Annex 28  
 Page 2/2



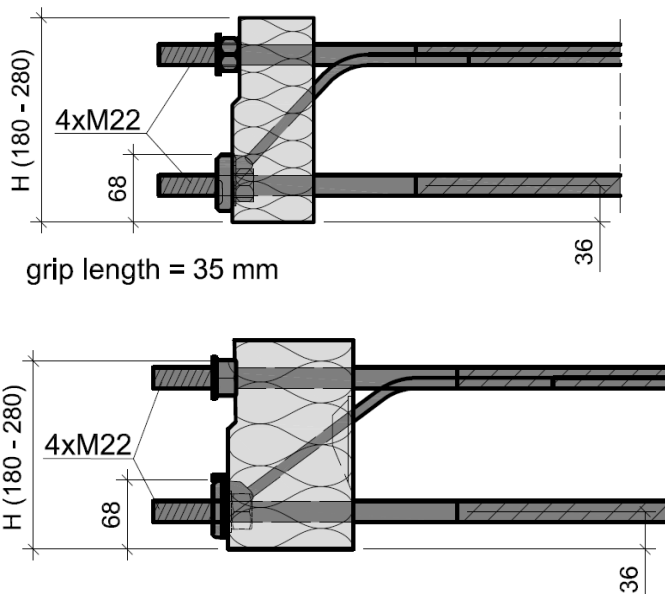
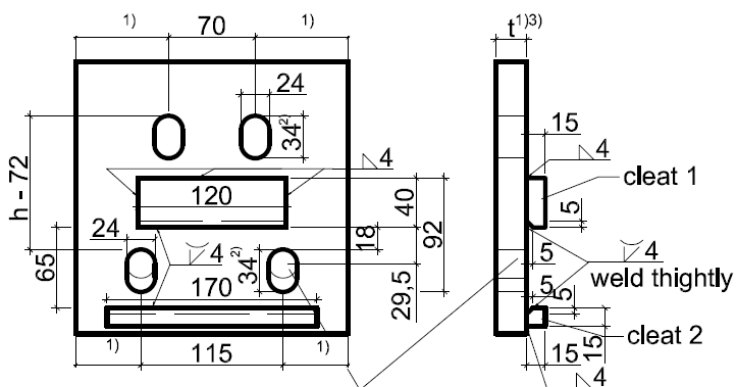

Fig.83 Side view: Schöck Isokorb® T types SK-MM2-VV1, SK-MM2-VV2 and XT types SK-MM2-VV1, SK-MM2-VV2



Load case negative (uplifting) shear forces: round holes  
 Alternative: cleat 2

Fig.84 On-site front plate for Schöck Isokorb® T types SK-MM2-VV1, SK-MM2-VV2 and XT types SK-MM2-VV1, SK-MM2-VV2

Schöck Isokorb® T/XT types SK/SQ

Connection details for steel structure – T/XT types MM2-VV1, MM2-VV2 as well as SQ-V1, SQ-V2 and SQ-V3

Annex 29  
 Page 1/2

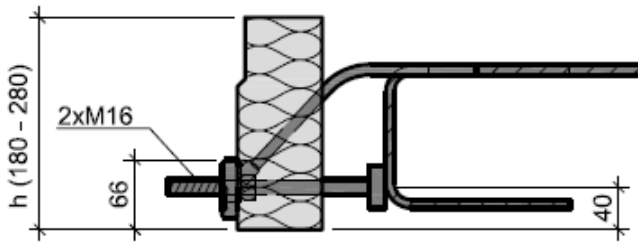

grip length = 30 mm

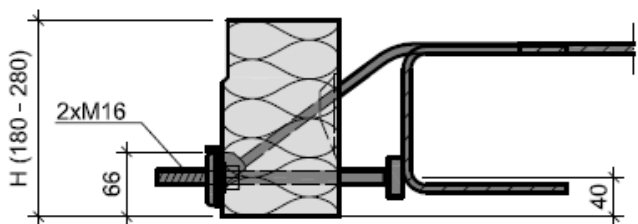

grip length = 30 mm

Fig.85 Side view: Schöck Isokorb® T types SQ-V1, SQ-V2, SQ-V3 and XT types SQ-V1, SQ-V2, SQ-V3

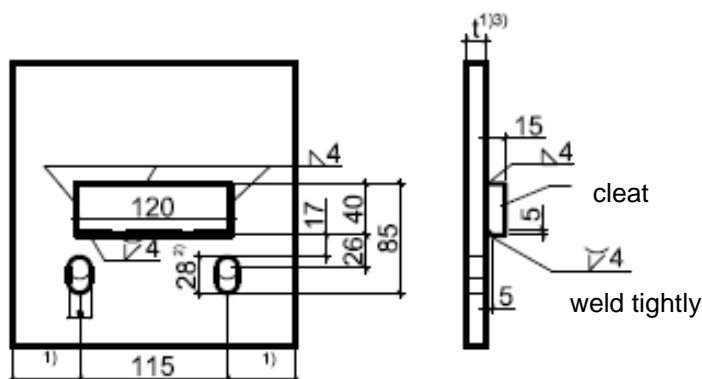

Fig.86 On-site front plate for Schöck Isokorb® T types SQ-V1, SQ-V2, SQ-V3 and XT types SQ-V1, SQ-V2, SQ-V3

Schöck Isokorb® T/XT types SK/SQ

Connection details for steel structure – T/XT types MM2-VV1, MM2-VV2 as well as SQ-V1, SQ-V2 and SQ-V3

Annex 29  
 Page 2/2



Schöck Isokorb® T type SK-M1-V1 and SK-M1-V2

Lap joint: connection 2 Ø 14 mm, design in accordance with DIN EN 1992-1-1, Pos. 1

Transverse reinforcement: structural transverse reinforcement in accordance with DIN EN 1992-1-1,  
 structural edge stirrup reinforcement, 2 Ø 8 mm. Pos. 2

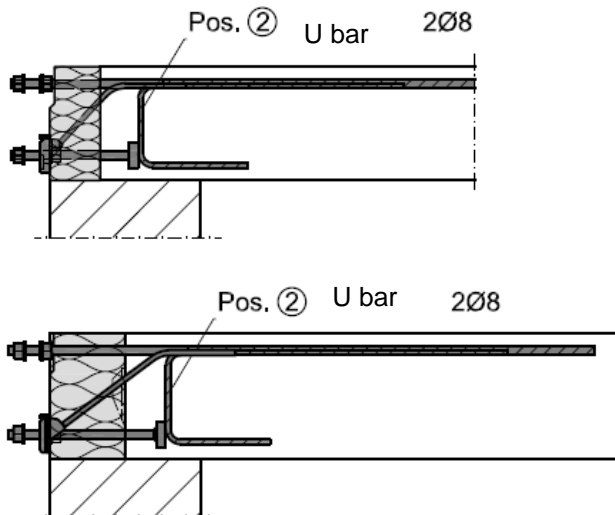

Fig.87 Side view: Schöck Isokorb® T types SK-M1-V1, SK-M1-V2 and  
 XT types SK-M1-V1, SK-M1-V2

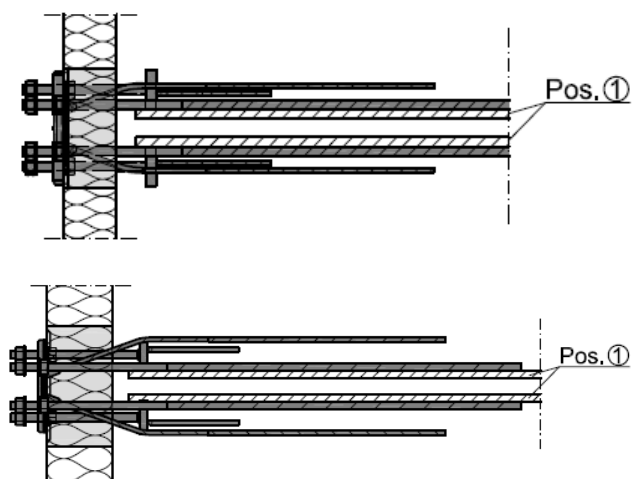

Fig.88 Top view: Schöck Isokorb® T type SK-M1-V1, T type SK-M1-V2 and  
 XT type SK-M1-V1, XT type SK-M1-V2

Schöck Isokorb® T/XT types SK/SQ

Design details for T/XT types M1-V1, M1-V2 and MM1-VV1

Annex 30  
 Page 1/2

Schöck Isokorb® T type SK-MM1-VV1

Lap joint: connection 2 Ø 14 mm, design in accordance with DIN EN 1992-1-1, Pos. 1

Transverse reinforcement: structural transverse reinforcement in accordance with DIN EN 1992-1-1

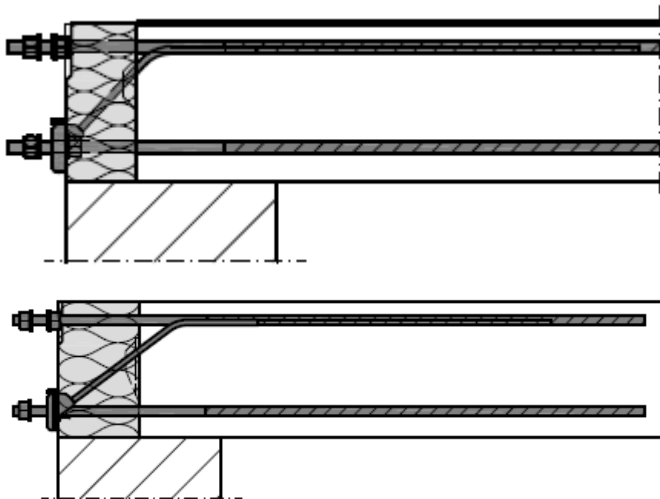

Fig.89 Side view: Schöck Isokorb® T type SK-MM1-VV1 and XT type SK-MM1-VV1

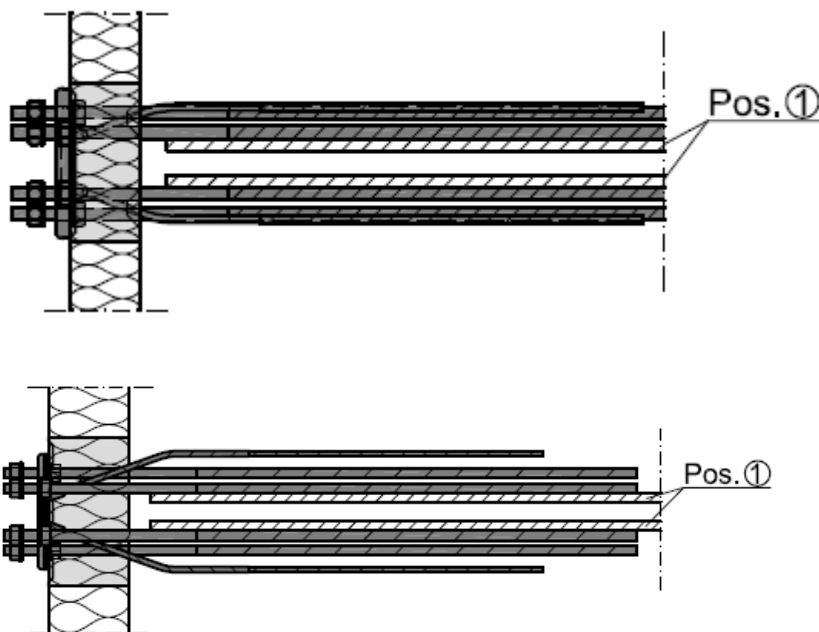

Fig.90 Top view: Schöck Isokorb® T type SK-MM1-VV1 and XT type SK-MM1-VV1

Schöck Isokorb® T/XT types SK/SQ

Design details for T/XT types M1-V1, M1-V2 and MM1-VV1

Annex 30  
 Page 2/2

Schöck Isokorb® T types SK-MM2-VV1 and SK-MM2-VV2

Lap joint: connection 4 Ø 14 mm, design in accordance with DIN EN 1992-1-1, Pos. 4

Transverse reinforcement: exterior transverse reinforcement in the form of stirrups (see figure), Pos. 5

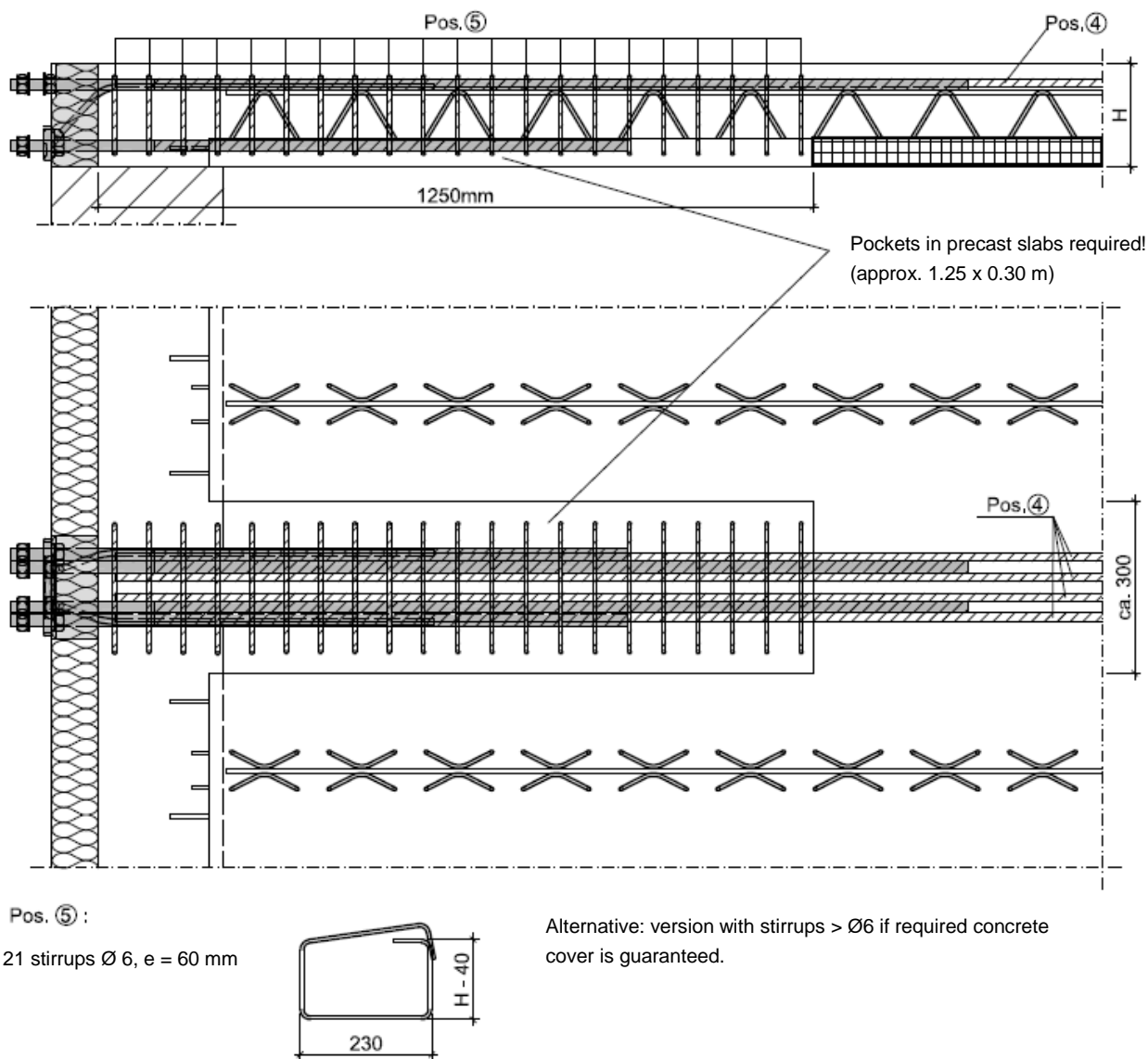

Fig.91 On-site connection reinforcement for Schöck Isokorb® T types SK-MM2-VV1 and SK-MM2-VV2

Schöck Isokorb® T/XT types SK/SQ

Design details for T types MM2-VV1 and MM2-VV2

Annex 31

Schöck Isokorb® XT types SK-MM2-VV1 and SK-MM2-VV2

Lap joint: connection 4 Ø 14 mm, design in accordance with DIN EN 1992-1-1, Pos. 4

Transverse reinforcement: exterior transverse reinforcement in the form of stirrups (see figure), Pos. 5

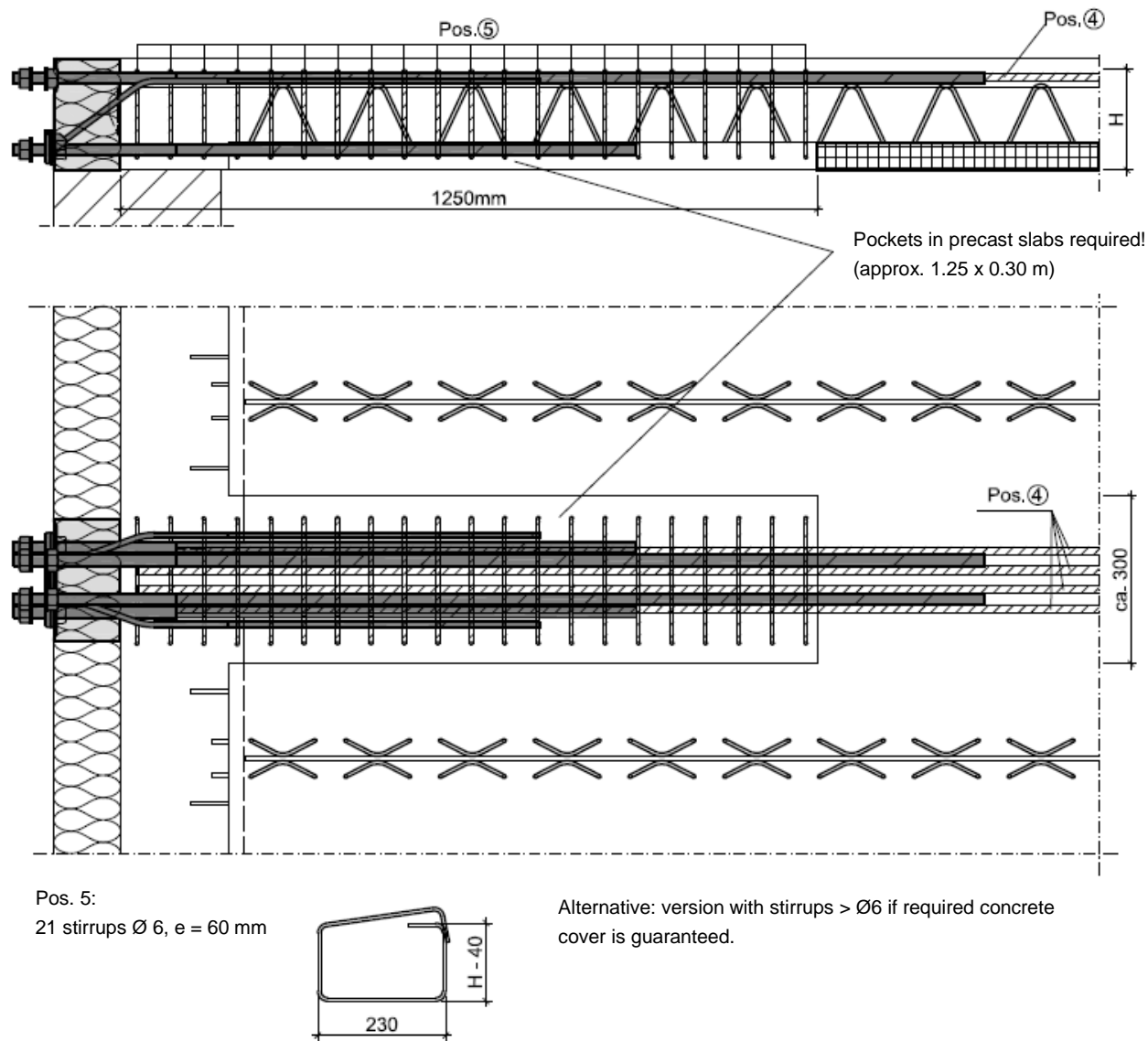
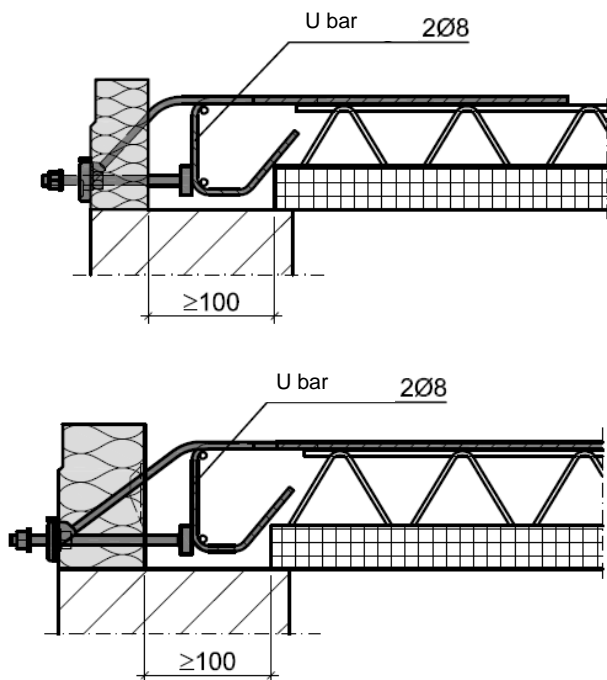

Fig.92 On-site reinforcement for Schöck Isokorb® XT types SK-MM2-VV1 and SK-MM2-VV2

Schöck Isokorb® types T/XT SK/SQ

Design details for XT types MM2-VV1 and MM2-VV2

Annex 32



An additional connection reinforcement due to Schöck Isokorb® T/XT type SQ is not necessary.

Fig. 93 On-site connection reinforcement for Schöck Isokorb® T/XT type SQ with bent-up U bar.

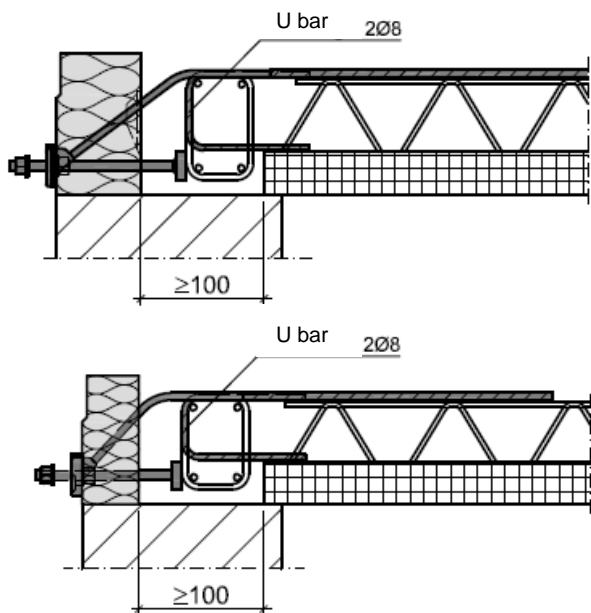

An additional connection reinforcement due to Schöck Isokorb® T/XT type SQ is not necessary.

Fig. 94 On-site connection reinforcement for Schöck Isokorb® T/XT type SQ with U bar and additional stirrup

**Schöck Isokorb® T/XT types SK/SQ**

**Design details with precast floor slabs for T/XT types SQ-V1, SQ-V2, SQ-V3**

**Annex 33**